

**Technical
Information**



MOTOROLA W24 DEVELOPER'S GUIDE

DEVELOPER'S KIT



ENGLISH
MARCH 31, 2008
6802985C05-A

SPECIFICATIONS SUBJECT TO CHANGE WITHOUT NOTICE

Notice

While reasonable efforts have been made to assure the accuracy of this document, Motorola, Inc. assumes no liability resulting from any inaccuracies or omissions in this document, or from use of the information obtained herein. The information in this document has been carefully checked and is believed to be entirely reliable. However, no responsibility is assumed for inaccuracies or omissions. Motorola, Inc. reserves the right to make changes to any products described herein and reserves the right to revise this document and to make changes from time to time in content hereof with no obligation to notify any person of revisions or changes. Motorola, Inc. does not assume any liability arising out of the application or use of any product, software, or circuit described herein; neither does it convey license under its patent rights or the rights of others.

It is possible that this publication may contain references to, or information about Motorola products (machines and programs), programming, or services that are not announced in your country. Such references or information must not be construed to mean that Motorola intends to announce such Motorola products, programming, or services in your country.

Copyrights

This instruction manual, and the Motorola products described in this instruction manual may be, include or describe copyrighted Motorola material, such as computer programs stored in semiconductor memories or other media. Laws in the United States and other countries preserve for Motorola and its licensors certain exclusive rights for copyrighted material, including the exclusive right to copy, reproduce in any form, distribute and make derivative works of the copyrighted material. Accordingly, any copyrighted material of Motorola and its licensors contained herein or in the Motorola products described in this instruction manual may not be copied, reproduced, distributed, merged or modified in any manner without the express written permission of Motorola. Furthermore, the purchase of Motorola products shall not be deemed to grant either directly or by implication, estoppel, or otherwise, any license under the copyrights, patents or patent applications of Motorola, as arises by operation of law in the sale of a product.

Computer Software Copyrights

The Motorola and 3rd Party supplied Software (SW) products described in this instruction manual may include copyrighted Motorola and other 3rd Party supplied computer programs stored in semiconductor memories or other media. Laws in the United States and other countries preserve for Motorola and other 3rd Party supplied SW certain exclusive rights for copyrighted computer programs, including the exclusive right to copy or reproduce in any form the copyrighted computer program. Accordingly, any copyrighted Motorola or other 3rd Party supplied SW computer programs contained in the Motorola products described in this instruction manual may not be copied (reverse engineered) or reproduced in any manner without the express written permission of Motorola or the 3rd Party SW supplier. Furthermore, the purchase of Motorola products shall not be deemed to grant either directly or by implication, estoppel, or otherwise, any license under the copyrights, patents or patent applications of Motorola or other 3rd Party supplied SW, except for the normal non-exclusive, royalty free license to use that arises by operation of law in the sale of a product.

VENDOR COPYRIGHT

Apache Software Foundation Copyright 2004-2005 All Rights Reserved

Usage and Disclosure Restrictions

License Agreements

The software described in this document is the property of Motorola, Inc. and its licensors. It is furnished by express license agreement only and may be used only in accordance with the terms of such an agreement.

Copyrighted Materials

Software and documentation are copyrighted materials. Making unauthorized copies is prohibited by law. No part of the software or documentation may be reproduced, transmitted, transcribed, stored in a retrieval system, or translated into any language or computer language, in any form or by any means, without prior written permission of Motorola, Inc.

High Risk Materials

Components, units, or third-party products used in the product described herein are NOT fault-tolerant and are NOT designed, manufactured, or intended for use as on-line control equipment in the following hazardous environments requiring fail-safe controls: the operation of Nuclear Facilities, Aircraft Navigation or Aircraft Communication Systems, Air Traffic Control, Life Support, or Weapons Systems (High Risk Activities"). Motorola and its supplier(s) specifically disclaim any expressed or implied warranty of fitness for such High Risk Activities.

Trademarks



MOTOROLA and the Stylized M Logo are registered in the US Patent & Trademark Office. All other product or service names are the property of their respective owners.

© Copyright 2008 Motorola, Inc.

REV052604



Table of Contents

Manual Scope	vii
Target Audience	vii
Manual Organization	vii
Applicable Documents	vii
Developer Board Safety	viii
Contact Us	viii
Text Conventions	ix
Field Service	ix
General Safety	ix
Caring for the Environment	xi
Limitation of Liability	xi
Warranty Notification	xii
How to Get Warranty Service?	xiii
Claiming	xiii
Conditions	xiii
What is Not Covered by the Warranty	xiv
Installed Data	xiv
Out of Warranty Repairs	xv
Revision History	xvi
Chapter 1: Introduction	1
General Description	1
Package Contents	3
Chapter 2: Developer Board and Interfaces Description	5
Overview	5
Developer Board Features and Structure	5
Initial Setup	7
Connecting the W24	7
Connecting External Accessories	9
Power Supply	9
Serial Communications	10
Audio Devices	10
SIM Card	10
Antenna	10
Power Up	11
Configuration	12
Alternate Power Sources	12
Wall Mount Adapter Operation	13
DC Power Source Operation	13
Selecting the Power Source	15
Disconnecting Power	15

Communication Interfaces	16
RS232-1	16
RS232-2	17
USB	17
Data Logger	17
Audio Interface	17
Antenna	18
Option Switches	21
Analog to Digital Converter (ADC) - S160, S161	21
General Purpose I/O (GPIO) - S120	21
UID - S170	22
General Function Switch - S140	22
General Function Switch - S141	23
General Function Switch - S100	23
SIM Card	24
Host Connection	25
Components and Specifications	27
Connectors Description	27
W24 Interface Connector	28
Switches and Jumpers	29
LED Indicators	31
Chapter 3: Service and Troubleshooting	33
Service	33
Who to Contact?	33
Required Query Information	33
Motorola Workflow	34
Service Centers	35
Troubleshooting	36
Appendix A: Parts List	A-1
Developer Board Parts list	A-1
Developer Board Unplaced Parts list	A-6
Appendix B: Schematics and Placement Diagrams	B-1
Acronyms and Abbreviations	
Index	

Figure No.	Figure Title	Page No.
1-1	W24 Developer's Kit—Top View with Cover	1
1-2	W24 Developer's Kit—Front View with Cover	2
1-3	W24 Developer's Kit—Left Side View with Cover	2
1-4	W24 Developer's Kit—Rear View with Cover	2
1-5	W24 Developer's Kit—Right Side View with Cover	2
1-6	W24 Developer's Kit with Board, W24 and Accessories	4
2-1	Developer Board Structure	6
2-2	Connecting the W24 (Stand alone configuration)	8
2-3	Connecting the W24 + G24 (Stacked configuration)	9
2-4	Developer Board Power Switch and Adapter Connector (Rear)	10
2-5	W24 On/Off Pushbutton and Power Indicator LED	11
2-6	Power Supply Connectors, Jumpers and Switches	12
2-7	W24 Developer's Kit Wall Mount Adapter Connector	13
2-8	DC Input Connectors	14
2-9	USB, RS232-1, RS232-2 and Data Logger Connectors	16
2-10	Antenna Connectors (external)	18
2-11	Wi-Fi Antenna Connection	19
2-12	Antenna Connectors (internal)	20
2-13	S120 Switches	21
2-14	S170 Switches	22
2-15	S141 Switches	23
2-16	S100 Switches	23
2-17	70-pin Connectors	25
2-18	Jumpers and Switches on Developer Board	29
2-19	LEDs on Developer Board	31

Table No.	Table Title	Page No.
1-1	W24 Developer's Kit Package Contents.	3
2-1	Wall Mount Adapter Connector Pinout (J230).	13
2-2	Power Source Jumpers (P203, P204)	15
2-3	W24 Power Jumpers (P200, P201)	15
2-4	RS232-1 Connector Pinout (J300)	16
2-5	USB Connector Pinout (J380).	17
2-6	GPIO Signals Mapping.	21
2-7	S100 Switches Functionality.	24
2-8	Developer Board Connectors	27
2-9	W24 Connectors Pinout	28
2-10	Developer Board Switches and Jumpers.	30
2-11	Developer Board LED Indicators	32
3-1	Troubleshooting	36
A-1	Developer Board Parts List	A-1
A-2	Developer Board Unplaced Parts List.	A-6

Preface

Manual Scope

This manual introduces the W24 Developer's Kit, and describes the technical details required by the user to successfully integrate the Motorola W24 cellular engine into an original equipment manufacturer (OEM) wireless host device. This Developer's Kit supports two operation configurations: Stand alone configuration (W24 only), and stacked configuration (W24 + G24).

With the help of this manual, the user can utilize the Developer's Kit to conduct a full series of test and evaluation procedures on the W24, as well as perform application development.

Target Audience

This manual is intended for all members of the integration team who are responsible for integrating the W24 into the host application, including representatives from hardware, software and RF engineering disciplines.

Manual Organization

This manual contains the following chapters:

- **Chapter 1**—introduces the W24 Developer's Kit
- **Chapter 2**—describes the Developer Board and its components in detail, including connectors, jumpers, switches and LED indicators. It also includes a set of setup procedures for first-time use
- **Chapter 3**—provides contact information for Motorola Service Support and Customer Assistance
- **Appendix A**—provides a parts list for the W24 Developer's Kit
- **Appendix B**—provides schematics and placement diagrams for the W24 Developer's Kit

Applicable Documents

- W24 Module Hardware Description: 6802984C95
- W24 ATi Commands: 6802985C10

Developer Board Safety

Precautions

Most Developer Board circuits are not shielded. Be sure to take appropriate precautionary measures in order to avoid ESD while handling the kit. ESD can damage the Developer Board and/or the W24 module attached to it.

User Operation

Do not operate your unit when a person is within eight inches (20 centimeters) of the antenna. A person or object within eight inches (20 centimeters) of the antenna could impair call quality and may cause the unit to operate at a higher power level than necessary, as well as expose that person to RF energy in excess of that established by the FCC RF Exposure Guidelines.

Important: The unit must be installed in a manner that provides a minimum separation distance of eight inches (20 centimeters) or more between the antenna and persons and must not be co-located or operate in conjunction with any other antenna or transmitter in order to satisfy FCC RF exposure requirements for mobile transmitting devices.

Important: To comply with the FCC RF exposure limits and to satisfy the categorical exclusion requirements for mobile transmitters, the requirements described in the following section, “[Antenna Installation](#)”, must be met.

Antenna Installation

- A minimum separation distance of eight inches (20 centimeters) must be maintained between the antenna and all persons.
- When a Wi-Fi antenna is used (both configurations), **TBD**
- When a GSM antenna is used (stacked configuration), the combined cable loss and antenna gain must not exceed +7.5 dBi (850 band). The combined cable loss and antenna gain must not exceed +2.5 dBi and total system output must not exceed 2.0W EIRP in the PCS (1900) band in order to comply with the EIRP limit of 24.232 (b). OEM installers must be provided with antenna installation instruction and transmitter operating conditions for satisfying RF exposure compliance.

Contact Us

We at Motorola want to make this guide as helpful as possible. Keep us informed of your comments and suggestions for improvements.

For general contact, technical support, report documentation errors and to order manuals, use this email address:

M2M.CustomerCare@motorola.com

Motorola appreciates feedback from the users of our information.

Text Conventions

The following special paragraphs are used in this guide to point out information that must be read. This information may be set-off from the surrounding text, but is always preceded by a bold title in capital letters:

Note

Note: Presents additional, helpful, noncritical information that you can use.

Warning

Warning: Presents information to warn you of a potentially hazardous situation in which there is a possibility of personal injury.

Important

Important: Presents information to help you avoid an undesirable situation or provides additional information to help you understand a topic or concept.

Caution

Caution: Presents information to identify a situation in which damage to software, stored data, or equipment could occur, thus avoiding the damage.

Field Service

For Field Service requests, use this email address:
M2M.CustomerCare@motorola.com

General Safety

Remember!. . . safety depends on you!

The following general safety precautions must be observed during all phases of operation, service, and repair of the equipment described in this manual. Failure to comply with these precautions or with specific warnings elsewhere in this manual violates safety standards of design, manufacture, and intended use of the equipment. Motorola, Inc. assumes no liability for the customer's failure to comply with these requirements. The safety precautions listed below represent warnings of certain dangers of which we are aware. You, as the user of this product,

should follow these warnings and all other safety precautions necessary for the safe operation of the equipment in your operating environment.

Ground the instrument

To minimize shock hazard, the equipment chassis and enclosure must be connected to an electrical ground. If the equipment is supplied with a three-conductor AC power cable, the power cable must be either plugged into an approved three-contact electrical outlet or used with a three-contact to two-contact adapter. The three-contact to two-contact adapter must have the grounding wire (green) firmly connected to an electrical ground (safety ground) at the power outlet. The power jack and mating plug of the power cable must meet International Electrotechnical Commission (IEC) safety standards.

Note: Refer to *“Grounding Guideline for Cellular Radio Installations”* –Motorola part no. 68P081150E62.

Do not operate in an explosive atmosphere

Do not operate the equipment in the presence of flammable gases or fumes. Operation of any electrical equipment in such an environment constitutes a definite safety hazard.

Do not service or adjust alone

Do not attempt internal service or adjustment unless another person, capable of rendering first aid is present.

Keep away from live circuits

Operating personnel must:

- not remove equipment covers. Only Factory Authorized Service Personnel or other qualified maintenance personnel may remove equipment covers for internal subassembly, or component replacement, or any internal adjustment
- not replace components with power cable connected. Under certain conditions, dangerous voltages may exist even with the power cable removed
- always disconnect power and discharge circuits before touching them

Do not substitute parts or modify equipment

Because of the danger of introducing additional hazards, do not install substitute parts or perform any unauthorized modification of equipment. Contact Motorola Warranty and Repair for service and repair to ensure that safety features are maintained.

Dangerous procedure warnings

Warnings, such as the example below, precede potentially dangerous procedures throughout this manual. Instructions contained in the warnings must be followed. You should also employ all

other safety precautions that you deem necessary for the operation of the equipment in your operating environment.

Warning example:

Warning: Dangerous voltages, capable of causing death, are present in this equipment. Use extreme caution when handling, testing, and adjusting.

Caring for the Environment

The following information is provided to enable regulatory compliance with the European Union (EU) Directive [2002/96/EC Waste Electrical and Electronic Equipment \(WEEE\)](#) when using Motorola equipment in EU countries.

Disposal of Motorola equipment in EU countries



Please do not dispose of Motorola equipment in landfill sites.

In the EU, Motorola in conjunction with a recycling partner will ensure that equipment is collected and recycled according to the requirements of EU environmental law.

Please contact the Customer Network Resolution Center (CNRC) for assistance. The 24 hour telephone numbers are listed at

<http://mynetworksupport.motorola.com>

Select **Customer Network Resolution Center contact information**.

Alternatively if you do not have access to CNRC or the internet, contact the Local Motorola Office.

Disposal of Motorola equipment in non-EU countries

In non-EU countries, dispose of Motorola equipment in accordance with national and regional regulations.

Limitation of Liability

The Products are not designed, intended, or authorized for use as components in systems intended for surgical implant into the body; in other applications intended to support or sustain life; for the planning, construction, maintenance, operation or use of any nuclear facility; for the flight, navigation, communication of aircraft or ground support equipment; or in any other application in which the failure of the Product could create a situation where personal injury or death may occur. If CUSTOMER should use any Product or provide any Product to a third party for any such use, CUSTOMER hereby agrees that MOTOROLA is not liable, in whole or in part, for any claims or

damages arising from such use, and further agrees to indemnify and hold MOTOROLA harmless from any claim, loss, cost or damage arising from such use.

EXCEPT AS SPECIFICALLY STATED ABOVE, THE PRODUCTS ARE PROVIDED "AS IS" AND MOTOROLA MAKES NO OTHER WARRANTIES EXPRESS, IMPLIED, STATUTORY, OR OTHERWISE REGARDING THE PRODUCTS. MOTOROLA SPECIFICALLY DISCLAIMS ANY IMPLIED WARRANTIES OF MERCHANTABILITY AND FITNESS FOR A PARTICULAR PURPOSE, OR ARISING FROM A COURSE OF DEALING OR USAGE OF TRADE.

Under no circumstances shall MOTOROLA be liable to CUSTOMER or any other party for any costs, lost revenue or profits or for any other special, incidental or consequential damages, even if MOTOROLA has been informed of such potential loss or damage. And in no event shall MOTOROLA's liability to CUSTOMER for damages of any nature exceed the total purchase price CUSTOMER paid for the Product at issue in the dispute, except direct damages resulting from patent and/or copyright infringement, which shall be governed by the "INDEMNITY" Section of this Agreement.

The preceding states MOTOROLA's entire liability for MOTOROLA's breach or failure to perform under any provision of this Agreement.

Warranty Notification

Motorola guarantees to you, the original purchaser, the OEM Module and accessories which you have purchased from an authorized Motorola dealer (the "Products"), to be in conformance with the applicable Motorola specifications current at the time of manufacture for a term of [1] year from date of purchase of the Product(s) (Warranty Term).

You must inform Motorola of the lack of conformity to the applicable specifications of any of the Products within a period of two (2) months from the date on which you detect a defect in material, workmanship or lack of conformity and in any event within a term not to exceed the Warranty Term, and must immediately submit the Product for service to Motorola's Authorized Repair or Service Center. Motorola shall not be bound by Product related statements not directly made by Motorola nor any warranty obligations applicable to the seller.

A list of the Motorola Call Center numbers is enclosed with this Product.

During the Warranty term, Motorola will, at its discretion and without extra charge, as your exclusive remedy, repair or replace your Product which does not comply with this warranty; or failing this, to reimburse the price of the Product but reduced to take into account the use you have had of the Product since it was delivered. This warranty will expire at the end of the Warranty Term.

This is the complete and exclusive warranty for a Motorola OEM Module and accessories and in lieu of all other warranties, terms and conditions, whether express or implied.

Where you purchase the product other than as a consumer, Motorola disclaims all other warranties, terms and conditions express or implied, such as fitness for purpose and satisfactory quality.

In no event shall Motorola be liable for damages nor loss of data in excess of the purchase price nor for any incidental special or consequential damages* arising out of the use or inability to use the Product, to the full extent such may be disclaimed by law.

This Warranty does not affect any statutory rights that you may have if you are a consumer, such as a warranty of satisfactory quality and fit for the purpose for which products of the same type

are normally used under normal use and service, nor any rights against the seller of the Products arising from your purchase and sales contract.

(*including without limitation loss of use, loss of time, loss of data, inconvenience, commercial loss, lost profits or savings.

How to Get Warranty Service?

In most cases the authorized Motorola dealer which sold and/or installed your Motorola OEM Module and original accessories will honor a warranty claim and/or provide warranty service. Alternatively, for further information on how to get warranty service please contact either the customer service department of your service provider or Motorola's service centers, listed in Chapter 3.

Claiming

In order to claim the warranty service you must return the OEM Module and/or accessories in question to Motorola's Authorized Repair or Service Center in the original configuration and packaging as supplied by Motorola. Please avoid leaving any supplementary items like SIM cards. The Product should also be accompanied by a label with your name, address, and telephone number; name of operator and a description of the problem.

In order to be eligible to receive warranty service, you must present your receipt of purchase or a comparable substitute proof of purchase bearing the date of purchase. The phone should also clearly display the original compatible electronic serial number. Such information is contained with the Product.

You must ensure that all and any repairs or servicing is handled at all times by a Motorola Authorized Service Center in accordance with the Motorola Service requirements

In some cases, you may be requested to provide additional information concerning the maintenance of the Products by Motorola Authorized Service Centers only, therefore it is important to keep a record of any previous repairs, and make them available if questions arise concerning maintenance

Conditions

This warranty will not apply if the type or serial numbers on the Product has been altered, deleted, duplicated, removed, or made illegible. Motorola reserves the right to refuse free-of-charge warranty service if the requested documentation can not be presented or if the information is incomplete, illegible or incompatible with the factory records.

Repair, at Motorola's option, may include reflashing of software, the replacement of parts or boards with functionally equivalent, reconditioned or new parts or boards. Replaced parts, accessories, batteries, or boards are warranted for the balance of the original warranty time period. The Warranty Term will not be extended. All original accessories, batteries, parts, and OEM Module equipment that have been replaced shall become the property of Motorola. Motorola does not warrant the installation, maintenance or service of the products, accessories, batteries or parts.

Motorola will not be responsible in any way for problems or damage caused by any ancillary equipment not furnished by Motorola which is attached to or used in connection with the

Products, or for operation of Motorola equipment with any ancillary equipment and all such equipment is expressly excluded from this warranty.

When the Product is used in conjunction with ancillary or peripheral equipment not supplied by Motorola, Motorola does not warrant the operation of the Product/peripheral combination and Motorola will not honor any warranty claim where the Product is used in such a combination and it is determined by Motorola that there is no fault with the Product. Motorola specifically disclaims any responsibility for any damage, whether or not to Motorola equipment, caused in any way by the use of the OEM Module, accessories, software applications and peripherals (specific examples include, but are not limited to: batteries, chargers, adapters, and power supplies) when such accessories, software applications and peripherals are not manufactured and supplied by Motorola.

What is Not Covered by the Warranty

This warranty is not valid if the defects are due to damage, misuse, tampering, neglect or lack of care and in case of alterations or repair carried out by unauthorized persons.

The following are examples of defects or damage not covered by this product warranty

1. Defects or damage resulting from use of the Product in other than its normal and customary manner.
2. Defects or damage from misuse, access to incompatible sources, accident or neglect.
3. Defects or damage from improper testing, operation, maintenance, installation, adjustment, unauthorized software applications or any alteration or modification of any kind.
4. Breakage or damage to antennas unless caused directly by defects in material or workmanship.
5. Products disassembled or repaired other than by Motorola in such a manner as to adversely affect performance or prevent adequate inspection and testing to verify any warranty claim.
6. Defects or damage due to range, coverage, availability, grade of service, or operation of the cellular system by the cellular operator.
7. Defects or damage due to moist, liquid or spills of food.
8. Control unit coil cords in the Product that are stretched or have the modular tab broken.
9. All plastic surfaces and all other externally exposed parts that are scratched or damaged due to customer normal use.

Depending on operating conditions and your usage habits, wear and tear might take place of components including mechanical problems related to Product housing, paint, assembly, sub-assemblies, displays and keyboards and any accessories which are not part of the Product's in-box configuration. The rectification of faults generated through wear and tear and the use of consumable items like batteries beyond their Optimum Performance Time as indicated in the product manual is considered to be your responsibility and therefore Motorola will not provide the free Warranty repair service for these items

Installed Data

Please make and retain a note of all data you have inserted into your Product for example names, addresses, phone numbers, user and access codes, notes etc. before submitting your Product for a Warranty service as such data may be deleted or erased as part of the repair or service process.

Please note if you have downloaded material onto your Product, these may be deleted or erased as part of the repair process or testing process. Motorola shall not be responsible for such matters. The repair or testing process should not affect any such material that was installed by Motorola on your Product as a standard feature.

Out of Warranty Repairs

If you request Motorola to repair your Product any time after the Warranty term or where this warranty does not apply due to the nature of the defect or fault, then Motorola may in its discretion carry out such repairs subject to you paying Motorola its fees for such a repair or it may refer you to an authorized third party to carry out such repairs.

Revision History

Manual Number

6802985C05-A

Manual Title

Developer's Kit

Version Information

The following table lists the manual version, date of version, and remarks about the version required.

Revision History

Version	Date Issue	Remarks
A	March 31, 2008	Initial Release

Chapter 1: Introduction

General Description

The W24 Developer's Kit is intended for evaluating the W24 module, as well as for developing and testing software applications for it.

The main component of the W24 Developer's Kit is the Developer Board, which is mounted in a chassis. The kit includes a cover for the Developer Board. The cover has openings on the top and sides to accommodate the Developer Board's external connectors.

Figure 1-1 shows the Developer's Kit top view with cover; Figure 1-2 shows the front view; Figure 1-3 shows the left side view; Figure 1-4 shows the rear view; Figure 1-5 shows the right side view.

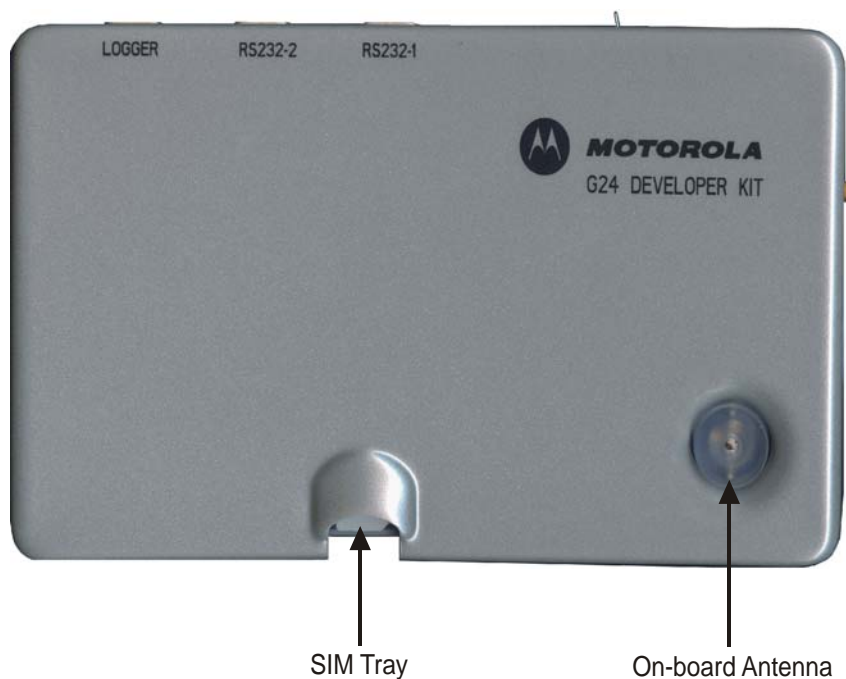

Figure 1-1: W24 Developer's Kit—Top View with Cover

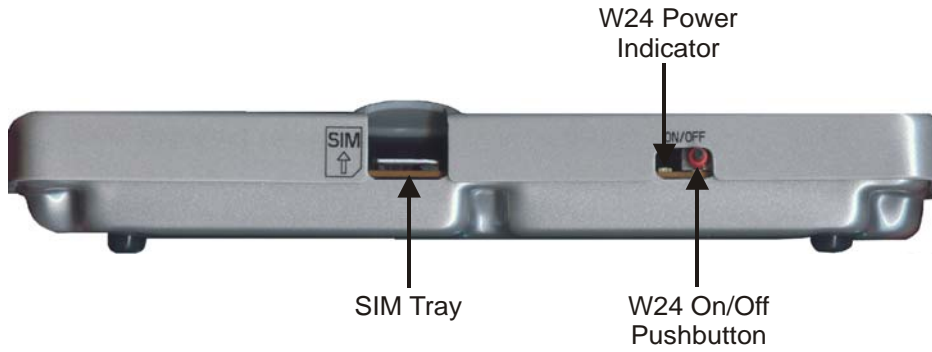

Figure 1-2: W24 Developer's Kit—Front View with Cover

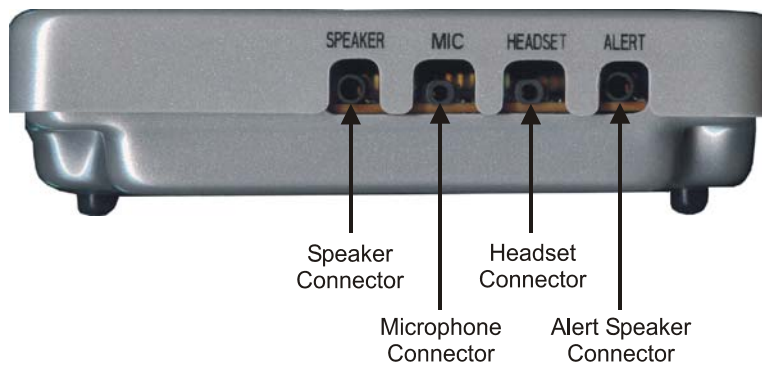

Figure 1-3: W24 Developer's Kit—Left Side View with Cover

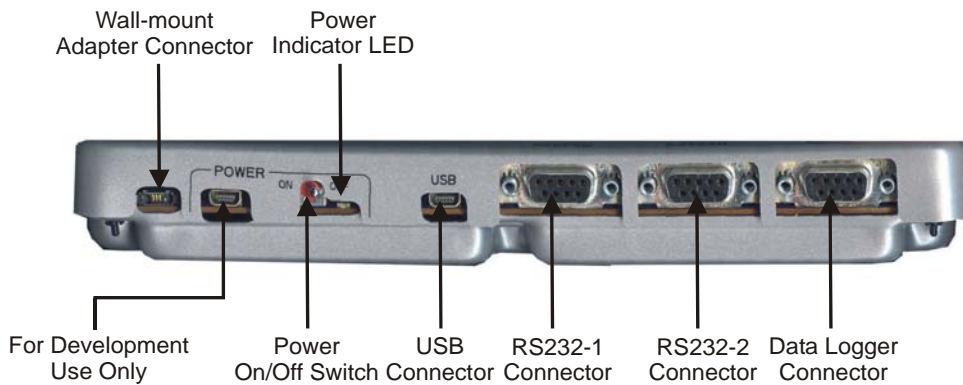

Figure 1-4: W24 Developer's Kit—Rear View with Cover

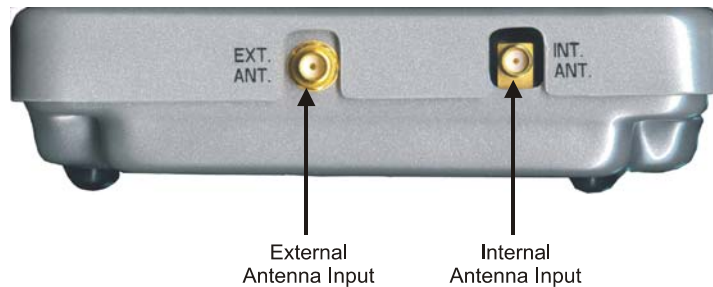

Figure 1-5: W24 Developer's Kit—Right Side View with Cover

Package Contents

The W24 Developer's Kit includes the Developer Board, chassis, cover and standard accessories, which enable you to better utilize the board. The kit and its components are described in Table 1-1.

Table 1-1: W24 Developer's Kit Package Contents

Description	Part No.	Quantity
Antenna Stub	8588912N02	1
Wi-Fi Antenna	8586381J18	1
Developer Board	FCN5540C	1
Developer Board Top Cover	1588522V58	1
Developer Board Bottom Cover	1588522V59	1
Documentation CD	FVN5423A	1
European Plug for Adapter	SYN7456A	1
M2/4mm Screw (for W24 fastening)	0383408P01	2
Spacer (for G24 mounting)	4371697Y01	2
Mono Headset	SYN8390B	1
RF cable between internal antenna and external connectors	3087568V01	1
RF cable with MMCX connector between W24 and external antenna connector	3087568V02	1
RS232 Cable	3086159U69	1
Test SIM Card	8102316T02	1
Mini-AB USB Cable	SKN6371B	1
Wall Mount Power Adapter	SPM4250A	1

Figure 1-6 shows the W24 Developer's Kit, including the Developer Board (without cover), the W24 and some accessories.

Important: The Developer's Kit does not include a W24 device. The W24 must be obtained separately.

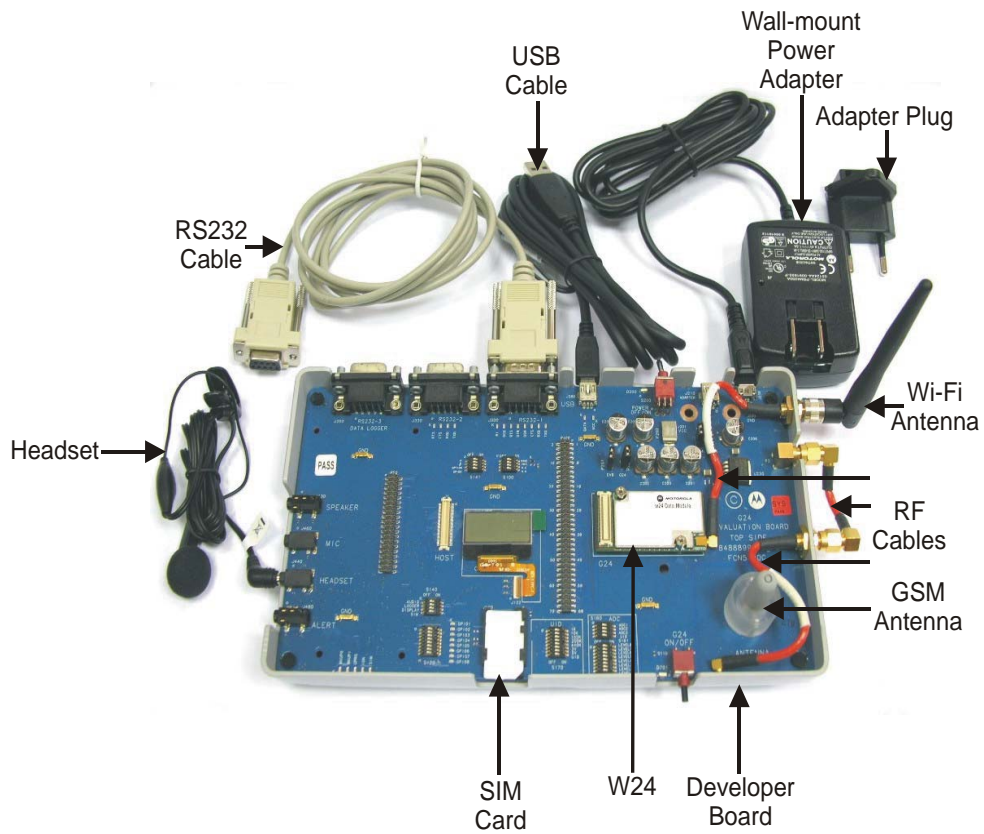

Figure 1-6: W24 Developer's Kit with Board, W24 and Accessories

Chapter 2: Developer Board and Interfaces Description

This chapter contains the following sections:

- **Overview**—provides an overview of the Developer Board
- **Initial Setup**—describes how to set up and prepare the Developer Board for first-time use
- **Configuration**—describes how to modify the default settings to control the operation of the Developer Board
- **Components and Specifications**—lists each connector, switch, jumper, option switch, and LED. Also provides other details and specifications for the Developer Board

Overview

The W24 Developer Board is designed to support the hardware and software development and validation of the W24 Wi-Fi data module. The Developer Board provides a peripheral platform to operate the W24 as a standalone product, or in conjunction with the G24 cellular module.

Developer Board Features and Structure

The Developer Board provides these features to facilitate software and hardware development:

- Easy access to W24 70-pin interface connector signals, through a large header connector and an external host connector
- Wall adapter and DC power supplies for board operation
- LED indicators for critical signals
- USB and RS232 serial interfaces
- Data logger interface for W24 debugging
- Digital audio interface
- Analog audio interface for speaker, alert speaker, microphone and headset
- SIM card interface
- Switches and jumpers for controlling board operation

[Figure 2-1](#) shows the Developer Board structure:

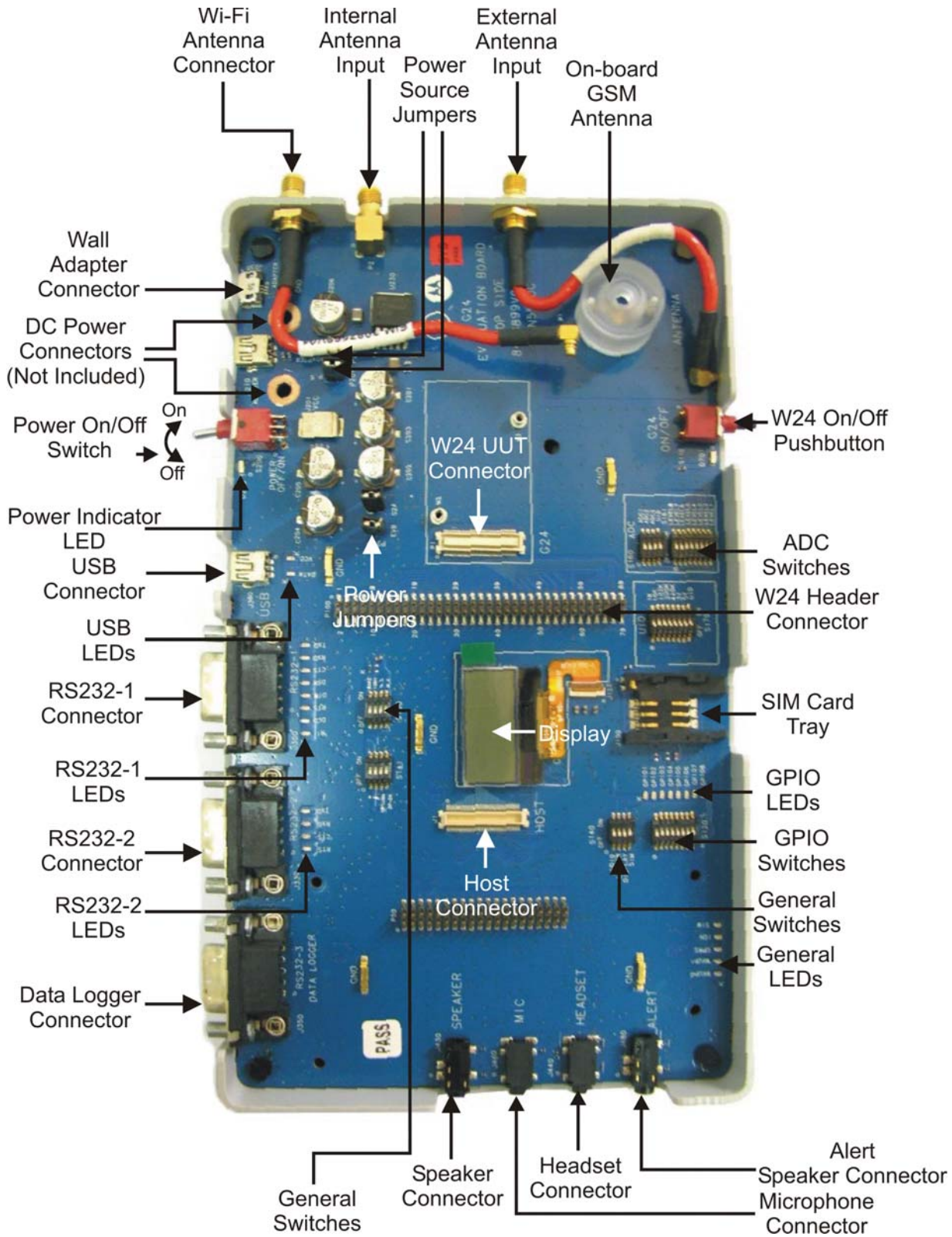

Figure 2-1: Developer Board Structure

Initial Setup

This section describes the initial procedure for setting up the Developer Board for W24 testing and evaluation. The tasks in this section need to be performed only once, prior to initial use of the Developer's Kit. After performing the initial setup, you can modify the default settings or use different peripheral devices, as described in "Configuration" on page 12.

Perform the steps in this section in sequence.

Before starting, remove the cover of the Developer Board. The cover simply slides up off the board, and does not require the removal of any screws or clips. After setting up the Developer Board, replace the cover simply by pushing it gently back into place. Make sure the cover is aligned properly with the external connectors on the side of the board.

Note: Numbers that appear in parentheses throughout the following paragraphs (Jxxx, Sxxx, etc.), refer to components reference designation numbers as they are given on the developer board and in the schematic diagrams.

Connecting the W24

To Connect the W24 to the Developer Board (Stand alone configuration)

1. Place the W24 (Figure 2-2) on the Developer Board area, marked by a white rectangle, and push the W24 70-pin connector down into the W24 70-pin connector on the Developer Board.

The two screw holes on the W24 should be aligned with the W24 spacers (denoted by M2 and M3).

2. Fasten the W24 to the Developer Board using the two M2 screws provided with the kit.
3. Connect the internal Wi-Fi RF cable MMCX connector to the MMCX connector of the W24 by pushing it in until it clicks (Figure 2-2).
4. Connect the external Wi-Fi RF antenna to Wi-Fi antenna connector (Figure 2-2).
5. Connect the internal Wi-Fi RF cable MMCX connector to the MMCX connector of the W24 by pushing it in until it clicks (Figure 2-2).

This connects the W24 to the antenna.

To Connect the W24 + G24 to the Developer Board (Stacked configuration)

1. Perform steps 1, 3, 4, 5 of the above procedure.
2. Fasten the W24 to the Developer Board using the two G24 spacers provided with the kit.
3. Place the G24 (Figure 2-3) on top of the W24.
4. Fasten the G24 to the Developer Board using the two M2 screws provided with the kit.
5. Insert the External Antenna Connector into the dedicated hole in the Developer Board cover and close nut.
6. Connect the external RF cable between the External Antenna Connector and the Internal Antenna Connector (Figure 2-3).
7. Connect the internal GSM RF cable MMCX connector to the MMCX connector of the G24 by pushing it in until it clicks (Figure 2-3).

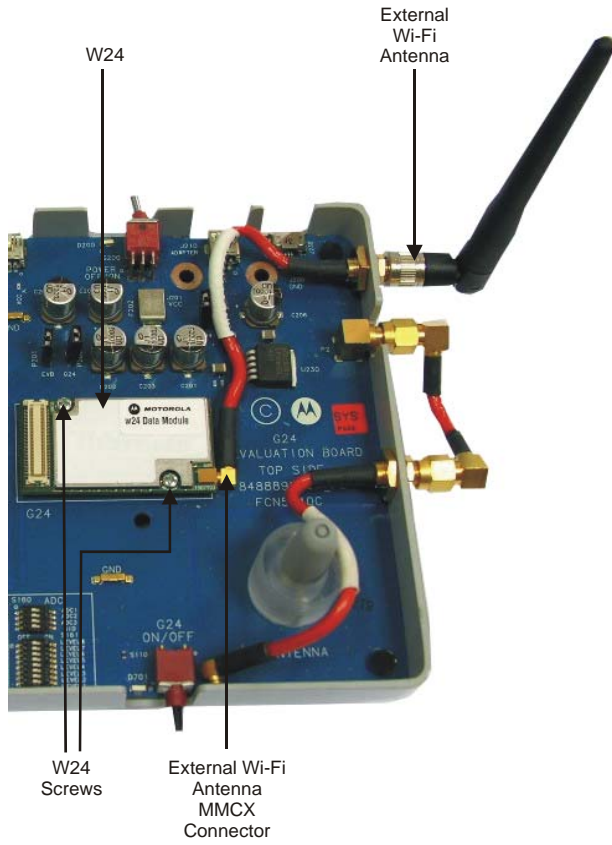

Figure 2-2: Connecting the W24 (Stand alone configuration)

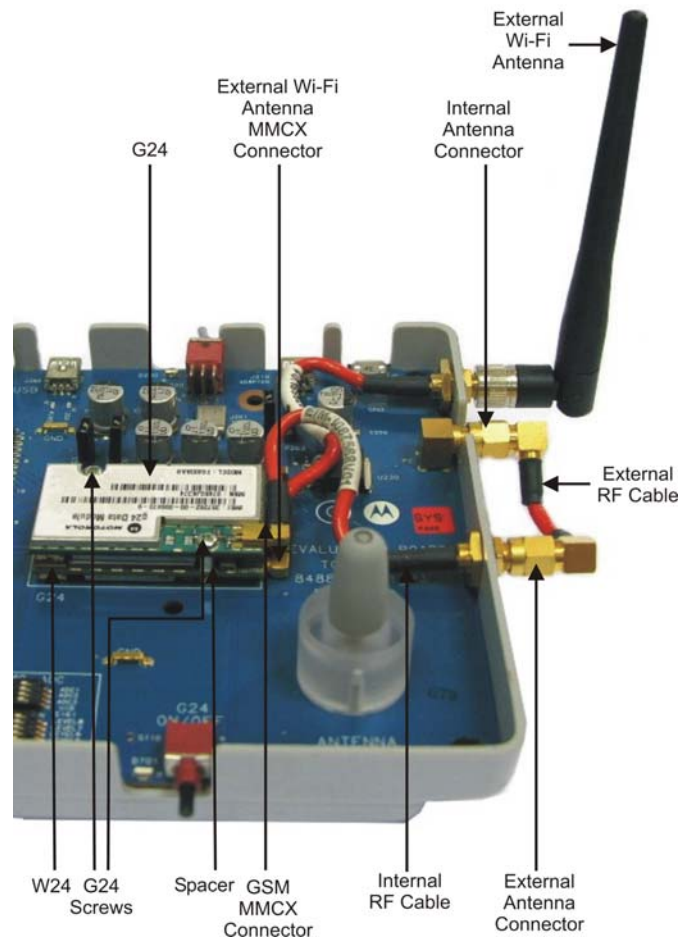

Figure 2-3: Connecting the W24 + G24 (Stacked configuration)

Connecting External Accessories

Replace the Developer Board cover and connect the following external connectors in the sequence shown.

Power Supply

Caution: Before connecting the power supply, make sure that the Developer Board On/Off switch (located in the rear of the board, as shown in [Figure 2-4, on page 10](#)) is in the **OFF** position.

To Connect the Power Supply

1. Connect the supplied Wall adapter to the Wall Adapter Connector (J230) ([Figure 2-4](#)).

*The Wall Adapter Connector is located to the left of the Developer Board On/Off switch (labeled **Power**) at the rear of the Developer Board.*

2. Plug the adapter into a wall outlet.

Note: The W24 Developer Board can also be powered by an external DC power supply. This option is described in “[Configuration](#)” on page 12.

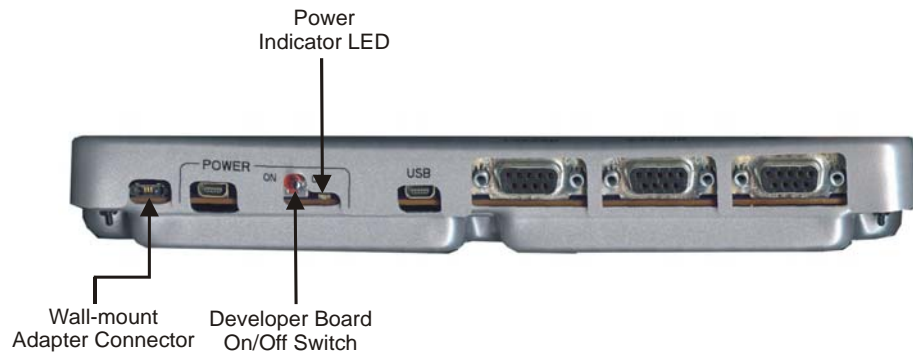

Figure 2-4: Developer Board Power Switch and Adapter Connector (Rear)

Serial Communications

USB and RS232 serial interfaces are available for communicating with a PC. The W24 Developer’s Kit includes the necessary RS232 and USB cables for connecting to a PC.

To Connect Serial Communication Cables

- Connect ([Figure 2-4](#)) either the supplied RS232 cable with a male D-type connector to RS232-1 connector (J300), or the supplied Mini-AB USB cable to the USB connector (J380).

*The RS232 and USB connectors are located to the right of the Developer Board On/Off switch (labeled **Power**) at the rear of the Developer Board.*

Audio Devices

Note: W24 used in a stand alone configuration, has no audio capabilities. When used in a stacked configuration (with G24), audio capabilities are demonstrated for G24 use only (refer to 6889192V26).

SIM Card

Note: W24 used in a stand alone configuration, has no SIM capabilities. When used in a stacked configuration (with G24), SIM capabilities are demonstrated for G24 use only (refer to 6889192V26).

Antenna

To Attach the Wi-Fi Antenna (Both configurations)

- Screw the supplied antenna into the antenna connector, located at the side of the Developer's Kit ([Figure 2-3, on page 9](#)).

To Attach the GSM Antenna (Stacked configuration)

- Screw the supplied antenna into the antenna base, located at the bottom-right corner on top of the Developer's Kit.

*The Developer's Kit arrives configured to operate with its on-board internal antenna. The **EXT ANT** and **INT ANT** connectors are connected together using an external RF cable, on the board's right side (Figure 2-2, on page 8).*

Power Up

Important: You must turn the Developer Board power on before turning on the W24.

To Turn on the Power

1. Turn on the Developer Board power by switching the power On/Off switch (S200) to **ON** (Figure 2-4, on page 10).

*The Developer Board power On/Off switch (labeled **Power**) is located at the rear of the Developer Board.*

The Developer Board power indicator LED is lit.

2. Turn on the W24 power by pressing the On/Off pushbutton (S110) for at least 0.5 seconds (Figure 2-5).

The W24 power On/Off pushbutton is located at the front of the Developer Board.

The W24 On/Off LED is lit.

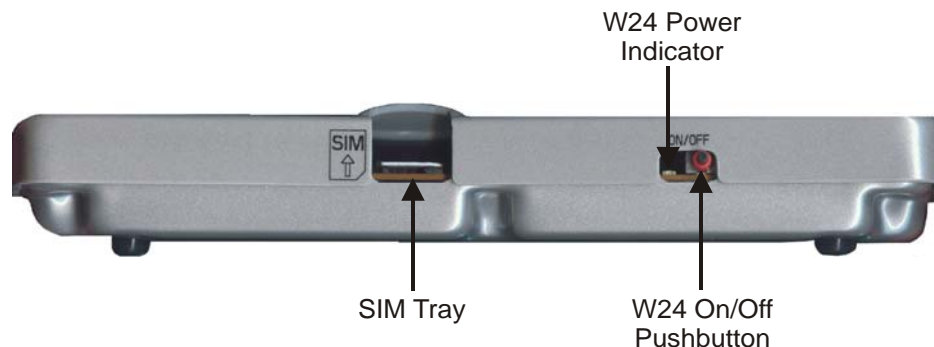

Figure 2-5: W24 On/Off Pushbutton and Power Indicator LED

Initial Setup of the Developer Board is now complete and the board is ready for use.

Configuration

After performing Initial Setup (previous section), you can continue using the Developer Board this default setup. This section describes how to change the default setup so you can use different peripherals or change default board operation.

Alternate Power Sources

The Developer Board power can be supplied from:

- Wall mount power adapter (see [“Wall Mount Adapter Operation”](#) on page 13)
- External DC power source (see [“DC Power Source Operation”](#) on page 13)

A single power source is used for the W24 and the board peripherals.

You must connect the Developer Board to a power source, and then set the power source jumper (P204), if necessary (see [“Selecting the Power Source”](#) on page 15).

Two other jumpers (Figure 2-6) help control the power supply in the Developer Board:

- **P201**—Connects/disconnects the power from the Developer Board peripherals
- **P200**—Connects/disconnects the power from the W24

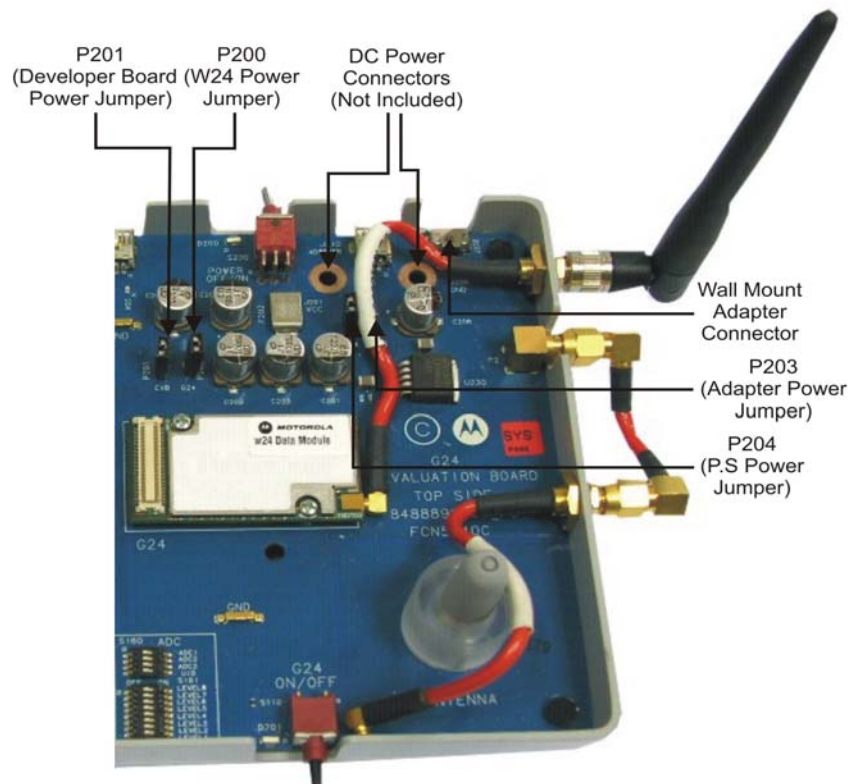

Figure 2-6: Power Supply Connectors, Jumpers and Switches

Each power supply option is described in the sections that follow.

Wall Mount Adapter Operation

To Use a Wall Mount Adapter

1. Connect the Wall mount adapter to the Power Adapter connector (J230) (Figure 2-7)
2. Verify that jumper P203 is connected and jumper P204 is disconnected (default setup).

Important: Verify that the Wall mount adapter is not connected to the USB connector (J380).

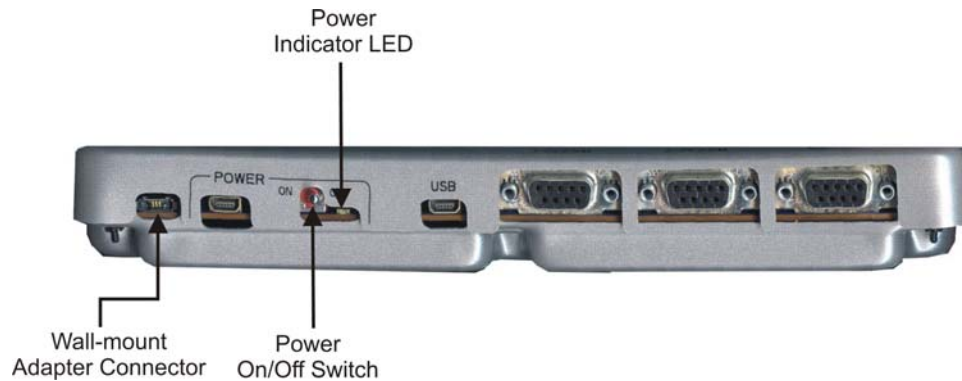

Figure 2-7: W24 Developer's Kit Wall Mount Adapter Connector

The Wall Mount Adapter connector is located at the rear of the Developer Board, immediately to the left of the Power On/Off switch.

The Wall Mount Adapter connector pinout is described in Table 2-1. The adapter supplies a constant voltage, which is regulated to a nominal 4.1 V on the Developer Board.

Table 2-1: Wall Mount Adapter Connector Pinout (J230)

Pin #	Pin Name
1	GND
2	Detection circuit
3	VCC

DC Power Source Operation

To Use an External DC Power Supply

1. Remove the Developer Board cover.

When using the DC power input connectors, the Developer Board cover must be removed.

2. Attach the DC input connectors to the Developer Board (Figure 2-8).

Note: The DC input connectors are not included and should be purchased separately.

Use the red connector for VCC and the black one for GND.

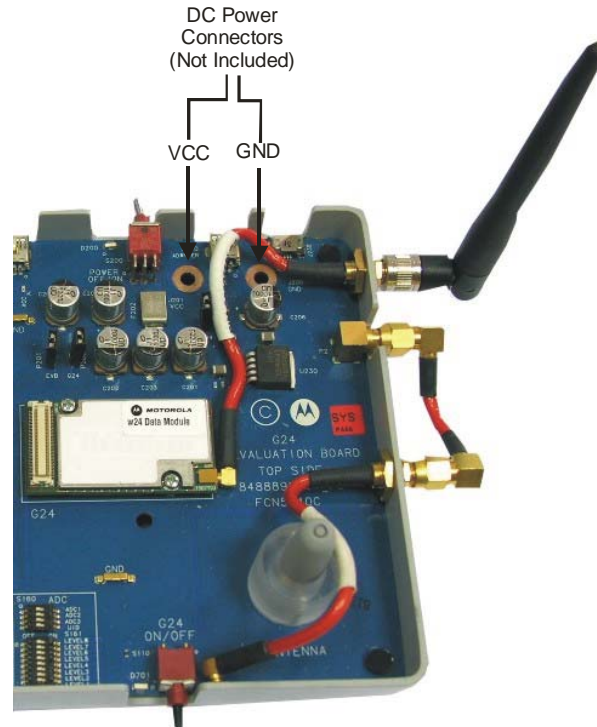

Figure 2-8: DC Input Connectors

3. Connect the external DC power supply to the **VCC** (J201) and **GND** (J200) connectors using banana plugs, alligator clips or wire.
4. Move jumper P203 to jumper P204.

Important: The DC voltage applied through this connection should not exceed the recommended operational limits of 3.3 V to 4.2 V. In any case, the DC source input is protected from over voltage and reverse polarity, and includes a protective fuse.

Important: The DC power source should not be used when other sources are connected.

Selecting the Power Source

The Developer Board can be powered using two different power sources:

- Wall-mount power adapter (default source)
- External DC power supply

Important: Only one power source can be used at any given time.

Two jumpers are used for selecting the power source - P203 for Wall-mount adapter and P204 for the external DC power supply (Figure 2-6, on page 12). The jumpers position for each power source is described in Table 2-2.

Table 2-2: Power Source Jumpers (P203, P204)

Reference	Description	Jumper Connected	Jumper Not Connected
P203	Wall-mount adapter power selection jumper	Wall mount adapter is used as the power source for the W24 Developer board.	Wall adapter is NOT used.
P204	External DC power selection power.	DC power is used as the power source for the W24 Developer board.	DC power is NOT used.

Disconnecting Power

The Developer Board and W24 supplies are separated by two jumpers (P200, P201) (Figure 2-6, on page 12) that allow disconnecting the power to the Developer Board or to the W24.

Developer Board. Disconnecting power to the Developer Board is generally used to diagnose a problem that may be caused by the board. This is independent of power supply to the W24, which will continue to receive power. The Developer Board Power jumper (P201) (Figure 2-6, on page 12) positions for connecting and disconnecting power to the Developer Board are shown in Table 2-3.

W24. Disconnecting the power to the W24 is generally used to connect an amperometer to the jumper's two pins to measure the current through the W24. The W24 Power Jumper (P200) (Figure 2-6, on page 12) positions for connecting and disconnecting power to the W24 are shown in Table 2-3.

Table 2-3: W24 Power Jumpers (P200, P201)

Reference	Description	Jumper Connected	Jumper Not Connected
P200	Connects/Disconnects W24 power.	W24 power is connected.	W24 power is Disconnected.
P201	Connects/Disconnects Developer board power.	Developer board power is connected.	Developer board power is Disconnected.

Communication Interfaces

The W24 Developer Board includes four serial interfaces (Figure 2-9):

- Primary RS232-1
- Secondary RS232-2
- USB
- Data logger

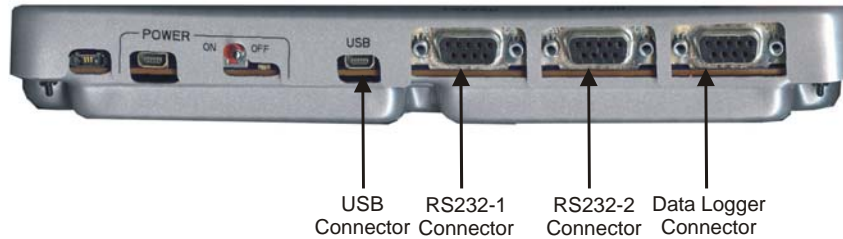

Figure 2-9: USB, RS232-1, RS232-2 and Data Logger Connectors

Note: For selecting communication channel, refer to AT+iHIF command in the W24 ATi Commands Developer’s Guide (6802985C10).

Each of these serial interfaces is described in the sections that follow.

RS232-1

The 9-pin, D-type RS232-1 serial port (J300) is the primary interface to the W24. The W24 UART signals are active-low CMOS-level signals (0-2.7 V), which are converted by the Developer Board to standard RS232 levels for PC communications. The RS232-1 Connector Pinout (J300) is shown in Table 2-4.

Note: The RS232-1 connector pin names are DTE-oriented.

Table 2-4: RS232-1 Connector Pinout (J300)

Pin #	Description	DTE I/O
1	DCD	In
2	RXD	In
3	TXD	Out
4	DTR	Out
5	Ground	
6	DSR	In
7	RTS	Out
8	CTS	In
9	RI	In

RS232-2

Note: W24 used in a stand alone configuration, has no RS232-2 capabilities. When used in a stacked configuration (with G24), RS232-2 capabilities are demonstrated for G24 use only (refer to 6889192V26).

USB

The USB interface connector (J380) is a standard Mini-B USB device interface. The W24 USB signals are routed directly to this connector. The USB Connector pinout (J380) is shown in [Table 2-5](#).

Table 2-5: USB Connector Pinout (J380)

Pin #	Description
1	VCC
2	D-
3	D+
4	UID (for development only)
5	Ground

Data Logger

The 9-pin D-type Data Logger serial port (J350) is used for development only.

Audio Interface

Note: W24 used in a stand alone configuration, has no audio capabilities. When used in a stacked configuration (with G24), audio capabilities are demonstrated for G24 use only (refer to 6889192V26).

Antenna

An external Wi-Fi antenna must be connected to the Developer Board for adequate Wi-Fi reception. You must connect the W24 to the external antenna connector and connect the Wi-Fi antenna on the dedicated right side connector.

In Stacked configuration, an antenna (internal or external) must be connected to the Developer Board for adequate GSM reception. You must connect the G24 to either the on-board internal antenna or to an external antenna.

Two RF connectors on the right side of the Developer Board, labeled **INT ANT** and **EXT ANT**, are used for setting up the GSM antenna (Figure 2-10).

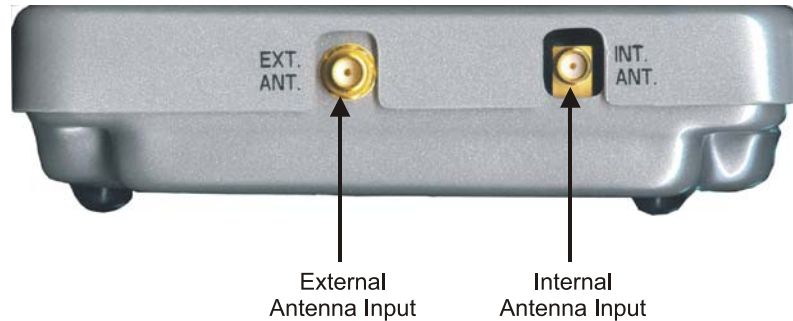

Figure 2-10: Antenna Connectors (external)

On the inside of the Developer Board, the **EXT ANT** connector is connected to the G24 and the **INT ANT** is connected to the on-board internal antenna.

To Connect to the Wi-Fi External Antenna (Both configurations)

- Connect a Wi-Fi external antenna to the **Wi-Fi** connector (Figure 2-11)..

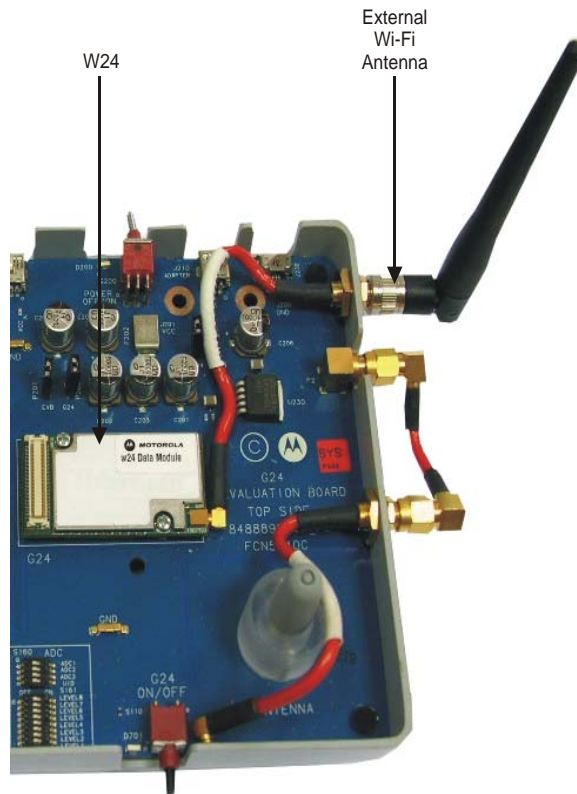

Figure 2-11: Wi-Fi Antenna Connection

To Connect to the GSM Internal Antenna (Stacked configuration)

- Connect the **EXT ANT** and **INT ANT** connectors with the additional RF cable supplied in the Developer's Kit (Figure 2-12).

Note: This is the Developer Board's default configuration. The board arrives with the **EXT ANT** and **INT ANT** already connected.

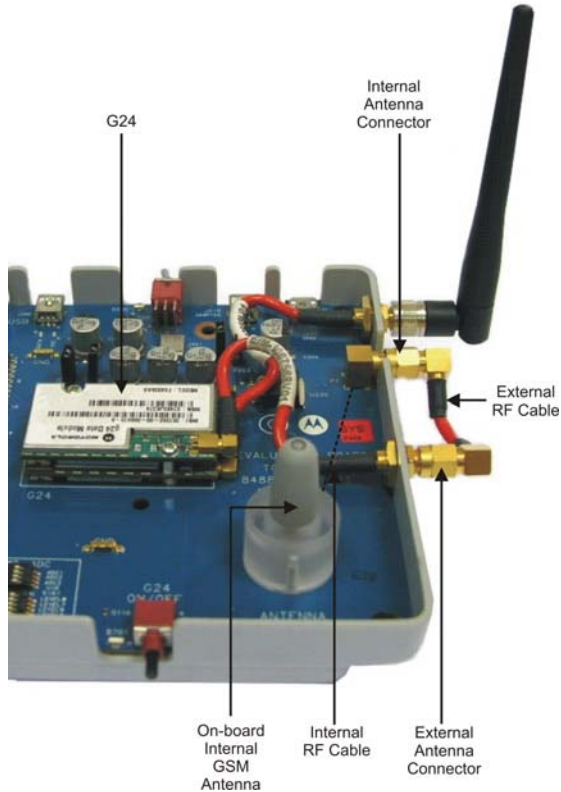

Figure 2-12: Antenna Connectors (internal)

To Connect to GSM External Antenna (Stacked configuration)

1. Disconnect the external RF cable from the **EXT ANT** connector.
2. Connect an external antenna or antenna application to the **EXT ANT** connector (Figure 2-12).

The connection cable is not included.

Option Switches

The Developer Board contains 7 option switches that are described in the following paragraphs.

Analog to Digital Converter (ADC) - S160, S161

Note: W24 used in a stand alone configuration, has no ADC capabilities. When used in a stacked configuration (with G24), ADC capabilities are demonstrated for G24 use only (refer to 6889192V26).

General Purpose I/O (GPIO) - S120

Note: W24 used in a stand alone configuration, has no GPIO capabilities. When used in a stacked configuration (with G24), GPIO capabilities are demonstrated for G24 use only (refer to 6889192V26).

Note: When using W24 model TBD, GPIO4 through GPIO7 switches must be in High position (left).

Figure 2-13 shows the GPIO switches provided on the Developer Board, which are located on the S120 component.



Figure 2-13: S120 Switches

GPIO signals mapping is shown in Table 2-6.

Table 2-6: GPIO Signals Mapping

Reference	Description
GPIO1	Map to GPIO1 signal (W24 J1/28)
GPIO2	Map to GPIO2 signal (W24 J1/30)
GPIO3	Map to GPIO3 signal (W24 J1/32)
GPIO4	Map to BT_PRIORITY_GPIO4 signal (W24 J1/34)

Table 2-6: GPIO Signals Mapping (Cont.)

Reference	Description
GPIO5	Map to BT_FREQ_GPIO5 signal (W24 J1/36)
GPIO6	Map to BT_STATE_GPIO6 signal (W24 J1/38)
GPIO7	Map to WL_ACTIVE_GPIO7 signal (W24 J1/40)
GPIO8	Map to GPIO8 signal (W24 J1/42)

UID - S170

The UID S170 switches are used for development purpose only.

Figure 2-14 shows the UID switches provided on the Developer Board, which are located on the S170 component.

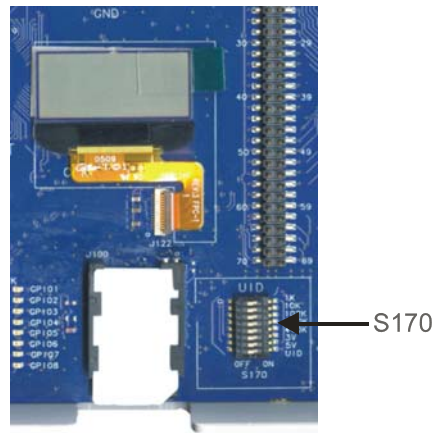

Figure 2-14: S170 Switches

General Function Switch - S140

Note: W24 used in a stand alone configuration, has no general function capabilities. When used in a stacked configuration (with G24), general function capabilities are demonstrated for G24 use only (refer to 6889192V26).

General Function Switch - S141

The S141 switches are used for development purpose only and should remain at OFF (left position) for proper use of the W24.

Figure 2-15 shows the S141 switches.

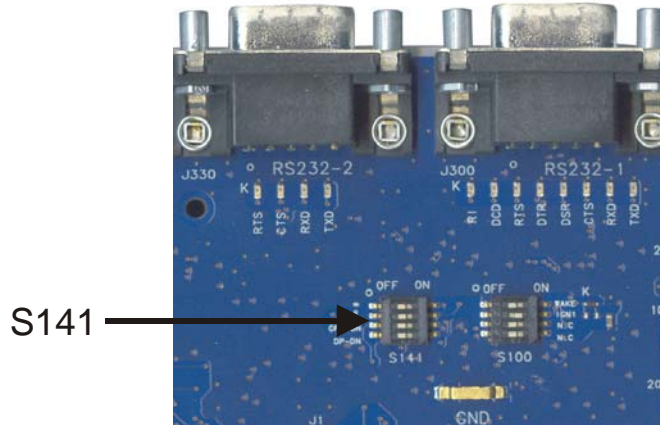

Figure 2-15: S141 Switches

General Function Switch - S100

Figure 2-16 shows the S100 switches.

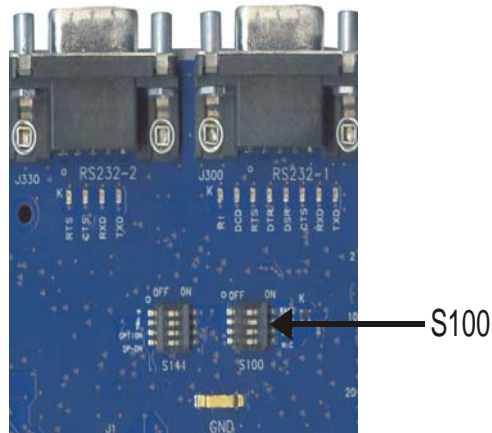

Figure 2-16: S100 Switches

The S100 switches description and functionality are shown in [Table 2-7](#).

Table 2-7: S100 Switches Functionality

Reference	Description	"Off" State	"On" State
WAKE	The WAKEUP switch is connected to the W24's internal wakeup interrupt module using the WKUPI_N signal.	Sets the WAKEUP switch to OFF to enable entering Sleep mode.	Sets the WAKEUP switch to ON to enable wake up (see Note).
IGN	The IGN switch activates the W24 ignition circuits using the IGN signal.	Turns the W24 off.	Turns the W24 on using the on board 5V booster.

Note: Generally, your application wakes up the W24. In cases where the application is not ready for integration, you can force wakeup of the W24 by setting the switch to **ON**.

SIM Card

Note: W24 used in a stand alone configuration, has no SIM capabilities. When used in a stacked configuration (with G24), SIM capabilities are demonstrated for G24 use only (refer to 6889192V26).

Host Connection

An external application may communicate with the W24 through the host connector (J1) (Figure 2-17) and control some or all of the W24's functions. The host connector enables you to integrate the W24 into an application without installing the W24 inside the product.

The host connector operates in parallel with the Developer Board peripherals and enables an external application to share W24 resources with the Developer Board. You may select any W24 function to control externally, through the host connector, and allow the Developer Board to control other functions.

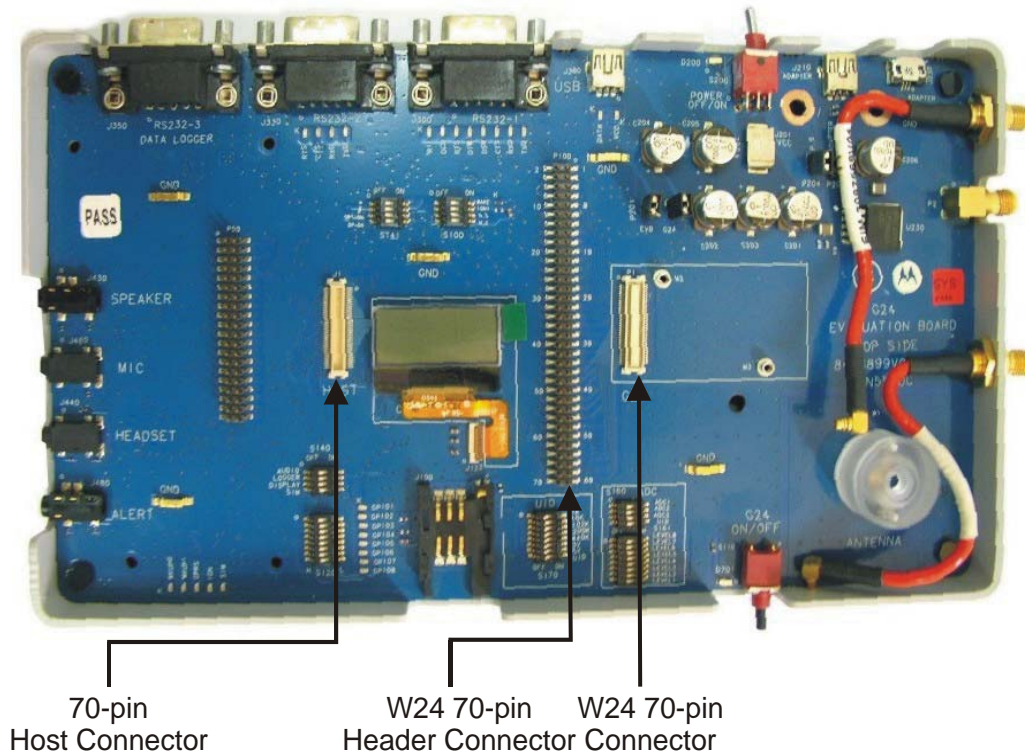

Figure 2-17: 70-pin Connectors

You can connect an external application to the W24 Developer Board using a host interconnect flex cable and connecting it to the host connector (J1). Connect the other end of the cable to the external application. The cable is an optional accessory.

All pin numbers and functions of the host connector are identical to those of the W24 (P1) and the W24 diagnostic connector (P100). For more information on the pins of the host connector, refer to “W24 Interface Connector” on page 28.

These are guidelines for using the host connector:

- When using an external SIM card through the host connector, the Developer Board SIM card tray must be empty
- When using any of the serial communication channels (USB, RS232, LOGGER) through the host connector, the Developer Board serial connectors should not be used
- When using the IGN or WAKEUP functions through the host connector, the functions should be switched off on the Developer Board switches
- When using the analog audio channels through the host connector, disconnect all audio devices from the Developer Board

- When using the PCM digital audio through the host connector, it is recommended to place the audio selection switch (S140 - AUDIO) to analog audio mode (OFF)
- When connecting an external application that provides the power to the W24 and the Developer Board, remove any other power sources from the Developer Board

Components and Specifications

Connectors Description

All the Developer Board connectors are marked by their reference number and by a pin-1 indicator. [Table 2-8](#) describes the available connectors on the Developer Board.

Table 2-8: Developer Board Connectors

Reference	Connector	Description
Internal Connectors (not visible when cover is on)		
P1	W24 UUT	W24 UUT (Unit Under Test) connector
J1	Host	Emulates the W24 connector for host systems
P100	Header	Debug header connector (70-pin)
P50	Header	For development use only
J201	VCC	Developer Board DC power supply
J200	GND	Developer Board common ground
External Connectors (visible when cover is on)		
J380	USB	USB mini AB-type connector
J300	RS232-1	Primary RS232 to PC
J330	RS232-2	Secondary RS232 to PC
J350	RS232-3	RS232 for debugging (diagnostics). For development use only.
J430	Speaker	Hands-free system speaker jack
J460	Microphone	Hands-free system microphone jack
J440	Headset	Headset jack
J480	Alert	Alert speaker jack
J230	AC adapter/charger	Wall-mount adapter connector
J100	SIM card	SIM card socket with detection
P2	Antenna connector	SMA connector for internal antenna
M1	RF Antenna	Internal antenna

W24 Interface Connector

Table 2-9 lists the pin names and functions available for the W24 interface connectors. All pin numbers and functions are identical to the W24 (P1), host (J1) and W24 Diagnostic (P100) connectors on the Developer Board.

Table 2-9: W24 Connectors Pinout

Pin #	Pin Name	Pin #	Pin Name
1	GND	2	GND
3	GND	4	GND
5	VCC	6	VCC
7	VCC	8	VCC
9	RTS_N	10	USB_VBUS
11	RXD_N	12	USB_D+
13	DSR_N	14	USB_D-
15	CTS_N	16	WKUPL_N
17	DCD_N	18	PCM_DIN
19	DTR_N	20	PCM_DOUT
21	TXD_N	22	PCM_CLK
23	RI_N	24	PCM_FS
25	RESET_N	26	WKUPO_N
27	VREF	28	GPIO1
29	RXD2_N	30	GPIO2
31	TXD2_N	32	GPIO3
33	RTS2_N	34	BT_PRIORITY_GPIO4
35	CTS2_N	36	BT_FREQ_GPIO5
37	ADC1	38	BT_STATE_GPIO6
39	TX_EN_N	40	WL_ACTIVE_GPIO7
41	ANT_DET	42	GPIO8
43	ADC2	44	SIM_RST_N
45	UID+MSL	46	SIM_CLK
47	ADC3	48	SIM_VCC
49	GPRS_DET_N	50	SIM_PD
51	IGN	52	SIM_DIO
53	ON_OFF_N	54	LCD_CS
55	HDST_INT_N	56	LCD_SD
57	HDST_MIC	58	LCD_CLK

Table 2-9: W24 Connectors Pinout (Cont.)

Pin #	Pin Name	Pin #	Pin Name
59	AGND	60	WIFI_LED_LCD_RS
61	MIC	62	DNU
63	ALRT_N	64	DNU
65	ALRT_P	66	DNU
67	SPKR_N	68	DNU
69	SPKR_P	70	DNU

Switches and Jumpers

Figure 2-18 shows the jumpers and switches on the Developer Board.

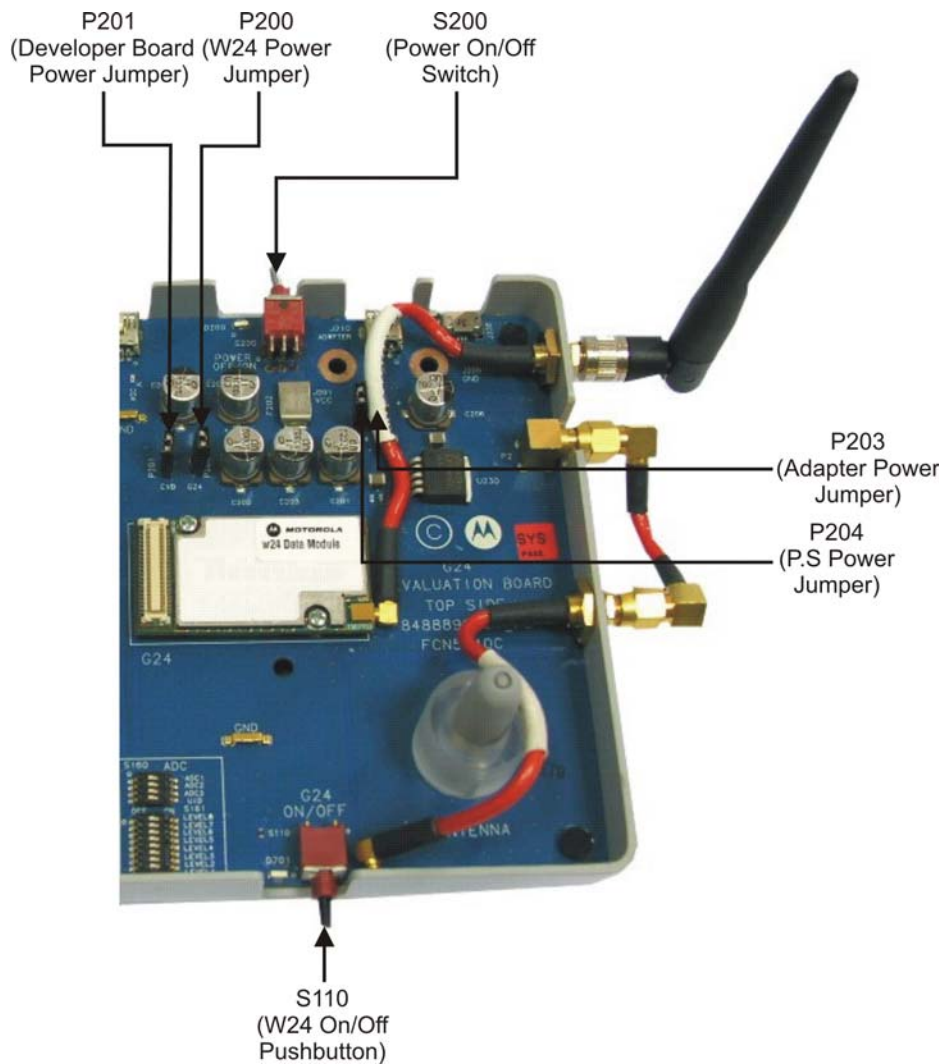

Figure 2-18: Jumpers and Switches on Developer Board

Table 2-10 describes the available switches and jumpers on the Developer Board.

Table 2-10: Developer Board Switches and Jumpers

Reference	Switch/Jumper	Description
Switches		
S200	Board on/off	Developer Board on/off switch
S110	W24 on/off	W24 on/off pushbutton switch
S100	General Function Switch	Four switches for Developer Board options
S141	General Function Switch	Four switches for Developer Board options
S140	General Function Switch	Four switches for Developer Board options
S120	GPIO Switch	Eight switches for GPIO signals
S170	UID Switch	Eight switches for development use only
S160	ADC Switch	Eight switches for simulating ADC signals
S161	ADC Switch	Eight switches for simulating ADC signals

Table 2-10: Developer Board Switches and Jumpers (Cont.)

Reference	Switch/Jumper	Description
Jumpers		
P201	EVB	Peripheral power input jumper
P200	UUT	W24 UUT power input jumper
P203	ADAPTER	Wall mount adapter power source selection jumper
P204	P.S	External power supply, power source selection jumper

LED Indicators

Figure 2-19 shows the LEDs on the Developer Board.

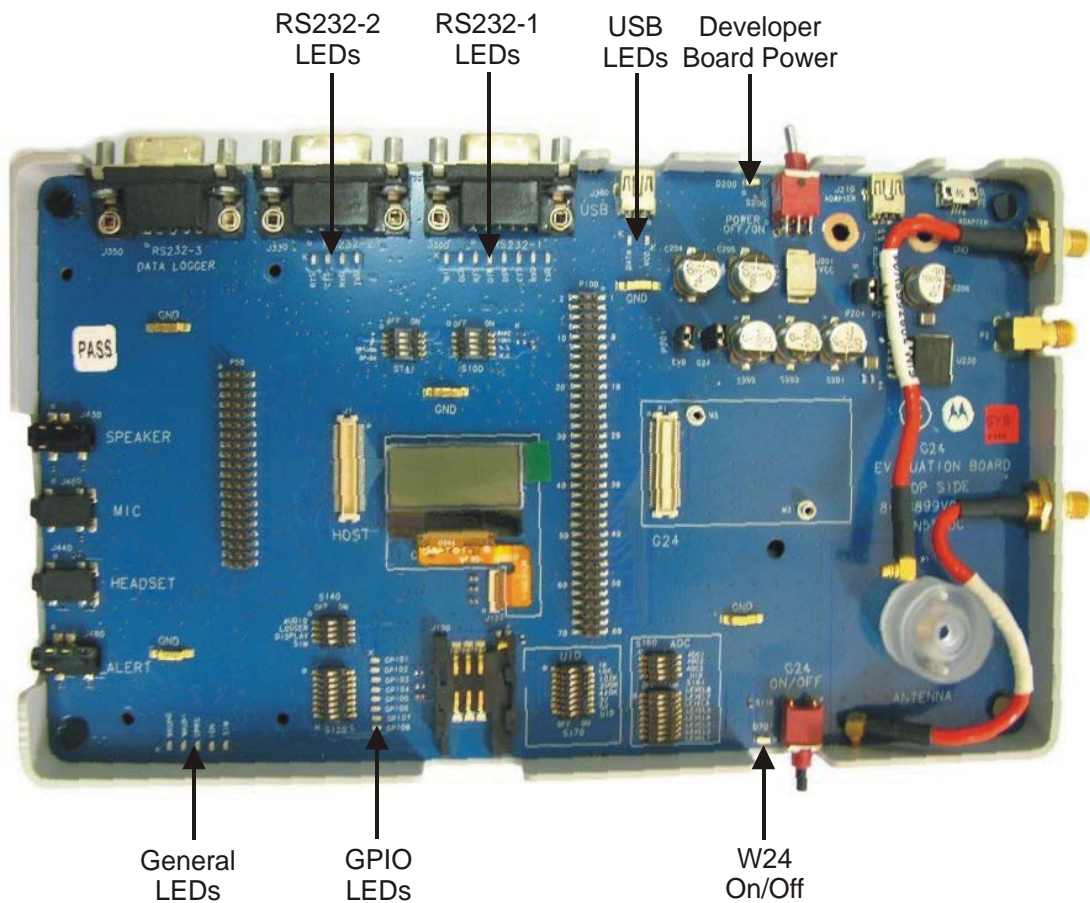

Figure 2-19: LEDs on Developer Board

Table 2-11 describes the LED indicators on the Developer Board. Each LED is marked on the board by the function it represents.

Table 2-11: Developer Board LED Indicators

Group	LED	Reference	Description
General	WAKEUPO	D768	Wake-up out
	WAKEUPI	D704	Wake-up in
	IGN	D702	Ignition input
	GPRS	D710	GPRS/EGPRS coverage indication
	SIM	D707	SIM card reset indication
GPIO	GPIO1	D760	General purpose I/O 1 signal
	GPIO2	D761	General purpose I/O 2 signal
	GPIO3	D762	General purpose I/O 3 signal
	GPIO4	D763	BT_PRIORITY_GPIO4 signal
	GPIO5	D764	BT_FREQ_GPIO5 signal
	GPIO6	D765	BT_STATE_GPIO6 signal
	GPIO7	D766	WL_ACTIVE_GPIO7 signal
	GPIO8	D767	General purpose I/O 8 signal
Power	W24	D701	W24 on/off
	Power	D200	Developer Board Power
USB	VCC	D780	USB VBUS
	DATA	D711	USB D+
RS232-1	RXD	D722	DTE receive data
	TXD	D721	DTE transmit data
	RTS	D724	Request to send
	CTS	D723	Clear to send
	DTR	D725	Data terminal ready
	DSR	D726	Data set ready
	DCD	D727	Carrier detect
	RI	D728	Ring indicator
RS232-2	RXD	D743	DTE receive data
	TXD	D742	DTE transmit data
	CTS	D744	Clear to send
	RTS	D745	Request to send

Chapter 3: Service and Troubleshooting

Service

This section provides contact information for any possible queries that may arise, for example:

- Have questions?
- Having trouble getting the Developer Board set up?
- Technical questions?
- Configuration questions/problems?
- Technical operating problems?
- Need documentation?

Who to Contact?

The **GSM/CDMA Data Module Customer Support Center** is ready to assist you on integration issues.

Direct Customer

Use the following email address to contact customer assistance:

M2M.CustomerCare@motorola.com

Note: The support services provided by Motorola are subject to the agreement between the customer and Motorola and may be at an additional charge to the customer. Motorola will inform the customer in advance of any such charge.

Indirect Customer

Send requests to your distributor and not to Motorola help desk.

Required Query Information

Every new call/problem report, directly from a Direct Customer or from a distributor, should be directed to the help desk email address noted above in “**Who to Contact?**”. It is recommended to report each individual issue in a separate email. The following information is required when reporting a problem:

- Customer name and address
- Customer contact information for this request, including:
 - Name
 - Telephone
 - Fax number

- Mobile number
- Email address
- Product name (W24)
- Software version of the unit (ATI3 command) or model number
- PCB version (located on the PCB near the RF connector)
- Severity of the problem
- Problem description, including:
 - Operator name
 - Type of SIM card (for example, Test, Pre-paid, or 5v/3v/1.8v)
 - Setup Configuration (such as Developer Board, handset, host, connections, and so on)
 - Detailed scenario from startup
 - Log of all the commands and the responses, beginning from startup
- Answers to the following questions:
 - Was the same scenario tested on the Developer Board and the PC to reproduce the problem?
 - How many units do you have, and how many of them have this problem?
 - How often does the problem recur?

In addition to the information requested above, when a W24 is used, send the following AT+i commands and the HyperTerminal log with the responses:

- **TBD**

Motorola Workflow

The help desk uses the following workflow when responding to new calls:

1. Each new call is registered in the help desk data base.
2. The help desk immediately notifies the customer with the help desk system record number for each issue.
3. A champion is assigned to be responsible for the new call, from arrival to closing.
4. During this time, the champion updates the help desk system with the progress of the resolution process.
5. The champion is the contact to the customer and the engineering team, and coordinates activities that are required to solve the problem.

Service Centers

Motorola Electronics Taiwan PCS

11F, No, 296, Sec. 4, Jen-Ai Road
Taipei, 106, Taiwan, R.O.C

Motorola GmbH

Am Sophienhof 10
D-24941 Flensburg
Germany

Motorola Communications ISRAEL Ltd.

Service Operation
Attention: Shukrun Ofer
3 Kremetski Street
Tel Aviv, Israel 67899
Telephone: (972) 3 5658829

JNB Electronics Pty Ltd.

347 Settlement Road, Thomastown
VIC 3074
Australia

Flextronics

Transportation group leader
Zalaegerszeg Industrial Park 1 PCC
Building 1 PCC Posta u. 63
H-8900 Zalaegerszeg
Hungary

BGH do Brasil Comunicações e Serviços Ltda.

Al Ceci, 534 - Galpão 3
Barueri - SP - Brazil
Tel: 54 11 4309 2046

FeiHongDaLi Telecommunications Technology Co.Ltd.,TianjinSHI

B-6F JuFu Yuan Building
XinKai Road, Hedong District,
Tianjin 300011
China

Field service should be coordinated with the Service Manager in Motorola using the following email address: **n2csfs01@motorola.com**

Troubleshooting

Table 3-1 lists problems that may occur during board operation, and describes how to resolve them. If the problem persists, please contact your Motorola representative.

Table 3-1: Troubleshooting

Problem	Indication	Action
Power		
Developer board does not power up	Power LED does not light	Check the power source connection. If using an external DC power source, verify that the supply is within the limits of 3.3 V to 4.2 V. Verify that the board power switch (S200) is on. Check the source jumper (P203 or P204) position. Verify that the EVB jumper (P201) is present.
The W24 does not power up or does not communicate	The Developer Board on/off LED doesn't light or lights for a short period	Check the W24 connection to the Developer Board. Verify that the UUT jumper (P203 or P204) is present. Depress the W24 on/off pushbutton for a longer period.
	The Developer Board on/off LED lights up automatically when power is applied	Contact your Motorola representative.
	The Developer Board on/off LED blinks	
High current consumption	The resetable fuse is turned on	Check the polarity of the DC power inputs. Verify that only one optional power source is connected.
Wi-Fi Reception		
No Wi-Fi reception available	The W24 unit searches unsuccessfully for network	If using an external DC power source, verify that the supply is within the limits of 3.3 V to 4.2 V. Fasten the W24 to the board with the supplied screws. Check the Wi-Fi antenna connection. Fasten the Wi-Fi antenna connections.
Serial Communications		
The USB port does not work with the PC	The PC does not recognize connection	Make sure USB is connected to J380 and not to J210. Verify that W24 drivers are properly installed.
The RS232 port does not work with the PC	The PC does not communicate	Check the serial cable connection to the PC. Verify that the PC port settings comply with the W24 defaults.
	Incorrect RS232 LEDs are lit	Contact your Motorola representative.
Data logger does not operate	No activity in the application window	Check the serial cable connection to the PC. Verify that the PC port settings comply with the W24 defaults. Check the LOGGER switch (S140) setting.
General		

Table 3-1: Troubleshooting (Cont.)

Problem	Indication	Action
The LEDs do not light	The LEDs are not lit	Contact your Motorola representative.
The W24 does not enter sleep mode	The W24 always active	Verify that the WAKEUP option switch is off.

Appendix A: Parts List

Developer Board Parts list

Table A-1 is a parts list for the W24 Developer's Kit. Schematic diagrams for the kit are provided in "Appendix B: Schematics and Placement Diagrams" .

Table A-1: Developer Board Parts List

Reference Symbol	Description
Resistors	
R131	100Ω 1%
R155, R168	475Ω 1%
R163, R156, R164, R157, R165, R158 R166, R169	2.49Ω 1%
R739, R171, R159	10KΩ 1%
R431, R433, R434, R430	20KΩ 1%
R347, R167, C142	100KΩ 1%
R138	102KΩ 1%
R254	110KΩ 1%
R234	130KΩ 1%
R235, R173	200KΩ 1%
R233	301KΩ 1%
R220, R240	332KΩ 1%
R252	340KΩ 1%
R174	442KΩ 1%
R424, R417, R427, R450, R451, R437, R460, C412, R141, R161, R409, R410, R413, R422, R343, R130	0.0
R132	56Ω 5%
R440	68Ω 5%

Table A-1: Developer Board Parts List (Cont.)

Reference Symbol	Description
Resistors, cont.	
R723, R725, R745, R747	180Ω 5%
R703	270Ω 5%
R710, R705, R707, R709, R731, R718, R733, R727, R735, R729, R737, R760, R753, R761, R762, R763, R749, R764, R765, R780, R766, R781, R767	300Ω 5%
R203	390Ω 5%
R738, R120, R121, R122, R202, R123, R124, R204, R125, R126, R127, R170, R175, R176	1KΩ 5%
R416	1.5KΩ 5%
R412	2.2KΩ 5%
R200, R201, R236, R181	4.7KΩ 5%
R419, R441, R464, R237, R341, R414	10KΩ 5%
R418, R411	20KΩ 5%
R206	100Ω 1%
Capacitors	
C207, C215, C217, C234	8.2pF
C4	2.0pF
C345, C346	12.0pF
C414	0.01uF

Table A-1: Developer Board Parts List (Cont.)

Reference Symbol	Description
Capacitors, cont.	
C174, C182	0.1uF
C430, C431, C433, C434	0.22uF
C302, C303, C304, C305, C352, C353, C354, C355, C372, C373, C374, C375	0.33uF
C5	330pF
C208	3.3pF
C151, C153, C155, C148, C157, C159, C425, C426, C427, C442, C450, C444, C447, C462, C472, C473	10pF
C781, C191, C422, C423, C416, C424, C417, C418, C435, C443, C436, C437, C445, C438, C446, C439, C461, C448, C470, C463, C449, C471, C464, C474, C475	33pF
C121, C123, C131, C125, C133, C119, C127, C128, C129, C216, C231, C218	39pF
C794	68pF
C221, C241	0.01uF
C101, C107, C136, C144, C146, C139	0.1uF
C780, C790, C791, C792, C793, C788, C789, C301, C170, C172, C410, C180, C420, C413, C341, C190, C432, C371, C453	1uF
C441	22uF
C181	1uF
C220, C222, C240, C242, C250, C252	10uF
C230, C232	47uF
C201 C202 C203 C204 C205 C206	1000uF
Inductors	
L1	3.9nH
L2, L3	12nH
L440	33nH
L151	100nH
L250	10uH

Table A-1: Developer Board Parts List (Cont.)

Reference Symbol	Description
Connectors	
P200, P201, P203, P204	Jumper 2 pin
P1 (W24)	Molex 52991-0708
P50	Samtec TMMH-120-01-S-DV-M-TR
J230	HIROSE MQ200-MO-3S(01)
P100	Samtec TMMH-135-01-SM-DV-M-TR
P2	HUBER AND SUHNER 85 SMA-50-0-144/133JH
J330, J350, J300	TYCO 5788797-1
J1 (Host)	Molex 53748-0708
J122	HIROSE FH19-13S-0.5SH(48)
J380, J210	Molex 56579-0519
J430, J480	SMK LGY2209-0101F
J440 J460	SMK LGK1509-1401FSZ
J100	FCI 7111S1615A05LF
Switches	
S160, S100, S140, S141	C&K (ITT CANNON) TDA04H0SB1
S161, S170, S120	C&K (ITT CANNON) TDA08H0SB1
S200	C&K (ITT CANNON) ET21MD1AQE
S110	C&K (ITT CANNON) EP11SD1ABE
LEDs	
D200, D701	EVERLIGHT QTLP610CRTR
D721, D722, D723, D724, D725, D726, D727, D742, D728, D743, D744, D745, D760, D761, D762, D763, D764, D765, D780, D766, D781, D767, D768, D702, D710, D703, D704	EVERLIGHT QTLP601C4TR
Transistors	
Q201, Q230	MMBT3906LT1G

Table A-1: Developer Board Parts List (Cont.)

Reference Symbol	Description
Q780, Q200, Q203	FAIRCHILD SI4463DY_NL
Diodes	
D100	INFINEON BAS52-02V
VR200	ON SEMI 1SMB5918BT3G
VR230, VR383	ON SEMI MMBZ5246BLT1G
Integrated Circuits	
U160	ON SEMI LM2904DR2G
U180, U181	ON SEMI NL7SZ18DFT2G
U190, U342, U712, U714	ON SEMI MC74VHC1G14DFT2G
U220, U240	NATIONAL LP2989AIMX-3.0 NOPB
U230	ON SEMI NCP5663DSADJR4G
U250	MAXIM MAX1722EZK+T
U330	Texas Instruments SN65C3238DBRE4
U332, U440	ON SEMI MC74HC1G08DFT2G
U340	MAXIM MAX3100EEE+T
U350, U370	Texas Instruments SN65C3223DBRE4
U352, U372	ON SEMI MC74HC1G00DFT2G
U410	FREESCALE MC145483ENR2 or WINBOND W681360RG
U420	MAXIM MAX4674ETE
U430	Texas Instruments TPA6203A1ZQVR
U708, U702, U710, U704, U706	ON SEMI MC74LCX04DTR2G

Table A-1: Developer Board Parts List (Cont.)

Reference Symbol	Description
General	
F202	Raychem SMD250F-2
M1	Motorola Antenna Contact
M10, M11, M12, M20, M13, M14, M15, M16, M17, M18, M19	Technics Metal PTE 2989813V01
M2, M3	Mac8 2SSA-3.0-S-05
RV130, RV131, RV132, RV133, RV134, RV135, RV410, RV411, RV412, RV413, RV414, RV415, RV416, RV417, RV380, RV381, RV382	TDK AVR-M1005C270MTAAB
SH400	Motorola Shield
Y340	NDK NX1255GB

Developer Board Unplaced Parts list

Table A-2 is the unplaced parts list for the W24 Developer's Kit.

Table A-2: Developer Board Unplaced Parts List

Reference Symbol
Resistors
R133, R439, R425 R420, R100, R150, R180, R182, R183, R230, R452, R140, R177, R178, R415
Capacitors
C2, C102, C103, C104, C105, C106, C108, C109, C110, C111, C112, C113, C114, C115, C116, C117, C118, C120, C122, C124, C126, C130, C132, C134, C135, C137, C138, C140, C141, C143, C147, C149, C150, C152, C154, C156, C158, C160, C145, C411, C100, C176, C415
Connectors
J200, J201
Inductors
L150

Appendix B: Schematics and Placement Diagrams

The following schematics and placement diagrams are provided on the pages that follow:

- Developer Board Top-Level Design
- Diagnostics
- Power
- Serial Interface
- Audio Interface
- LEDs
- Developer Board Top Layout
- Developer Board Bottom Layout

G24 XCVR DEVELOPER BOARD

FCN5540B
8488899V01
Revision: P2

ISSUE	RELEASE	DATE	APVD
O	XXXXX	XX XX	XXXX
A	XXXXX	XX XX	XXXX
B	XXXXX	XX XX	XXXX
C	XXXXX	XX XX	XXXX
D	XXXXX	XX XX	XXXX

G24 70 PIN CONNECTOR (SOCKET)

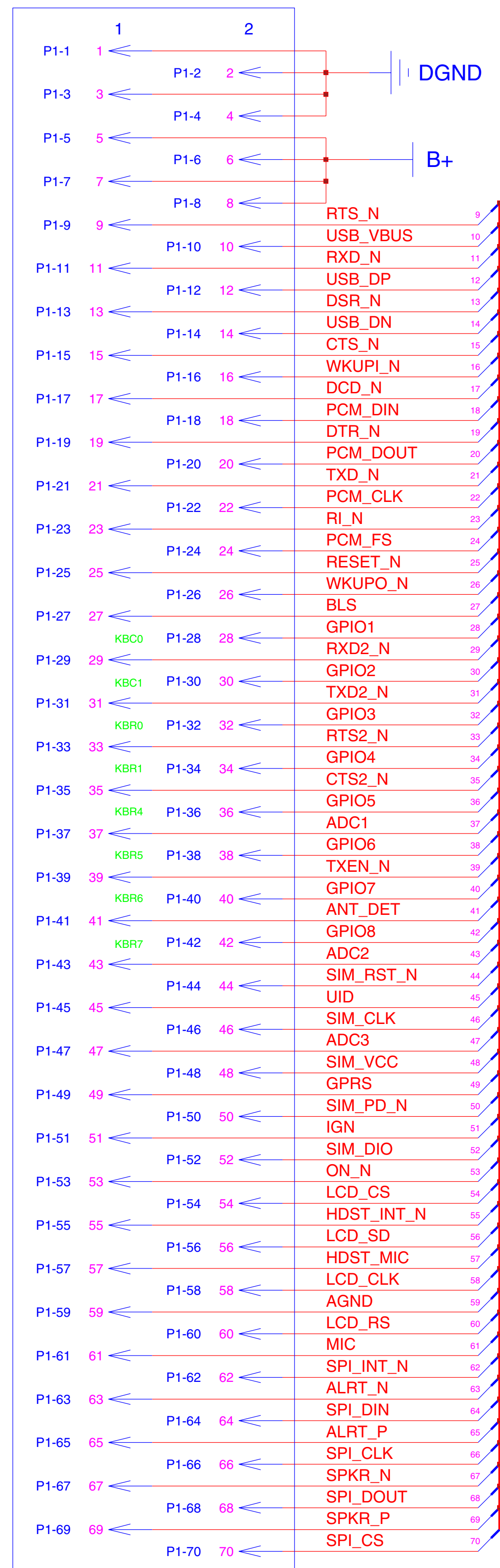

DIAGNOSTIC + CLI DISPLAY REF# 100-199

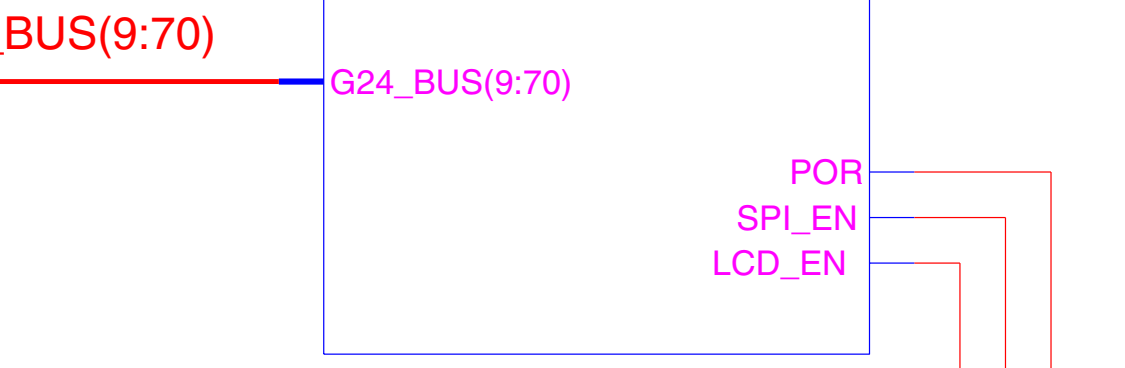

SERIAL REF# 300-399

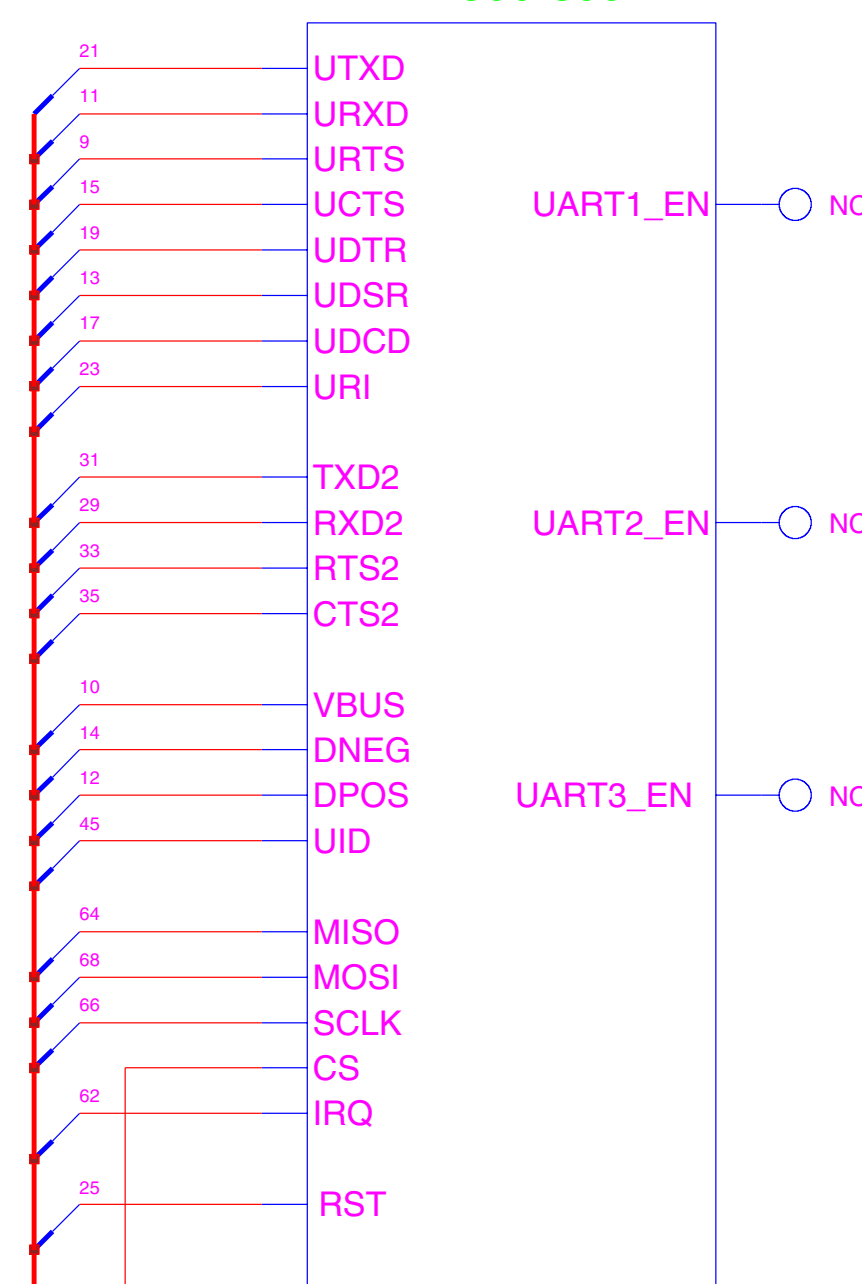

AUDIO REF# 400-499

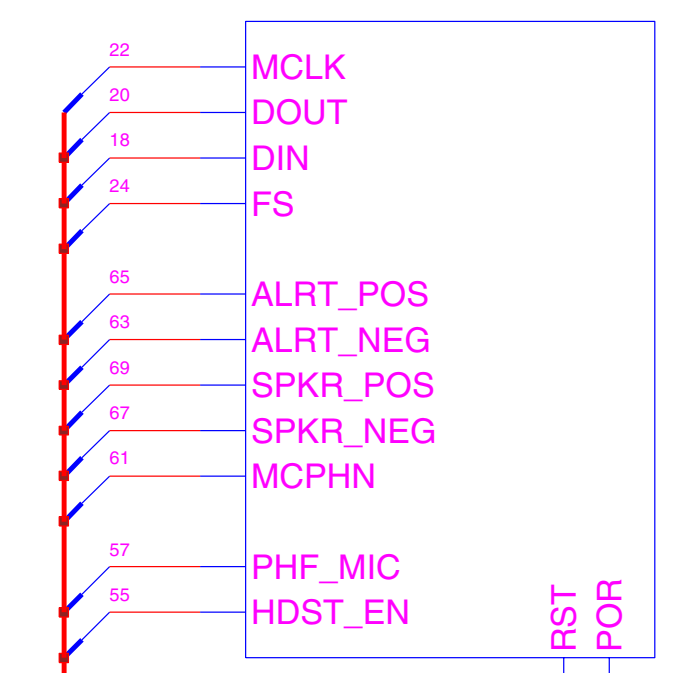

POWER REF# 200-299

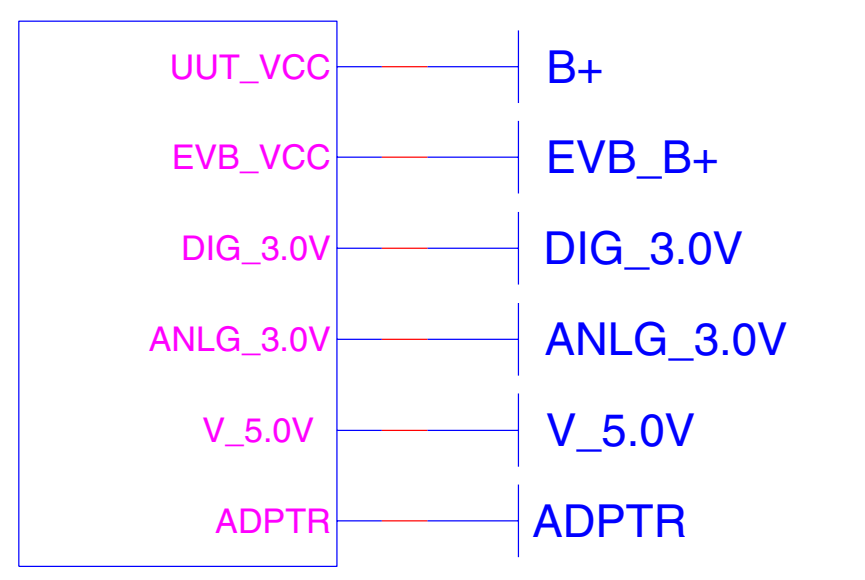

LEDs REF# 700-799

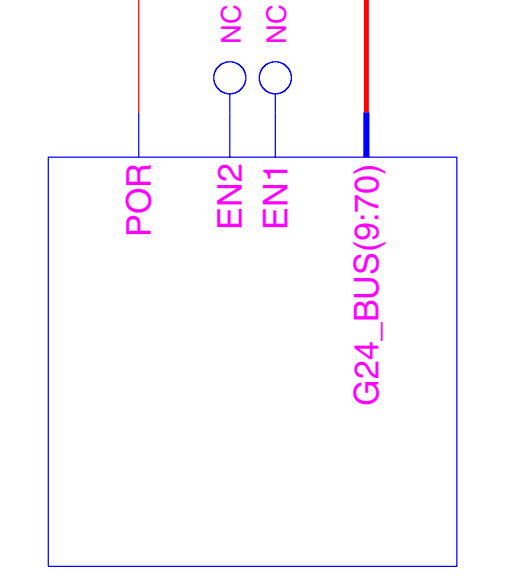

RF ANTENNA

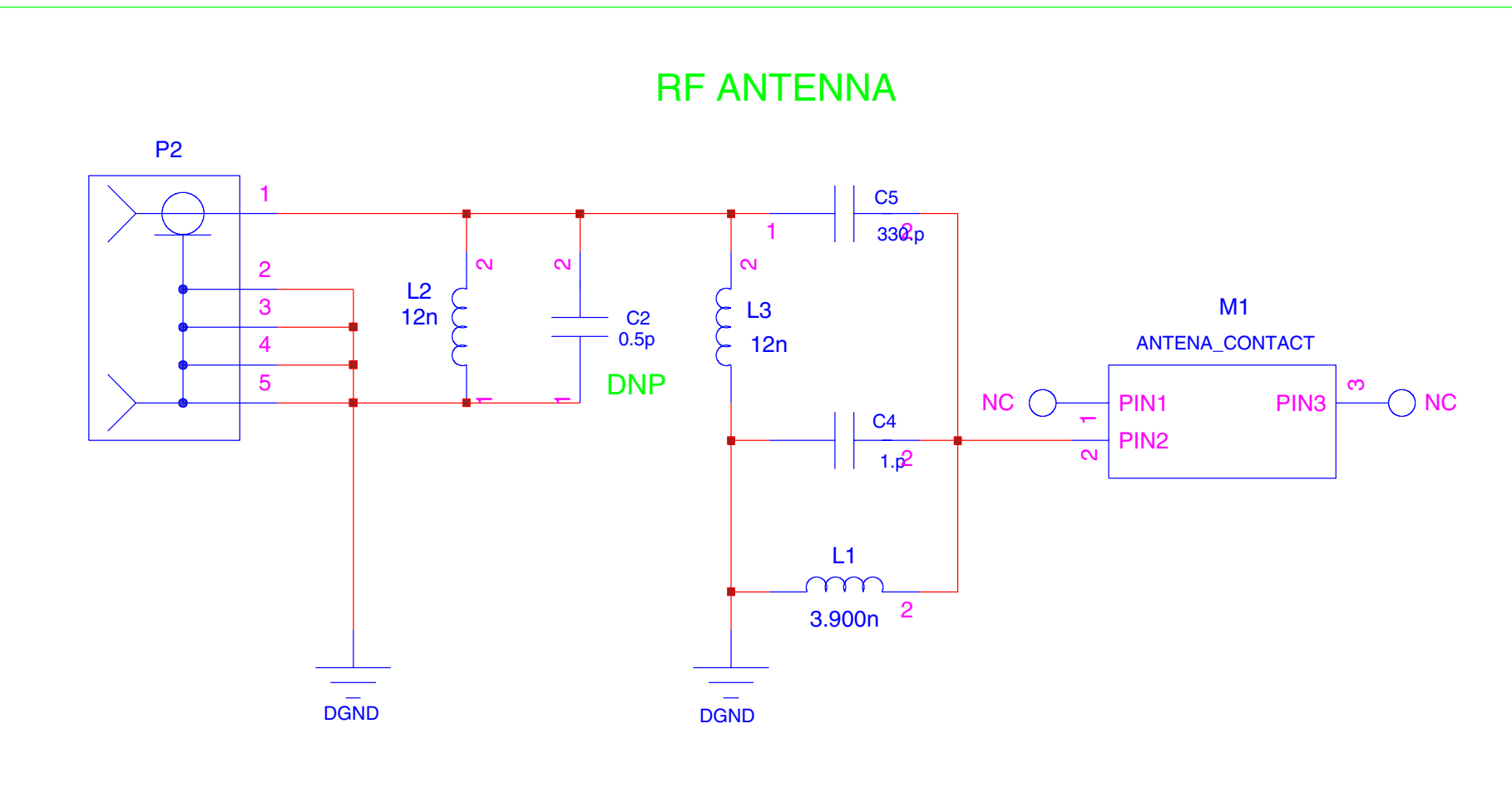

GND TEST POINTS

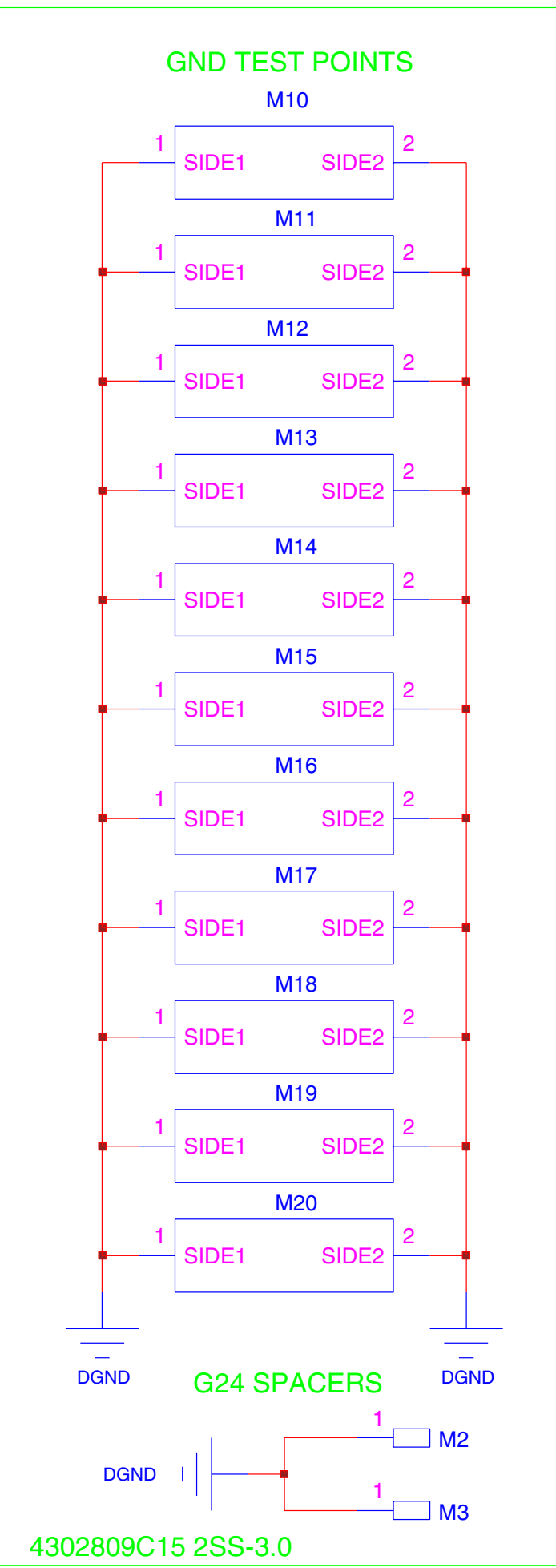

HOST 70 PIN CONNECTOR (PLUG)

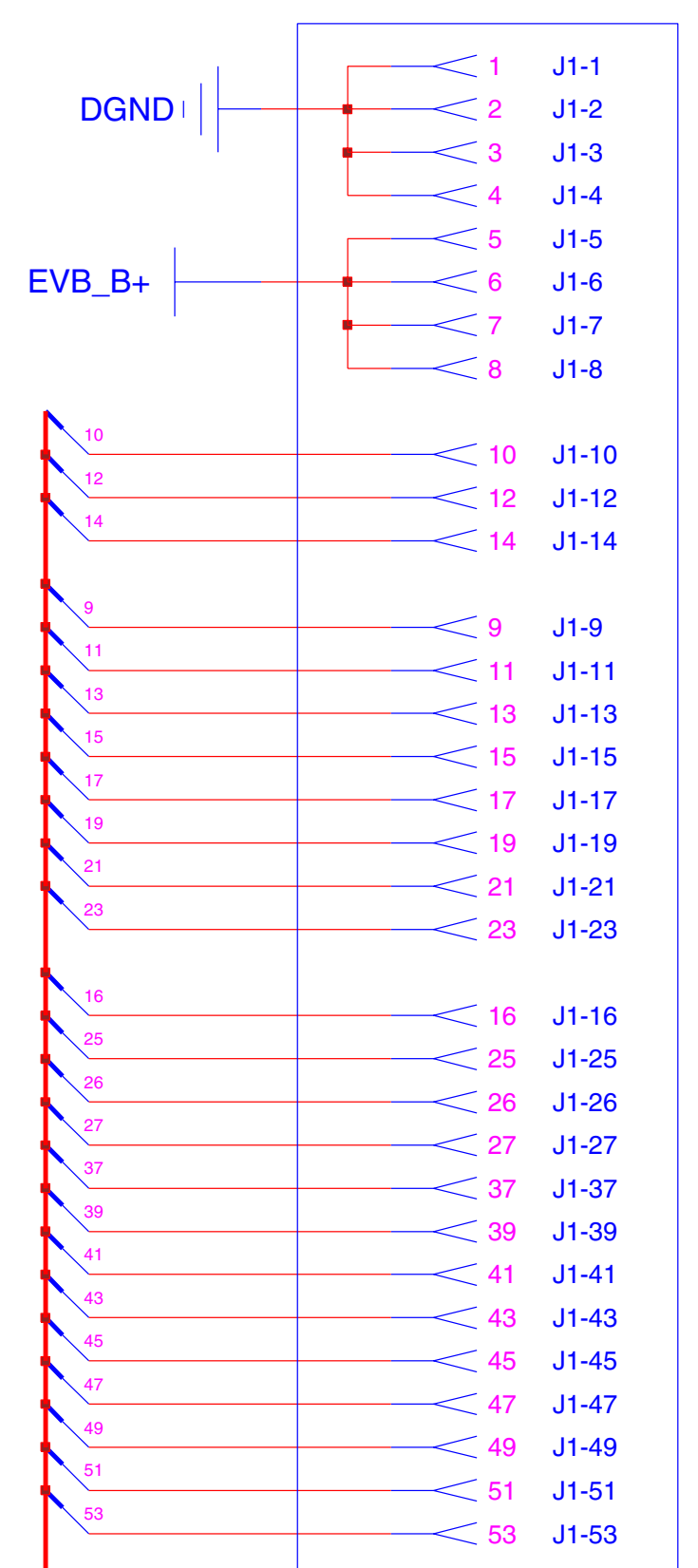

HOST 40 PIN CONNECTOR (PLUG)

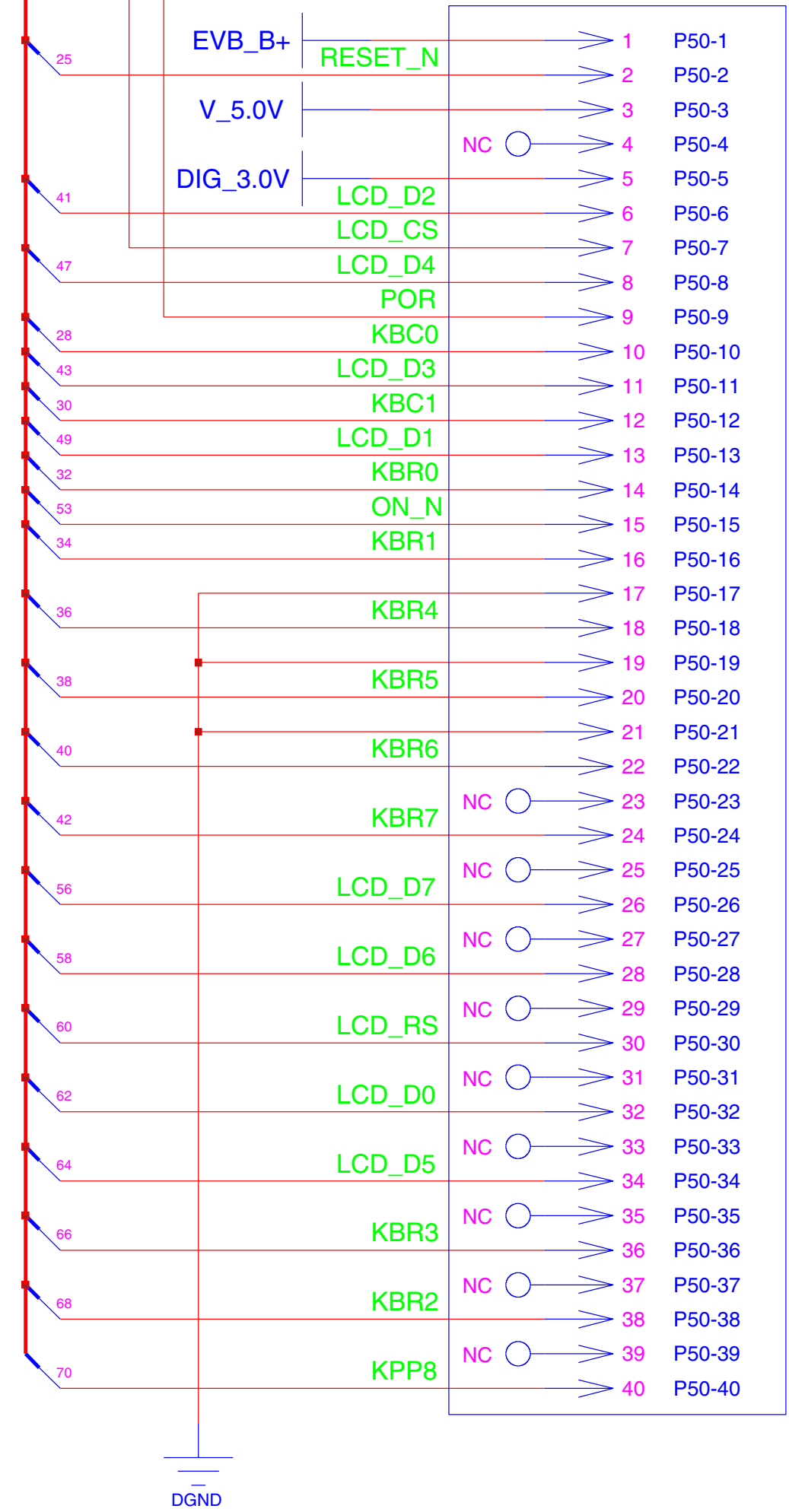

REF# 000-099



PROJ. G24 DEVELOPER BOARD

DESCRIPTION: KIT NO. XXX-XXXXX NAME TOP PCB_NO: XXXX

DRAWN: XXXX, XX/XX/XX CHECKED: XXXX, XX/XX/XX

APPROVED: XXXX, XX/XX/XX RELEASED: XXXX, XX/XX/XX

X X D X X X X X G X X - X SHEET OR X

1. DRAWING GENERATED BY COMPUTER.
2. MOTOROLA CONFIDENTIAL PROPRIETARY !!

G24 XCVR DEVELOPER BOARD DIAGNOSTICS

DIAGNOSTICS 70 PIN CONNECTOR (HEADER)

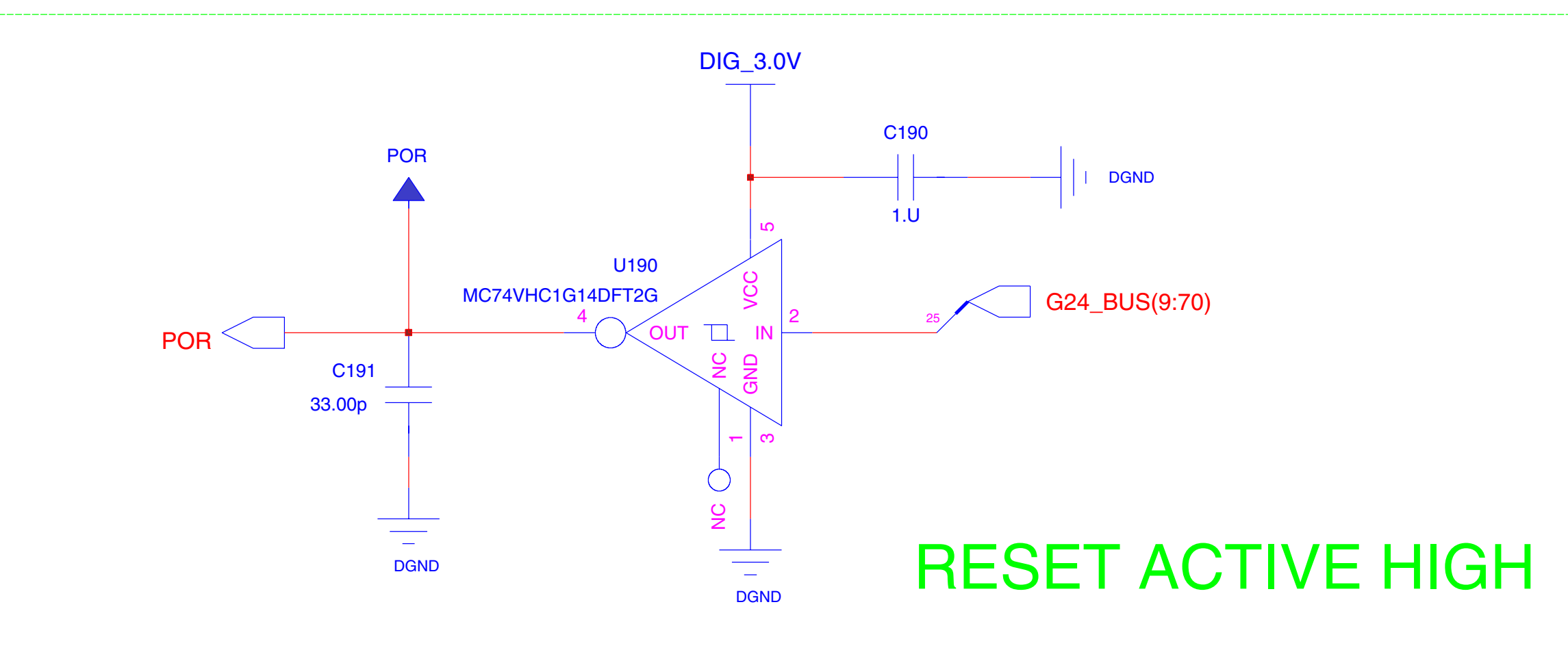
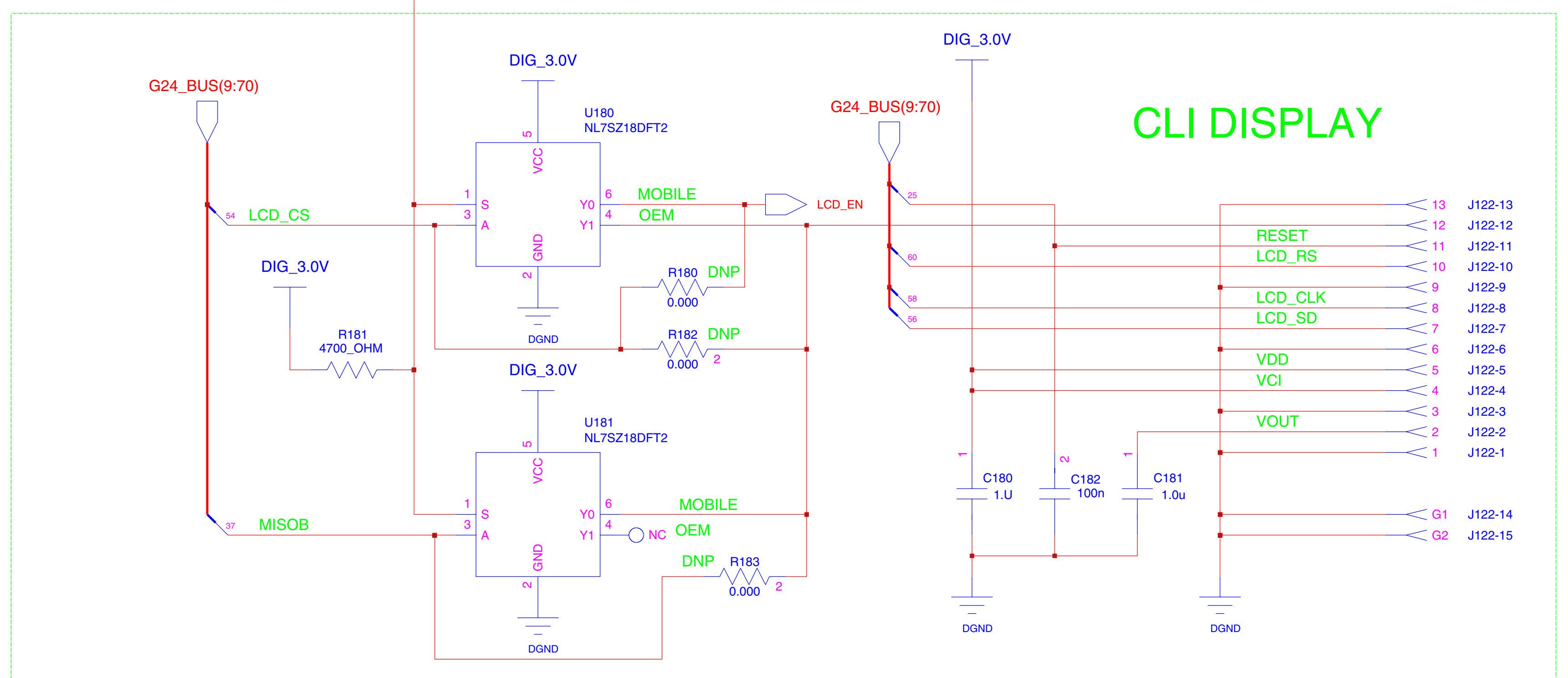
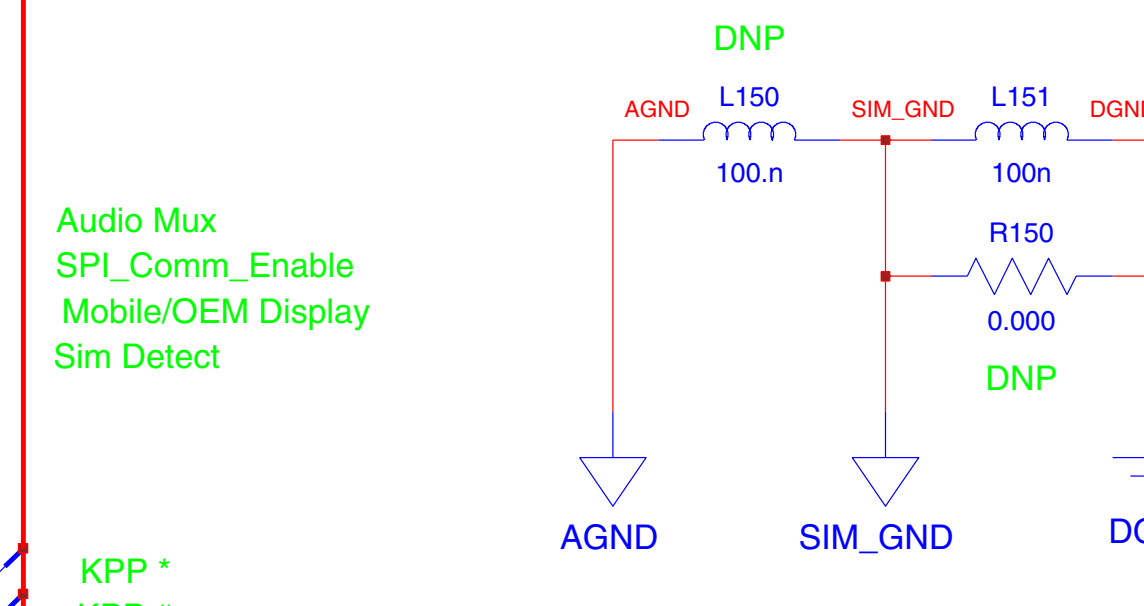
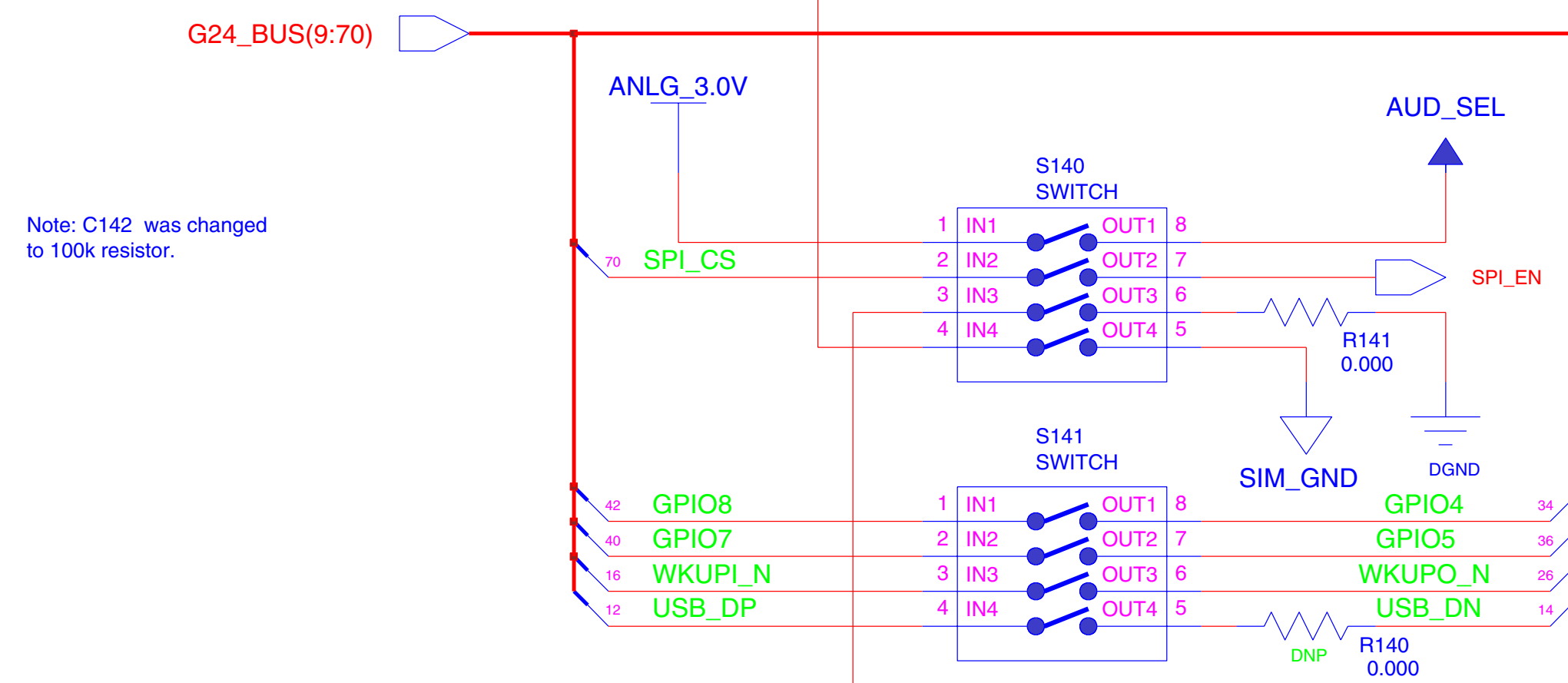
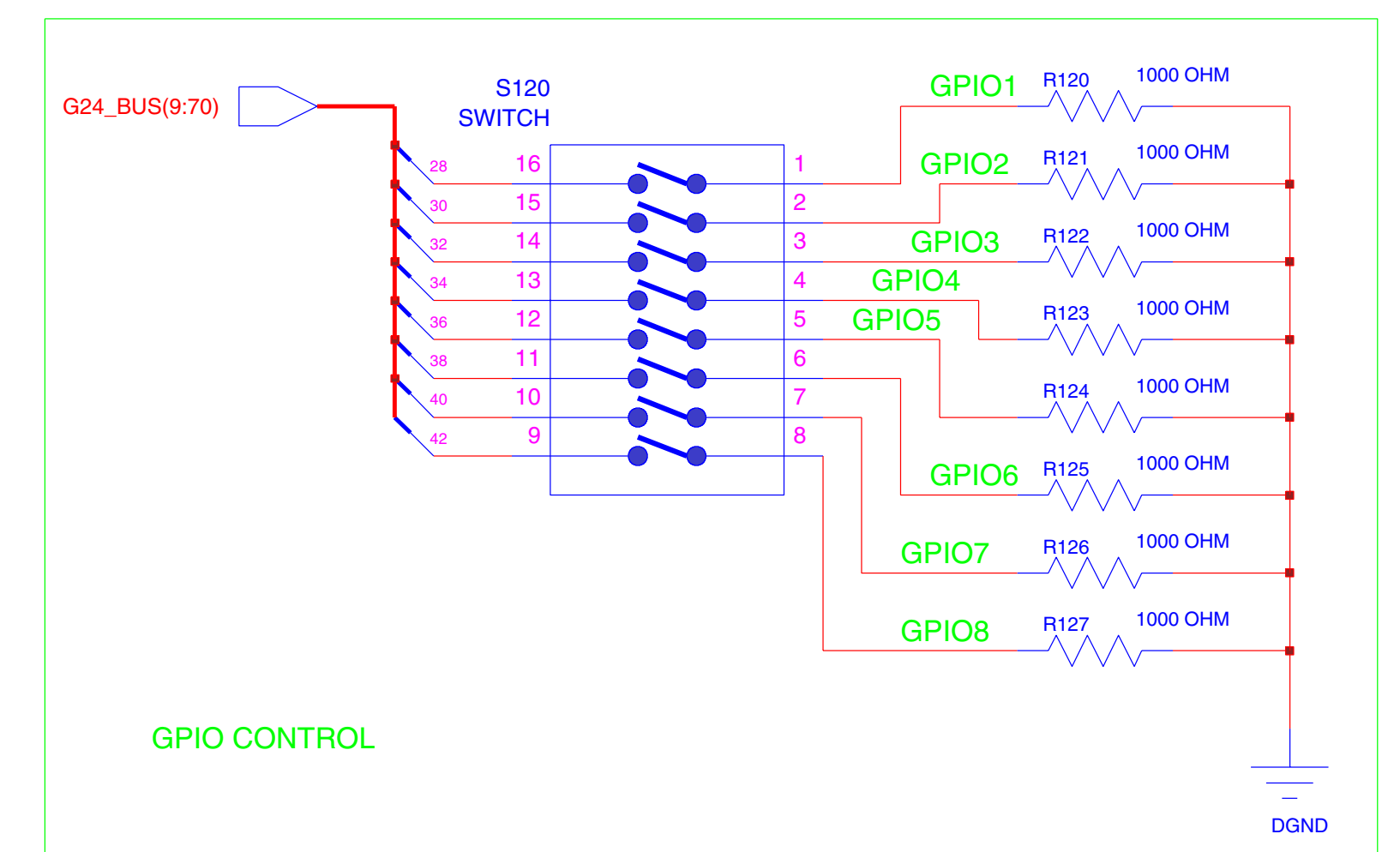
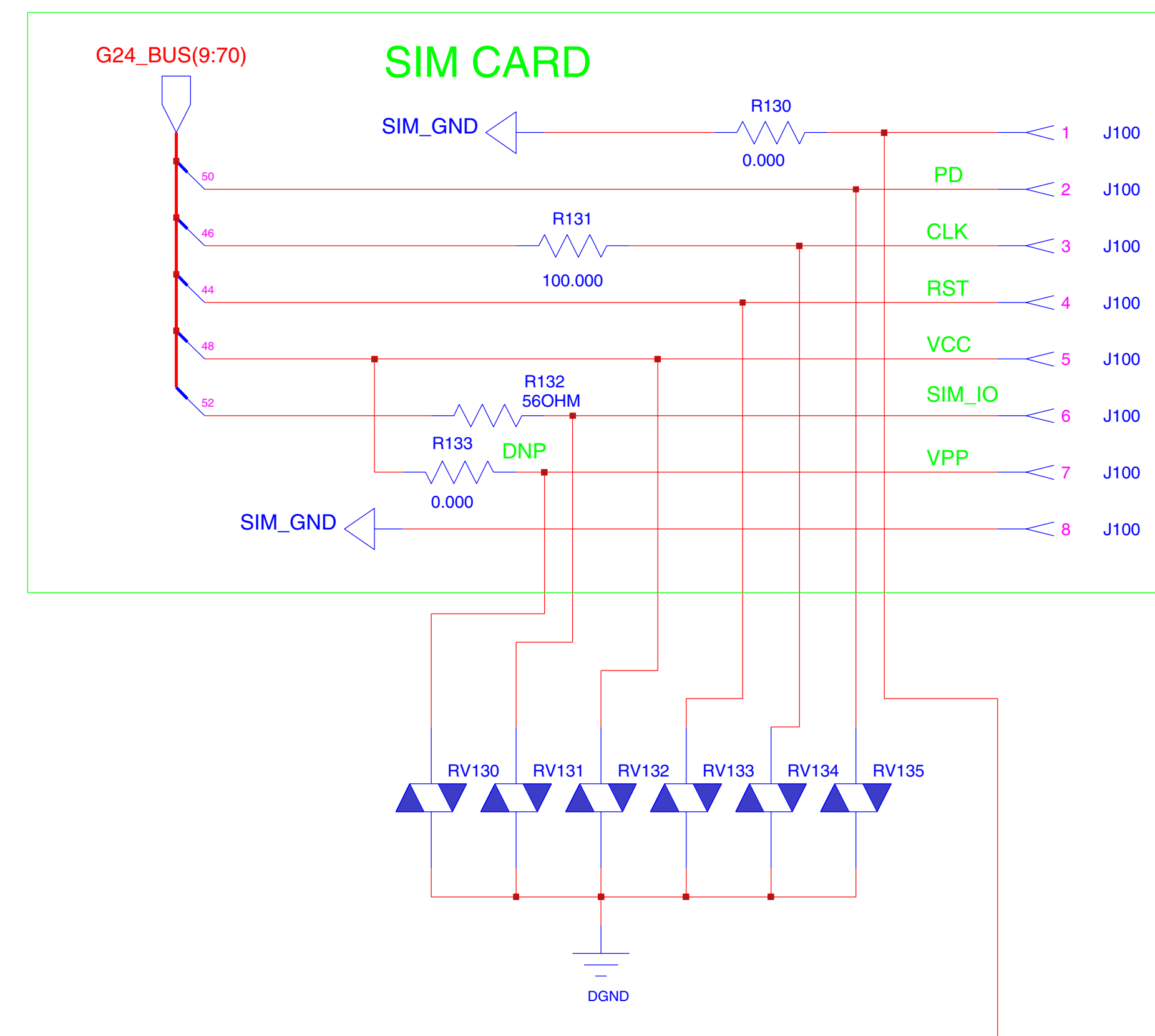
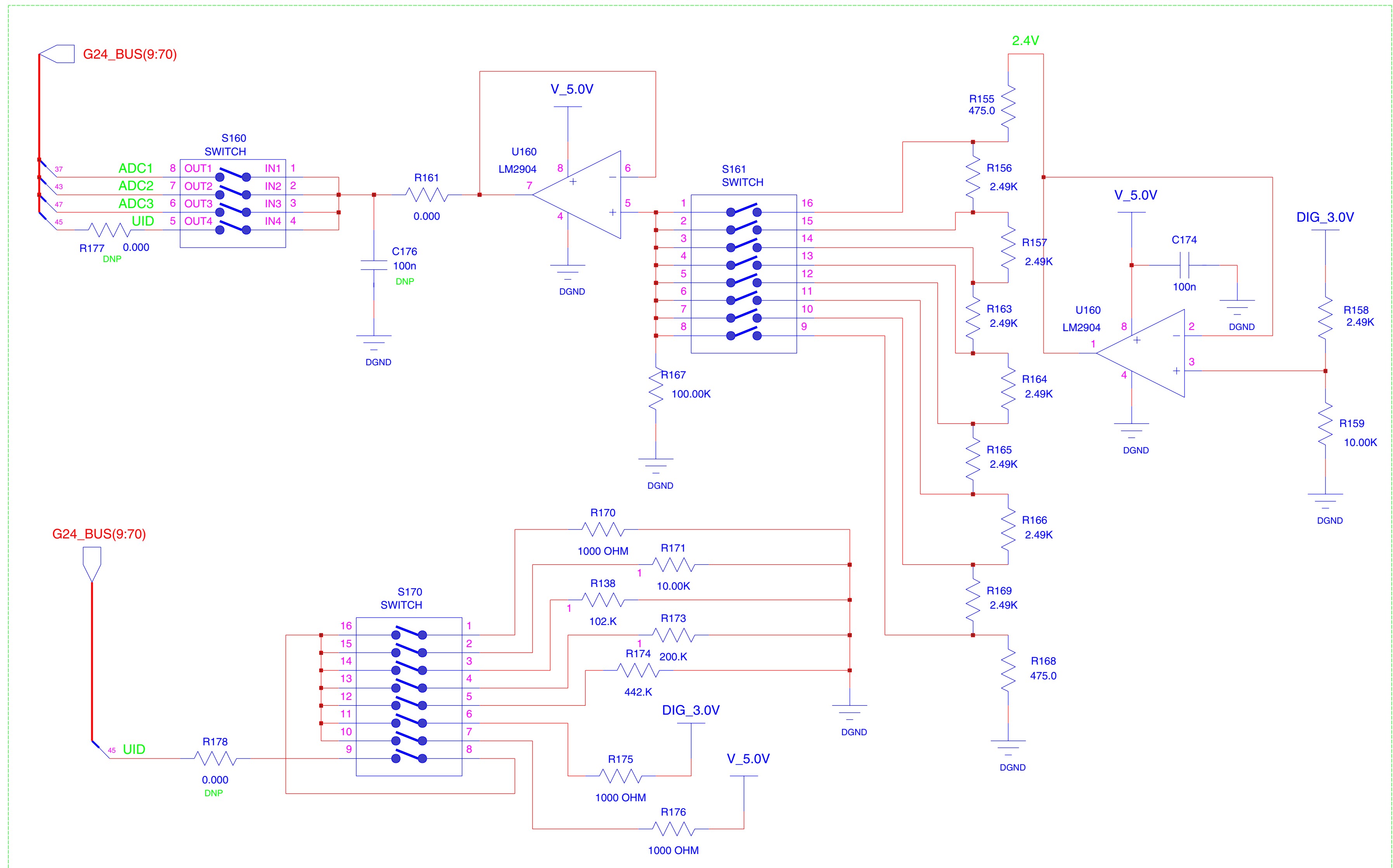
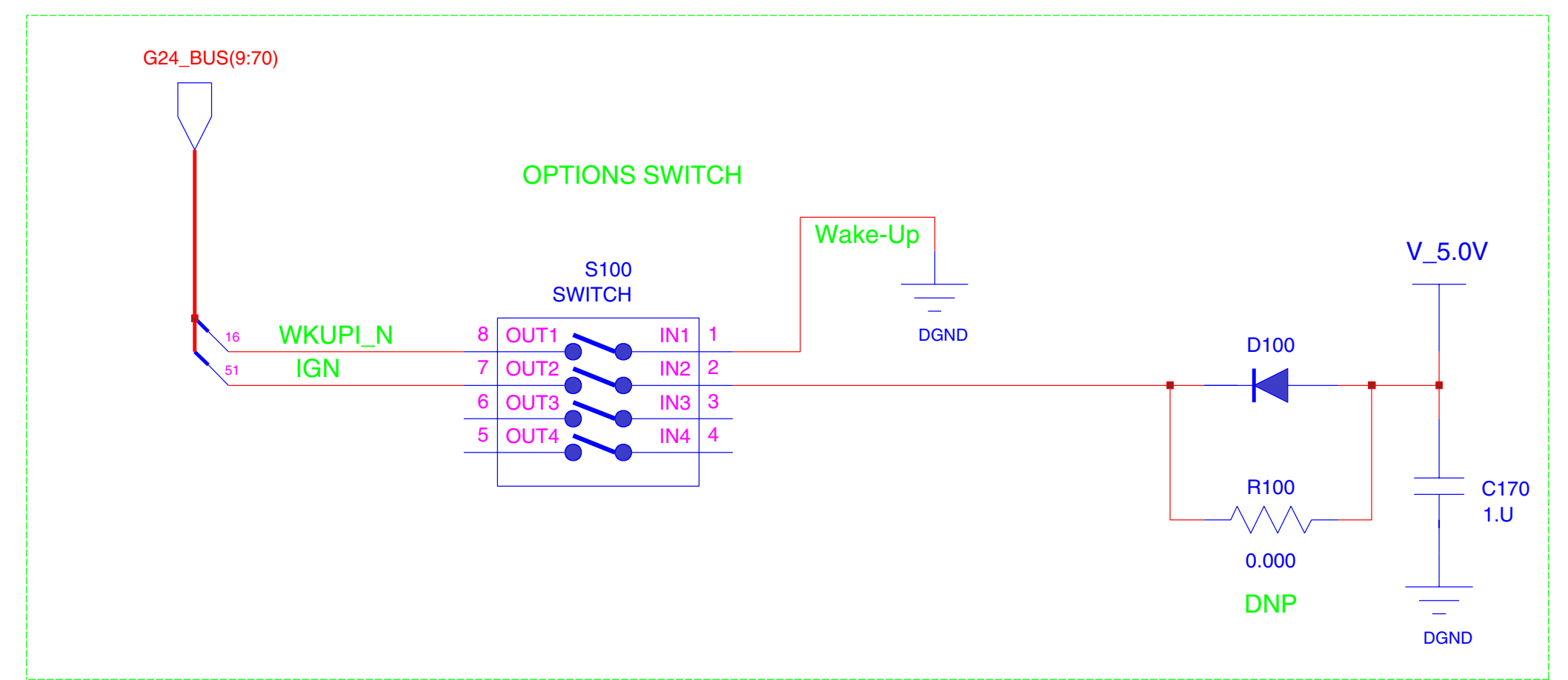
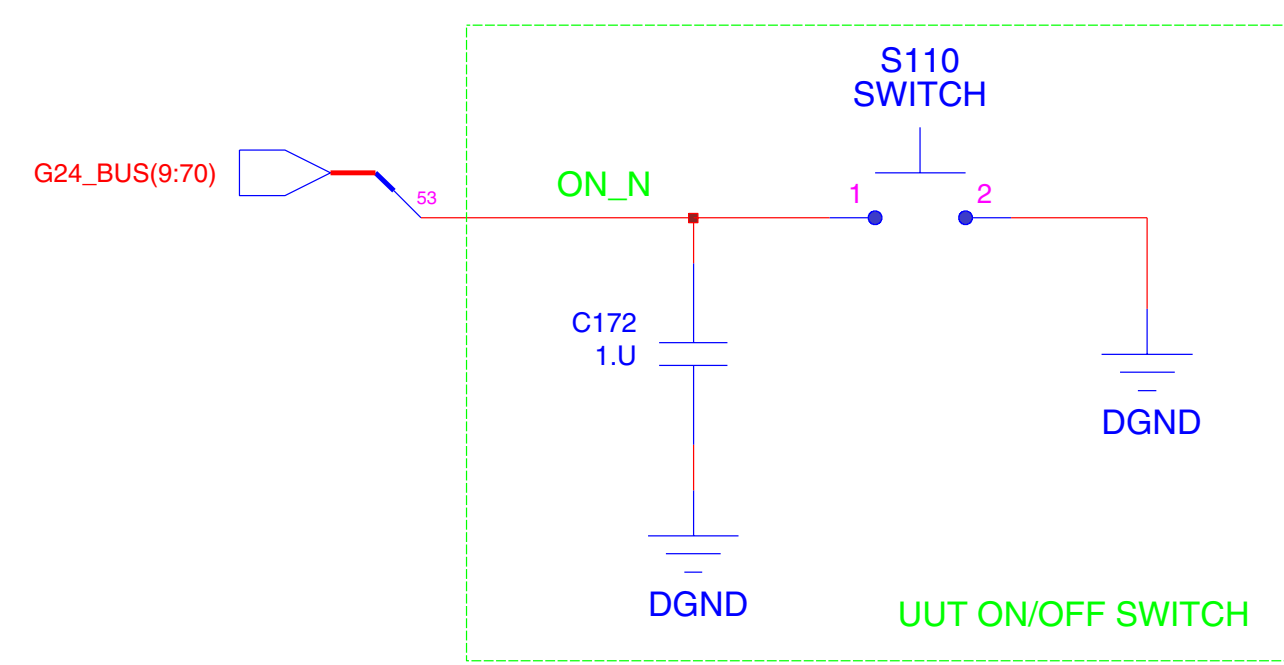
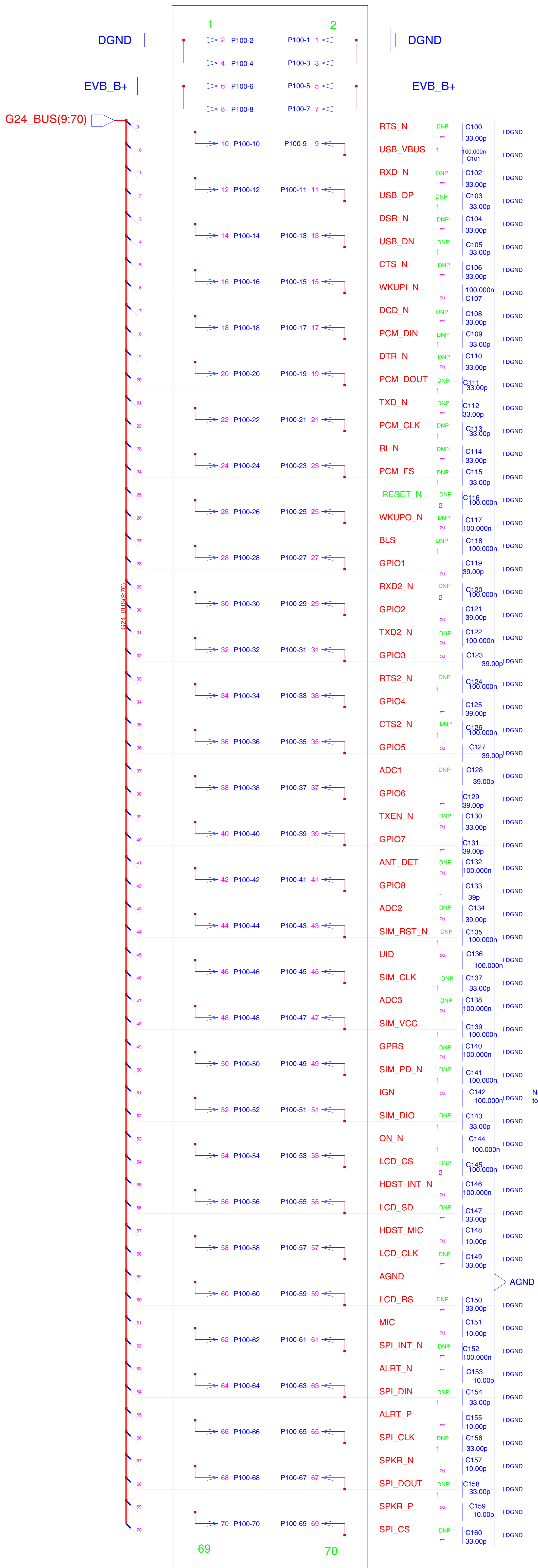

REF# 100-199



PROJ. G24 DEVELOPER BOARD					
DESCRIPTION:		NAME		PCB_NO:	
KIT NO. XXX-XXXX		DIAGNOSTIC INTERFACE		XXXX	
DRAWN	XXXX	XX/XX/XX	CHECKED	XXXX	XX/XX/XX
APPROVED	XXXX	XX/XX/XX	RELEASED	XXXX	XX/XX/XX
X	X	D	X	X	X
X	X	X	X	G	X
X	X	X	X	-	X
SHEET				OK	X

G24 XCVR DEVELOPER BOARD AUDIO

ISSUE	RELEASE	DATE	APVD
O	XXXXX	XX XX	XXXX
A	XXXXX	XX XX	XXXX
B	XXXXX	XX XX	XXXX
C	XXXXX	XX XX	XXXX
D	XXXXX	XX XX	XXXX

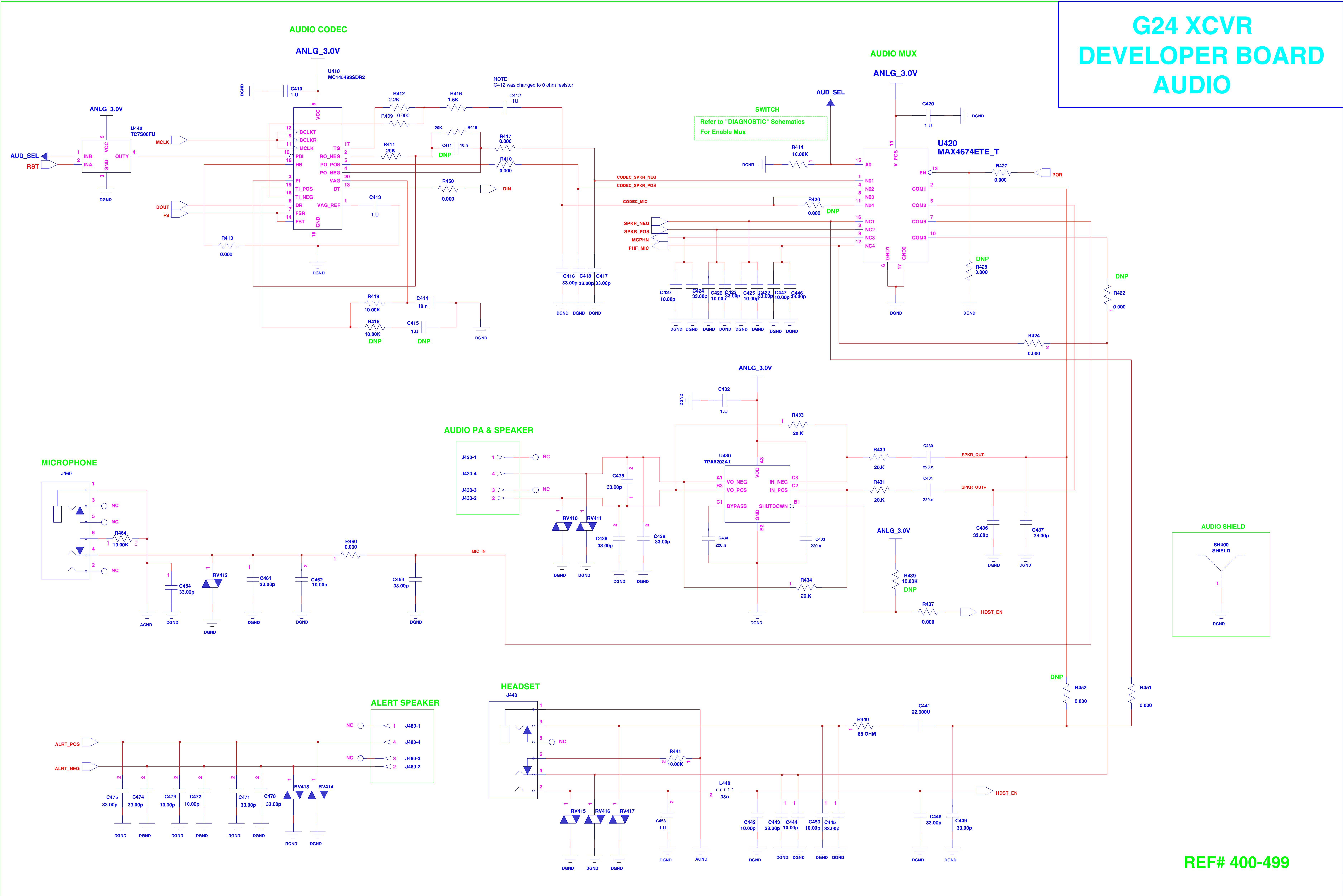

REF# 400-499



PROJ. G24 DEVELOPER BOARD

DESCRIPTION: KIT NO. XXX-XXXXX NAME AUDIO PCB_NO: XXXX

DRAWN	XXXX	XX/XX/XX	CHECKED	XXXX	XX/XX/XX
-------	------	----------	---------	------	----------

APPROVED	XXXX	XX/XX/XX	RELEASED	XXXX	XX/XX/XX
----------	------	----------	----------	------	----------

X	X	D	X	X	X	X	X	G	X	X	-	X	SHEET	OR	X
---	---	---	---	---	---	---	---	---	---	---	---	---	-------	----	---

1. DRAWING GENERATED BY COMPUTER.
2. MOTOROLA CONFIDENTIAL PROPRIETARY !!

G24 XCVR DEVELOPER BOARD LEDs

ISSUE	RELEASE	DATE	APVD
O	XXXXX	XX XX	XXXX
A	XXXXX	XX XX	XXXX
B	XXXXX	XX XX	XXXX
C	XXXXX	XX XX	XXXX
D	XXXXX	XX XX	XXXX

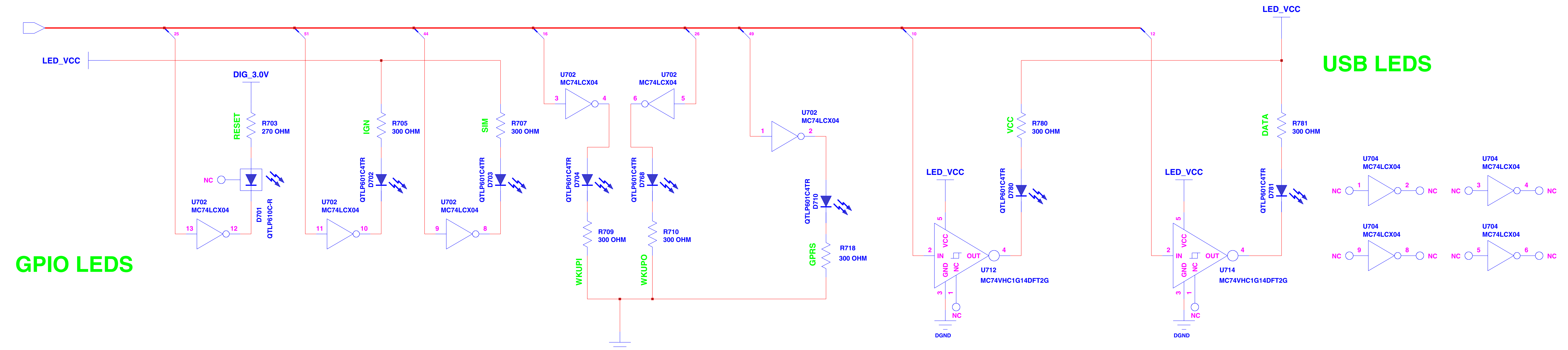
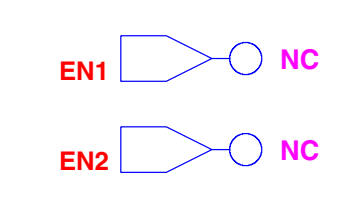

USB LEDs

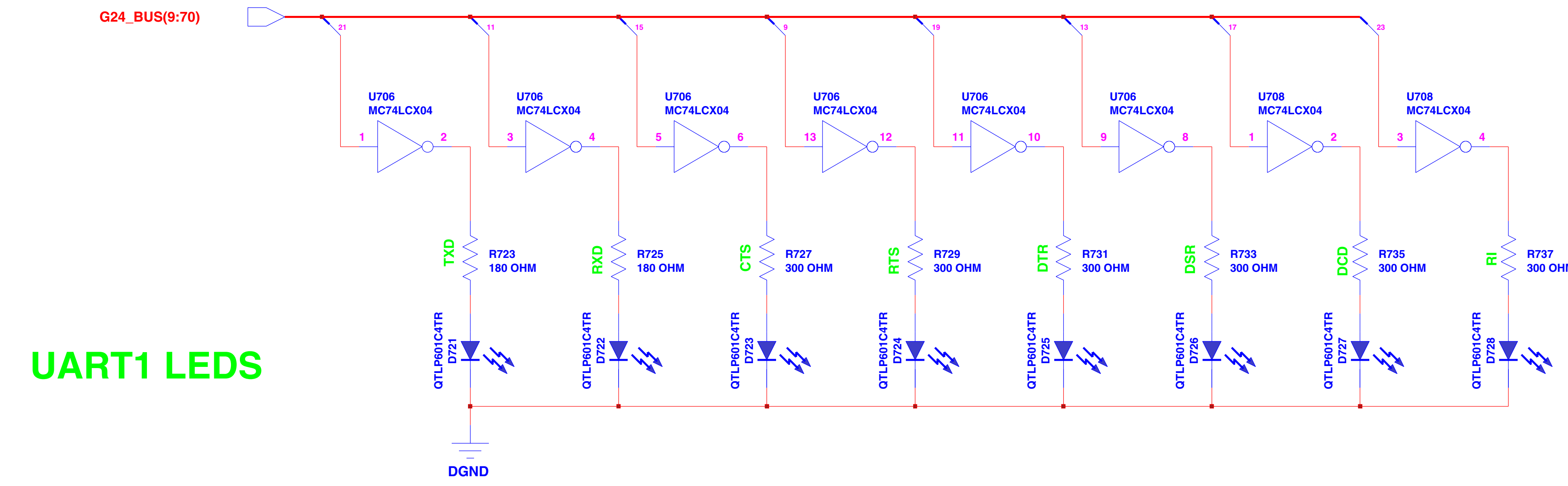
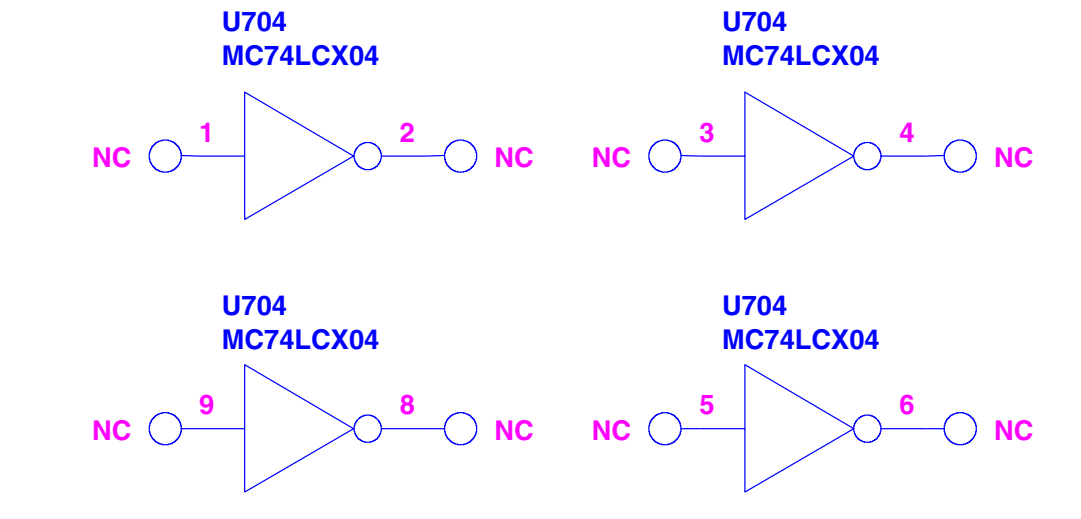

LED SUPPLY

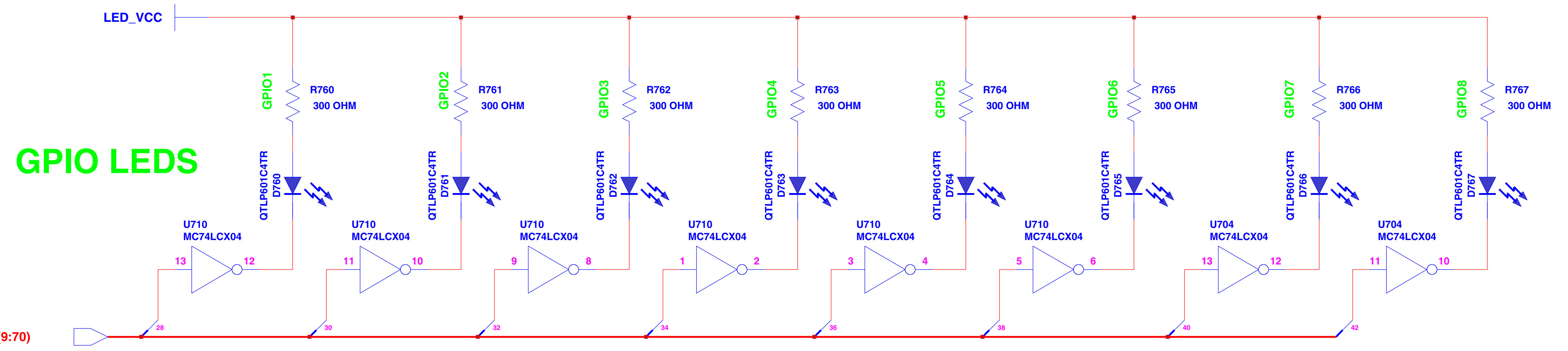
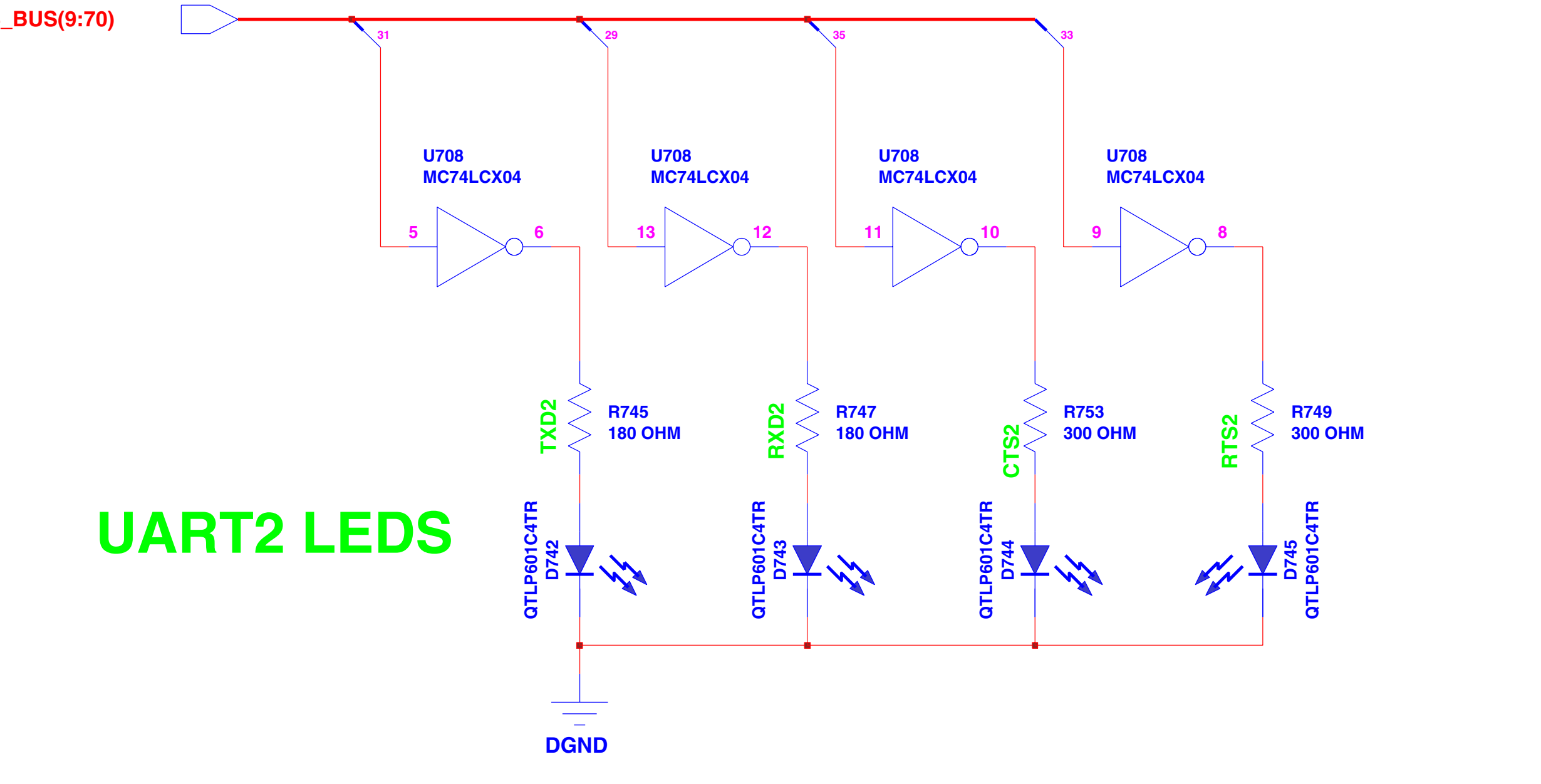
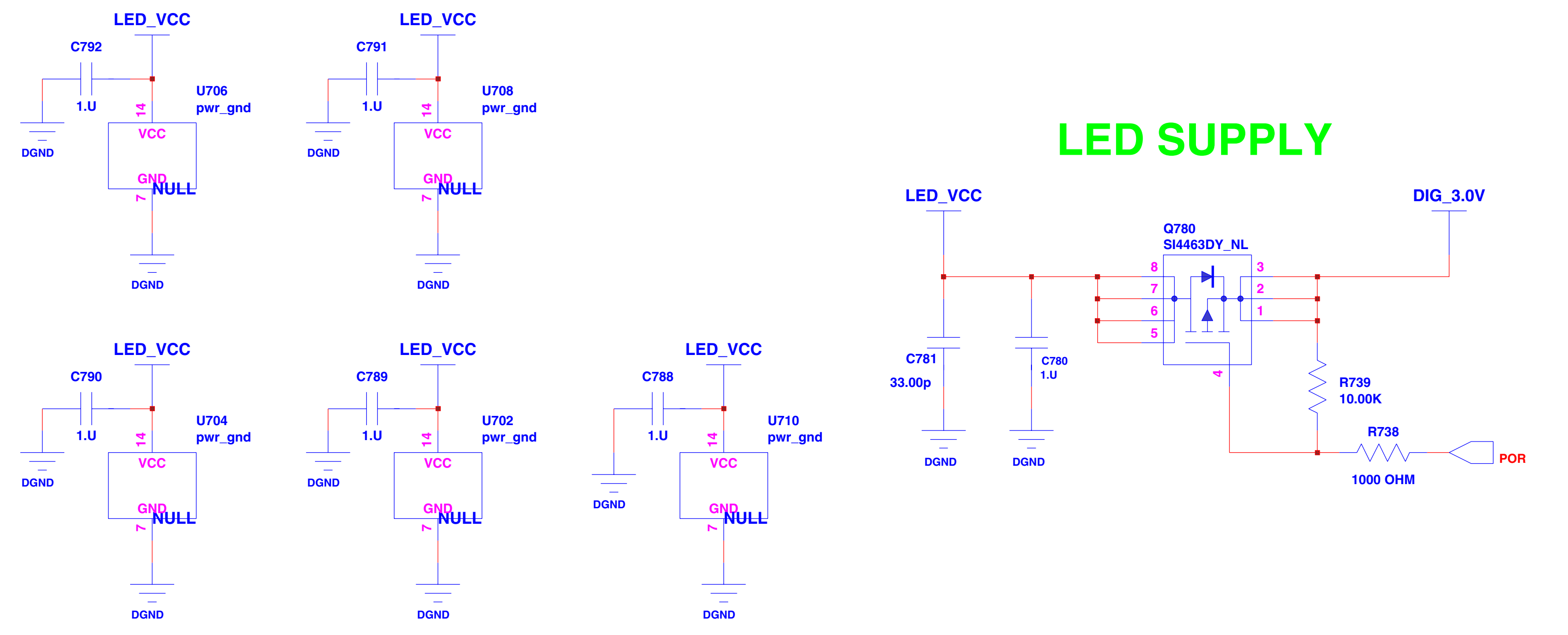

REF# 700-799



PROJ. G24 DEVELOPER BOARD

DESCRIPTION: KIT NO. XXX-XXXX NAME LEDES PCB_NO: XXXX

DRAWN XXXX XX/XX/XX CHECKED XXXX XX/XX/XX

APPROVED XXXX XX/XX/XX RELEASED XXXX XX/XX/XX

X X D X X X X X G X X - X SHEET OR X

1. DRAWING GENERATED BY COMPUTER.
2. MOTOROLA CONFIDENTIAL PROPRIETARY !!

Top Side Components View

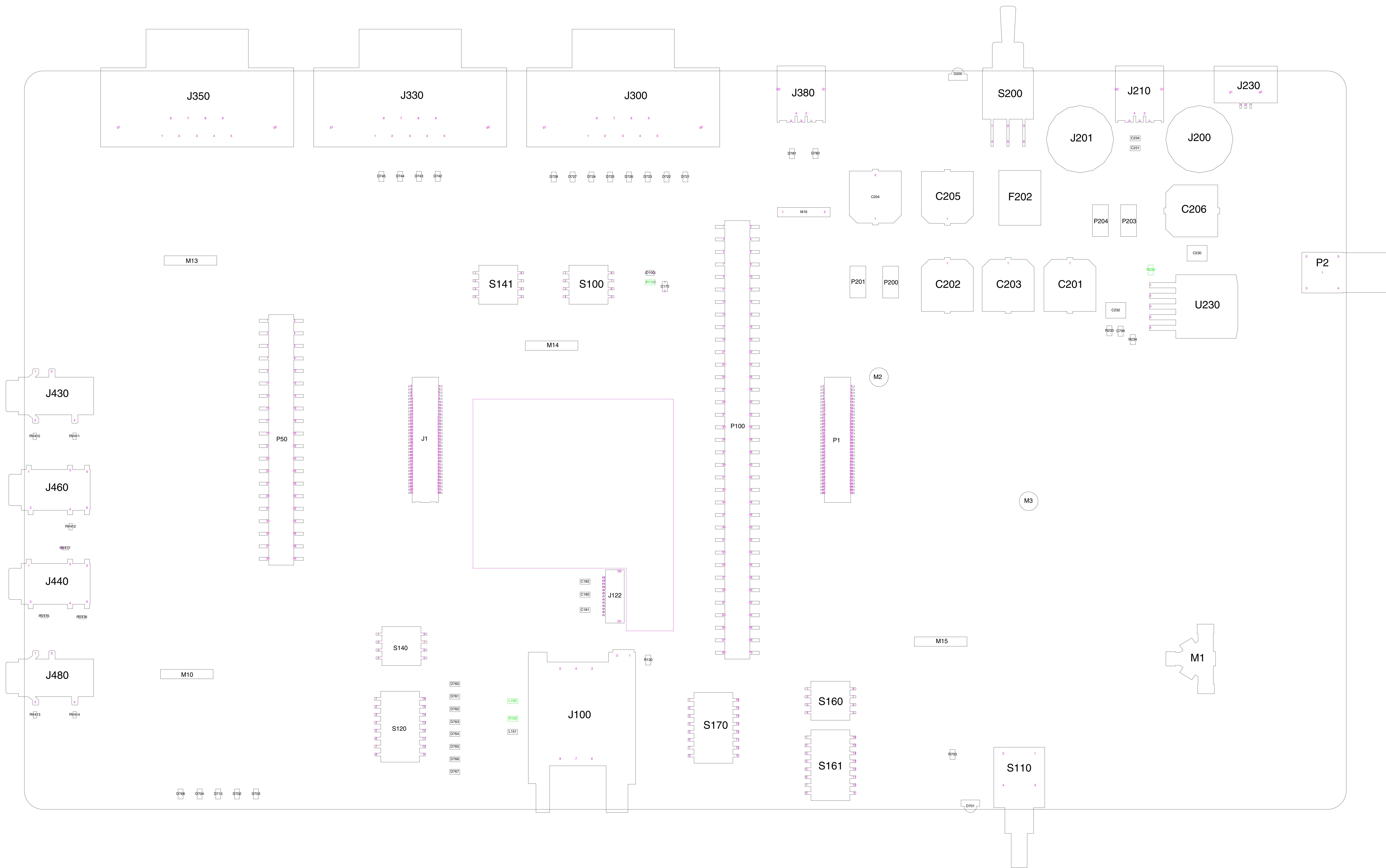

Bottom Side Components View

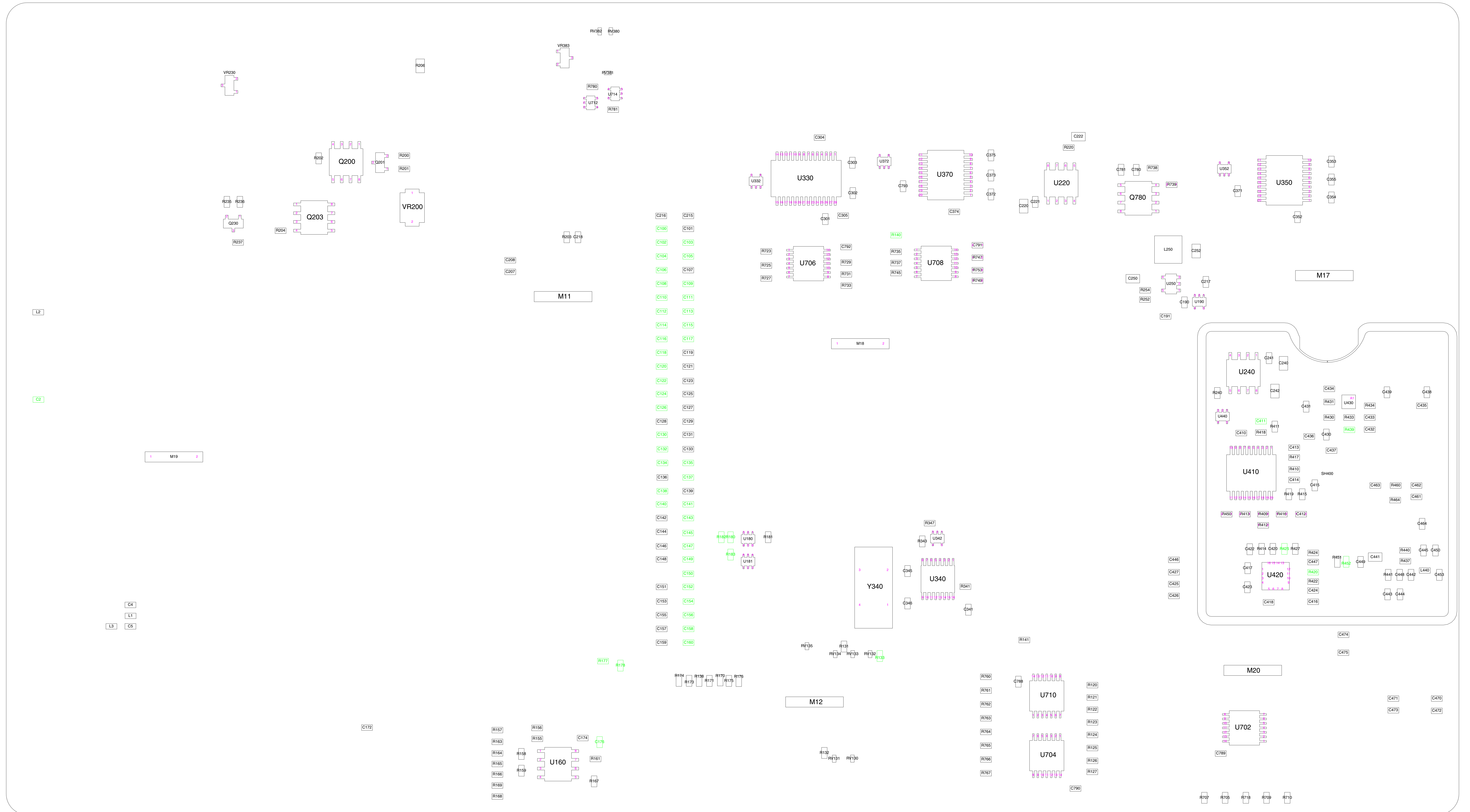

Acronyms and Abbreviations

Abbreviation	Full Name
A	
ADC	Analog to Digital Converter
C	
CMOS	Complementary Metal Oxide Semiconductor
CODEC	Coder-Decoder
D	
DIAG	Diagnostics
DTE	Data Terminal Equipment (such as terminals, PCs and so on)
E	
EGPRS	Enhanced General Packet Radio Service
EME	Electromagnetic Emission
ESD	Electro-Static Discharge
EVB	Evaluation Board
G	
GPRS	General Packet Radio Service
GSM	Global System for Mobile Communications
I	
IRQ	Interrupt Request
L	
LED	Light Emitting Diode
M	
MIDI	Musical Instrument Digital Interface
MMCX	Mini Micro Coax
MMI	Man-Machine Interface
O	
OEM	Original Equipment Manufacturer

Abbreviation	Full Name
P	
PCM	Pulse Code Modulation
R	
RF	Radio Frequency
S	
SIM	Subscriber Identity Module
SPI	Serial Peripheral Interface
U	
UART	Universal Asynchronous Receiver Transmitter
USB	Universal Serial Bus
UUT	Unit Under Test

Index

Numerics

70-pin Connectors, 7

A

AC Adapter
 Connector Pins, 13
Accessories, 3
Alert Transducer, 5
Antenna, viii, 7, 10–11
 External, 18
 Internal, 20
Audio, 5

C

Communications, 10, 16

D

Debugging, 5
Developer Board
 Board Number, 3
 ESD, viii
Diagnostics, 16
 Connector, 25

E

External DC Power, 10, 12, 14
External Power Source
 Jumpers, 14

G

G24
 Connecting to Antenna, 7
 Header Connection, 25
GND, 14
GSM
 Reception, 18

H

Header Connection, 5
Header Connector, 27–28
Host Connector, 25
 Flex Cable, 25

J

Jumpers, 5, 29

Power Source, 12, 26

L

LEDs, 5, 11, 31

M

MMCX Connector, 7

O

OEM, vii

P

Parts List, 3
Power Jumpers, 12
Power Supply, 5
 AC Adapter, 9, 12
 Battery, 10
 Developer Board Power Jumper, 15
 External DC Power, 10, 14
 Jumpers, 12, 15, 26
 Power Jumper, 15
 VCC, 14
 Voltage, 14
Power Switch, 9

R

RF Cable, 7, 11, 20
RS232, 10, 16
 Connector Pins, 16

S

SIM Card, 5
Spacers, 7
Support Center, 33
Switches, 5, 29

U

USB, 10, 16–17
 Connector Pins, 17
UUT, 25

V

Voltage
 AC Adapter, 13





MOTOROLA and the Stylized M Logo are registered in the US Patent & Trademark Office.

All other product or service names are the property of their respective owners.

©Copyright 2005 Motorola, Inc.

Java™ Technology and/or J2ME™ : Java and all other Java-based marks are trademarks or registered trademarks of Sun Microsystems, Inc. in the U.S. and other countries.

UNIX® : UNIX is a registered trademark of The Open Group in the United States and other countries.



6802985C05-A