



MOTOROLA

Material or Methods Specification

NO. **51R70200D09**

TITLE: **Module, GPS receiver with TCXO, 8.6x8.6x1.55mm, 32 I/O LGA, SMD, W18 Compliant**

REVISION DATE: **3 Dec 07**

ISSUE: **0**



G24 Module + GPS



TABLE OF CONTENTS

1	SCOPE	3
2	APPLICABLE DOCUMENTS	3
3	DESCRIPTION.....	3
4	COMPONENT REQUIREMENTS.....	4
4.1	General Requirements.....	4
4.2	Electrical Requirements.....	6
4.3	Mechanical Requirements.....	12
4.4	Factory Automation and Identification.....	16
4.5	Manufacturing Environments	17
4.6	Commands settings for Autonomous OneTrack Always	18



1 SCOPE

This document contains general Motorola electrical and mechanical definitions for the GPS receiver module.

2 APPLICABLE DOCUMENTS

SiRF Family of GPS Receivers - Instant GPS IC Interface Control drawing document

Note:

More information on Motorola GPS Module, Reference Design and SiRF is available on MOTODEV.com

3 DESCRIPTION

The GPS module makes use of a GSCi5001 IC, two saw filters, one LNA IC and other supporting components to receive and decode GPS signals using passive or active antenna structure. It contains all the functional blocks to perform Autonomous, MS-Based or MS-Assisted A-GPS. For automatic handling, these parts are delivered on tape and reel as specified in Section 4.4. Also, this package and terminations are designed for exposure to lead-free reflow soldering systems in accordance to Section 4.5.



4 COMPONENT REQUIREMENTS

4.1 General Requirements

4.1.1 Operating Temperature Range: -20°C to +85°C without loss of function.

4.1.2 Storage Temperature Range:

Components only: -40°C to +85°C after soldered onto PC Board.

In Tape / Reel's*: -10°C to +50°C with 70% RH maximum.

***Note:** Return to ambient room temperature before using.

4.1.3 **ESD Rating:** Minimum ESD rating for this device is ± 2000 V Human Body Model (HBM), with the exception of Pin 3, 7 and 31.

Pin	ESD Rating(Volts)	Pin	ESD Rating(Volts)
1	2000	17	2000
2	2000	18	2000
3	180	19	2000
4	2000	20	2000
5	2000	21	2000
6	2000	22	2000
7	1000	23	2000
8	2000	24	2000
9	2000	25	2000
10	2000	26	2000
11	2000	27	2000
12	2000	28	2000
13	2000	29	2000
14	2000	30	2000
15	2000	31	1000
16	2000	32	2000



4.1.4 Moisture Sensitivity: Required moisture sensitivity level **MSL = 3**.

LEVEL	DURATION OUT OF DRY PACK
MSL 1	No dry pack required
MSL 2	One year
MSL 2a	4 weeks
MSL 3	168 hours
MSL 4	72 hours
MSL 5	48 hours
MSL 5a	24 hours

Note: MSL one through three are acceptable for production.

All moisture sensitive devices shall be packed in protective bags per the following information:

Duration out of dry pack refers to the maximum component exposure time at 10 to 30°C while not exceeding 60% relative humidity. Opened containers that will not be used before the time stated in the above table (ref J-STD-020 section 7 table 2) should either be stored in a dry box or re-sealed in a moisture-proof bag with desiccant and stored in conditions of 10 to 30°C. The exposure time out of the original bag, a dry box or re-sealed bag is additive.

4.2 Electrical Requirements

4.2.1

All specifications must be met under an RF port mismatch of up to -10 dB return loss, over temperature extremes $-20^{\circ}\text{C} < T < +85^{\circ}\text{C}$ unless otherwise stated, and over operational voltage extremes.

Spec. Item	Parameter	Condition	Min	Typ	Max	Unit
4.2.1.1	<u>Voltage Supplies</u>					
4.2.1.1.1	VCC_1.8V, VDD_1.8V		1.71	1.8	1.98	V
4.2.1.1.2	VDD_1.2V		1.15	1.2	1.32	V
5.2.1.1.3	BPLUS		3.05	3.7	5	V
4.2.1.2	<u>Current Drain</u>					
4.2.1.2.1	Total Supply Current		10.7	18	27	mA
	VCC_1.8V + VDD_1.8V (LI only initial search)					
4.2.1.2.2	Total Supply Current		10.7	18	27	mA
	VCC_1.8V + VDD_1.8V (LI only Tracking)					
4.2.1.2.3	Total Supply Current		-	2.5	10	uA
	VCC_1.8V + VDD_1.8V (Quiescent, at +25°C)					
4.2.1.2.4	VDD_1.2V Supply Current		-	80	98	mA
	(Initial search)					
4.2.1.2.5	VDD_1.2V Supply Current		-	13	38	mA
	(Tracking, Trickle Power Mode)					
4.2.1.2.6	VDD_1.2V Supply Current		-	24	38	mA
	(Tracking, Non-Trickle Power Mode)					
4.2.1.2.7	VDD_1.2V Reset Current		-	4	25	uA
	(Quiescent, at +25°C)					
4.2.1.2.8	BPLUS Current		-	6.8	7.5	mA

Spec. Item	Parameter	Condition		Min	Typ	Max	Unit
4.2.1.3	<u>RF tests</u>						
		F1	F2				
4.2.1.3.1	P2dB out-of-band jamming for a 2dB C/No drop	1575.42	845	24	26	-	dBm
4.2.1.3.2	(CW signal used)	1575.42	915	24	26	-	dBm
4.2.1.3.3		1575.42	1710	16	20	-	dBm
4.2.1.3.4		1575.42	1850	16	20	-	dBm
4.2.1.3.5		1575.42	1920	16	20	-	dBm
4.2.1.3.6		1575.42	2400	20	22	-	dBm
4.2.1.3.7	IIP3 for a 2dB C/No drop	1573.42	1574.42	-106	-102	-	dBm
4.2.1.3.8	(CW signal used)	1576.42	1577.42	-102	-98	-	dBm
4.2.1.3.9		1712.71	1850	-4	-1	-	dBm
4.2.1.3.10		1742.71	1910	-3	0	-	dBm
4.2.1.3.11		1747.71	1920	-2	0	-	dBm
4.2.1.3.12		1762.71	1950	-2	0	-	dBm
4.2.1.3.13		1777.71	1980	-3	0	-	dBm
4.2.1.3.14	Dynamic Range	Please see table 1					
4.2.1.3.15	C/No (ORA mode)	Tracking channels with channel status >=5 & frequency lock = 10		43	47	51	dBHz
	(Based on -120dBm conducted power, no patch firmware is loaded)						

4.2.2

All specifications must be met under an RF port mismatch of up to 11 dB return loss, at +25C unless otherwise stated.

Spec. Item	Parameter	Condition	Typ	Max	Unit	
4.2.2.1	<u>One Range Always (ORA) Performance</u>					
4.2.2.1.1	C/No (Based on -120dBm conducted power, no patch firmware is loaded)	Tracking channels with channel status >=5 & frequency lock = 10	44	47	50	dBHz
4.2.2.1.2	Total Supply Current VCC_1.8V + VDD_1.8V (L1 only Tracking)		12	16	22	mA
4.2.2.1.2	VDD_1.2V Supply Current (L1 only Tracking)		-	14	30	mA
4.2.2.2	<u>One Track Always (OTA or Autonomous) Performance</u>	See note 3.				
4.2.2.2.1	Cold Start TTFF	95% @ -136dBm		<60	s	
4.2.2.2.2	Warm Start TTFF	95% @ -136dBm		<45	s	
4.2.2.2.3	Hot start TTFF	95% @ -136dBm		<10	s	
4.2.2.2.4	Hot start TTFF	50% @ -145dBm		<10	s	
4.2.2.2.5	Hot start TTFF	50% @ -147dBm		<10	s	
4.2.2.2.6	Cold start first 3D (Horizontal Accuracy only)	95% @ -136dBm		<20	m	
4.2.2.2.7	Continuous navigation (Horizontal Accuracy)	95% @ -136dBm		<10	m	
4.2.2.2.8	Velocity (tracking) (Deviation from true velocity)	@ -136dBm		<1	m/s	
4.2.2.2.9	Re-acquisition time (see note 1 below)	After 30s outage, 95%		<3	s	
4.2.2.2.10	Data Decode sensitivity (Acquisition sensitivity)			-142	dBm	
4.2.2.2.11	Tracking sensitivity			-154	dBm	

Spec. Item	Parameter	Condition		Typ	Max	Unit
4.2.2.3	<u>Assisted mode performance</u>	See note 3.				
4.2.2.3.1	3GPP RAN 4	Pass all tests – MS-B and MS-A	N.A.		N.A.	
4.2.2.3.2	MS-Based TTF					
	(see note 2 on -139dBm TTF and accuracy)	50% @ -139dBm			<8	s
		67% @ -139dBm			<10	s
		95% @ -139dBm			<10	s
		50% @ -145dBm			<7	s
		67% @ -145dBm			<8	s
		95% @ 145dBm			<8	s
		50% @ -150dBm			<20	s
		67% @ -150dBm			<30	s
		50% @ -152dBm			<30	s
		67% @ -152dBm			<45	s
4.2.2.3.3	MS-Based Accuracy					
	(Horizontal Accuracy)					
		50% @ -139dBm			<10	m
		67% @ -139dBm			<15	m
		95% @ -139dBm			<25	m
		50% @ -145dBm			<50	m
		67% @ -145dBm			<60	m
		95% @ 145dBm			<70	m
		50% @ -150dBm			<50	m
		67% @ -150dBm			<80	m
		50% @ -152dBm			<70	m
		67% @ -152dBm			<120	m

Note 1:

Re-acquisition tests are measured based on a simulated signal but correlated with the DUT measured from a live satellite signal.

Note 2:

These TTF parameters @ -139dBm were degraded as a trade-off made to meet E911 accuracy requirement.

Note 3:

All tests were run with patch 3 build 0x4f.

Dynamic Range			
Input Power (dBm)	C/No		
	Minimum	Typical	Maximum
-120	47.30	48.30	49.30
-121	46.80	47.60	48.10
-122	45.90	47.00	47.80
-123	44.80	46.50	47.10
-124	43.70	45.70	46.60
-125	43.00	44.90	45.60
-126	42.00	43.90	44.80
-127	41.20	42.90	43.40
-128	40.30	41.90	42.60
-129	39.30	41.00	41.80
-130	38.30	40.10	41.20
-131	37.50	38.90	39.70
-132	36.00	37.80	38.80
-133	35.10	36.80	37.90
-134	34.10	35.80	36.90
-135	33.40	34.80	35.80
-136	32.20	33.90	34.80
-137	31.20	32.80	33.60
-138	30.10	31.70	32.70
-139	28.80	30.77	31.70
-140	27.80	29.60	30.80
-141	26.60	28.60	29.90
-142	25.30	27.56	28.80
-143	24.30	26.50	27.90
-144	22.70	25.40	27.10
-145	21.30	24.30	26.10
-146	21.20	23.20	25.20
-147	19.90	22.50	24.50
-148	19.20	21.50	23.70
-149	18.50	20.60	22.30
-150	17.90	19.80	21.70
-151	16.20	18.70	20.60
-152	15.10	17.80	19.60
-153	13.90	16.70	18.40

4.2.3 Application circuit:

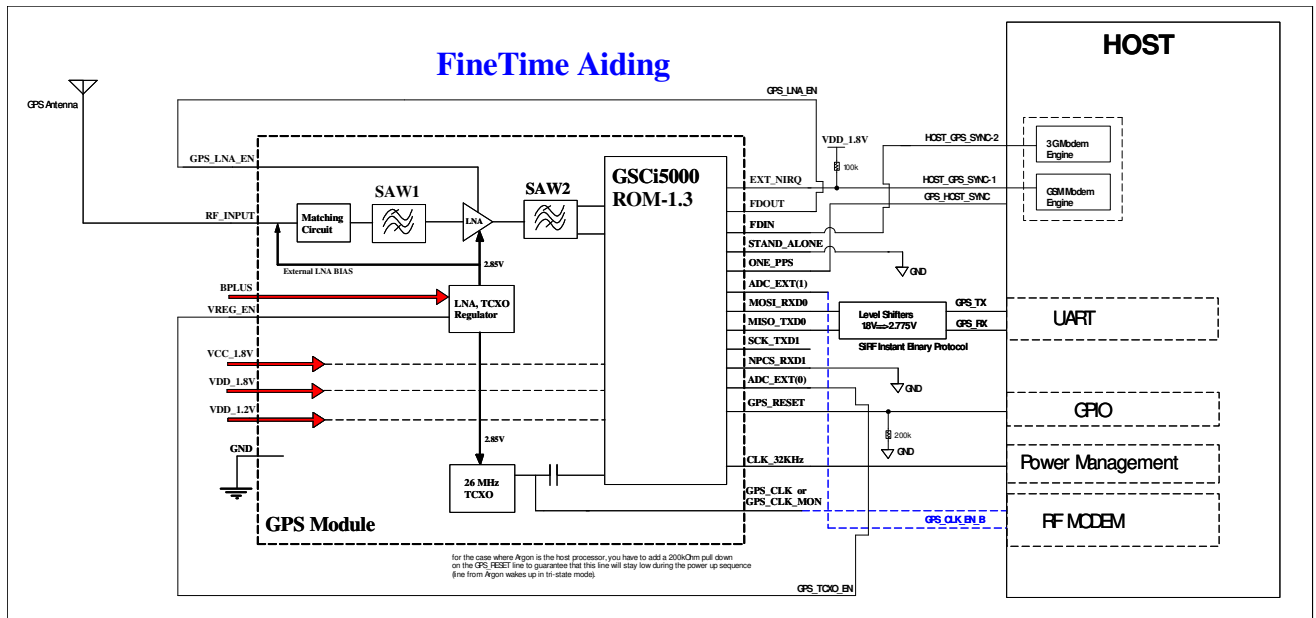
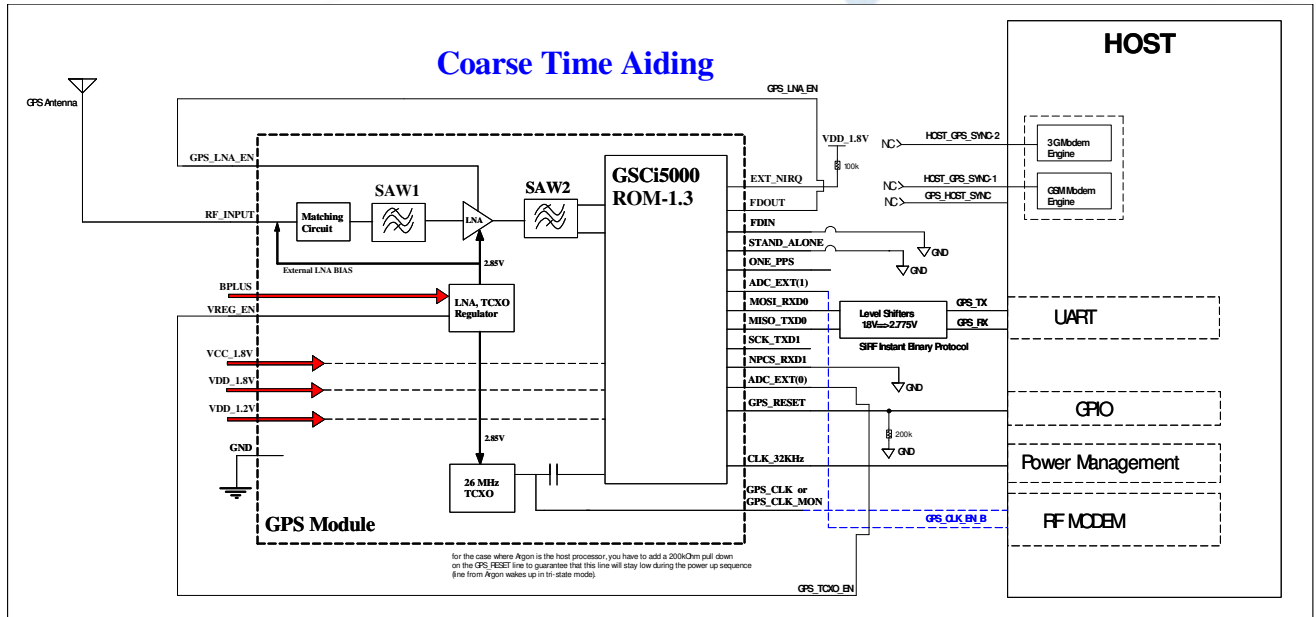



4.3 Mechanical Requirements

- 4.3.1 Construction: 32 pin LGA package with center ground pad.
- 4.3.2 Immersion Gold Plating: Gold plating shall be 0.05 micron to 0.25 micron over 2.5 microns to 6.5 microns low stress nickel. A maximum phosphorous content of 10% by weight should be maintained. Unless otherwise indicated on the fabrication drawing, boards shall meet solderability requirements as specified in **J-STD-003** for a period of 180 days from the date of receipt of Motorola. To aid vision recognition equipments the Ni/Au plating on the module pads must be matte finish.
- 4.3.3 Termination/Component Flatness:
Co-planarity (from seating plane): 0.1 mm (0.004 inches) maximum
Component Flatness: Over the longest diagonal dimension, the bottom of the package shall not deviate from an ideal flat surface by more than 0.05 mm (0.002 inches)
- 4.3.4 Modular Component Solder: For soldering the components onto the PCB, the supplier should use 95.5% Tin (Sn), 3.8% Silver (Ag) and 0.7% Copper (Cu) alloy. A high temperature solder is required to ensure that when the module is reflowed onto the PC Board, the components on the module itself does not reflow.

4.3.5

IC Package Configuration: (Top View of Bottom I/O – view through top of package)

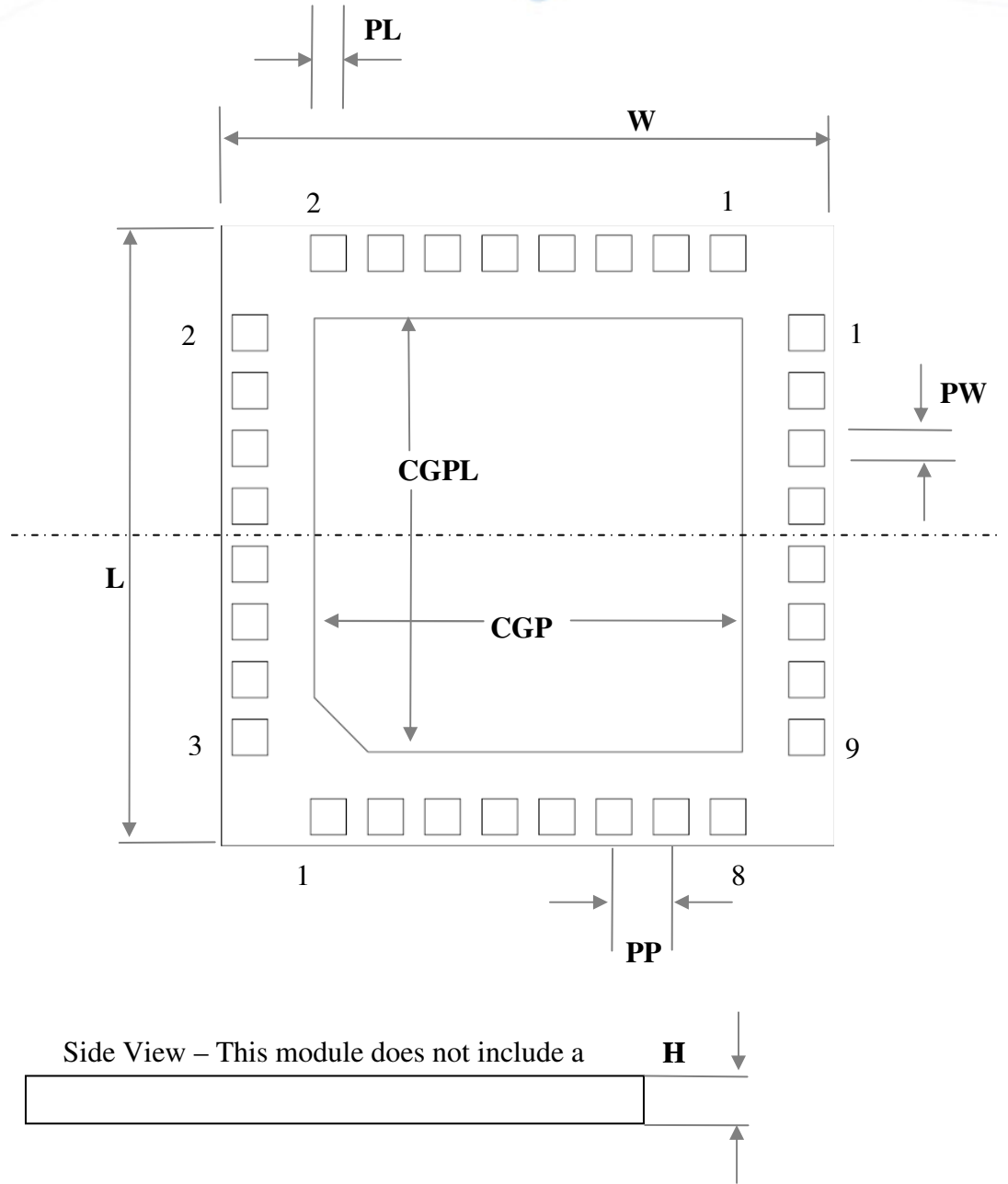

	Symbol	Nominal units:	Max millimeters	Min
Overall Body Height:	H		1.55	-
Package Body Length:	L	8.60	8.70	8.50
Package Body Width:	W	8.60	8.70	8.50
I/O Pad Width:	PW	0.50	0.55	0.45
I/O Pad Pitch:	PP	0.80	0.85	0.75
I/O Pad Length	PL	0.50	0.55	0.45
Center Gnd Pad Width	CGPW	6.00	6.10	5.90
Center Gnd Pad Length	CGPL	6.00	6.10	5.90

FIGURE 1 Module Package Dimensions

4.3.6 Pin-out Identification:

Name	No.	I/O	Description
VREG_EN	1	I	Module TCXO and external LNA voltage regulator enable logic pin (will be connected external to module to ADC_EXT(0))
GND	2	I	Ground
RF Input	3	I	connected to GPS antenna output pin
GND	4	I	Ground
BPLUS	5		Battery B+ dc power supply from phone to power the TCXO regulator (+2.9 to +4.3V)
GND	6	I	Ground
GPS_CLK_MON	7	O	TCXO clock output monitor pin, to be used as an alternative clock in the phone
EXT_NIRQ	8	I	External interrupt input blanking signal from LTE based phone, connected to EXC_EN or some receive signal
GND	9	I	Ground
FDOUT	10	I/O	Logic control signal used to enable/disable the GPS LNA inside the module for trickle power mode for ROM1.3
FDIN	11	I/O	not used, it can be connected to the data output of a serial flash memory or can be a general purpose input
STAND_ALONE	12	I	this signal is a read only input which tells the processor the type of the startup mode of MGX1 (Discovery Mode, Flash Download Mode, ROM Execution Mode)
GND	13	I	Ground
ONE_PPS	14	O	one pulse per second accurate output signal, used only when performing accurate time transfer from external circuit
ADC_EXT(1)	15	I/O	Logic control signal "GPS_CLK_EN_B" to enable the external GPS clock buffer outside the module

Name	No.	I/O	Description
MOSI_RXD0	16	I	Serial interface bus receiver digital input
GND	17	I	Ground
VDD_1.8V	18	I	Digital and interface dc power supply voltage
MISO_TXD0	19	O	Serial interface transmitter digital output
GND	20	I	Ground
SCK_TXD1	21	I/O	Serial interface bus receiver digital input
GND	22	I	Ground
VDD_1.2V	23	I	Digital core internal dc power supply voltage.
NPCS_RXD1	24	I/O	Serial interface transmitter digital output
VCC_1.8V	25	I	Analog dc power supply voltage
GND	26	I	Ground
GND	27	I	Ground
CLK_32KHz	28	I	32.768kHz Real time clock (from PCAP2 Power Audio IC)
GND	29	I	Ground
ADC_EXT(0)	30	I/O	Logic control signal "GPS_TCXO_EN" to enable the internal TCXO regulator inside the module and to enable the external LNA regulator with the case of active antenna design.
GPS_LNA_EN	31	I	GPS module external LNA enable logic pin (will be connected to ADC_EXT(0) external to module)
GPS_RESET	32	I	GPS Reset Input from MCU

4.4 Factory Automation and Identification

4.4.1 Tape Width: 24 mm

4.4.2 Tape Pitch (part to part): 12 mm

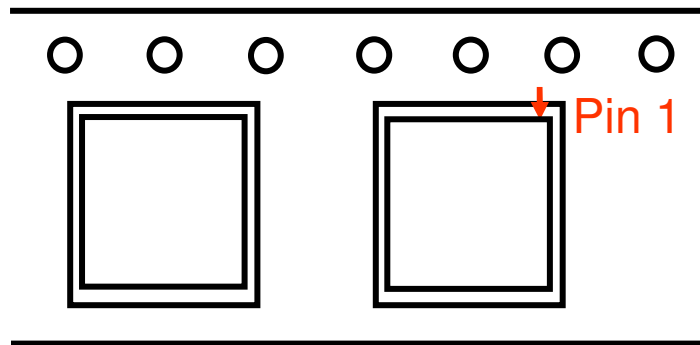

4.4.3 Component Orientation: Parts are to be oriented with the pad one side closest to the tape's round sprocket holes on the tape's trailing edge.

4.4.4 Reel Diameter: 330 mm (13 inch)



4.5 Manufacturing Environments

NOTE: All components must fully conform to electrical and mechanical specifications in sections Electrical Requirements and Mechanical Requirements of this document, after exposure to the manufacturing environments listed below.

- 4.5.1 Component Handling: All necessary special handling techniques shall be adopted in order to avoid contamination of metallization / terminations. Examples include use of finger cots, plastic tweezers, etc.
- 4.5.2 Lead Free Processing: Reference Reflow Temperature Regime for other products requiring higher processing temperature in Document 12G13933A12, "Component Temperature Requirements to Support Pb-FREE Solder Assembly," paragraph 2.4.2.

<u>Condition</u>	<u>Exposure</u>
Average ramp-up rate (30°C to 217°C)	Less than 3°C/second
>100°C seconds	Between 360-600
> 150°C	at least 240 seconds
> 217°C	at least 90 seconds
Peak Temperature	260°C -5/+0°C
Cool-down rate (Peak to 50°C)	Less than 6°C/second
Time from 30°C to 255°C seconds	No greater than 360

4.5.3 Processing Conditions:

- 4.5.3.1 Solder-ability: Terminations of part exposed to molten solder at 217°C for 90 seconds or with the minimum reflow conditions. The customer shall comply with the warranty as specified on the Motorola Purchase Order.
- 4.5.3.2 Solder Alloy: Motorola accepted lead-free solder alloy is 95.5/3.8/0.7 tin/silver/copper or its equivalent.



4.6 Commands settings for Autonomous OneTrack Always

This set of commands will please GPS module on Autonomous OneTrack Always settings

```
// Wake up Command
@@Oi
pause 1
```

```
// Set to default
@@Oo
pause 1
```

```
// Use this OF message for the latest ROM1.2 parts.
@@OFBB00000100000100FFFFFFFFFFFFFFFFFFFFFFFFFFFFFFFF
pause 1
```

```
// Use the following Oj message if the reference is 26.0000MHz
// 26.0000 MHz Ref // 147.423 MHz // 18.428 MHz MCLK // 19.196 Kb - full power
mode
// 26.0000 MHz Ref // 88.474 MHz // 11.0592 MHz MCLK // 19.200 Kb - CPU power
mode
@@@OjBB000A0370073CFF1192070A8B0700001E001E00120012
pause 1
```

```
// settings (Ana Fra-N, Ref_div=1, DCO locked to 32KHz, MCLK = Ref_div, LNA on,
TCXO-type reference)
@@@OFBB00020000010100FFFFFFFFFFFFFFFFFFFFFFFFFFFFFFFF
//pause 1
```

```
// 26.0000 MHz Ref // 147.423 MHz DCO // 26.0000 MHz MCLK // 19.345 Kb - full
power mode
// 26.0000 MHz Ref // 88.474 MHz DCO // 26.0000 MHz MCLK // 19.345 Kb - cpu
power mode
@@@OjBB000A0370073CFF1192070A8B0700002A002A002A002A
//pause 1
```

```
// Request @@Ou data (Satellite Data)
@@@OtA50000010001
```

```
// Request position fixes (@@Pb) in OneTrack Always Mode
@@@Oa04003C001D0F7F00020101
```



// Use this command in order to reduce traffic between GPS module and host.
// This command turns off pb data, only NMEA data will be transfer.

```
$PMOTG,GGA,1*31  
$PMOTG,GSA,1*25  
$PMOTG,GSV,1*36  
$PMOTG,RMC,1*2C
```

Note:

More information is available on MOTODEV.com