

*MOTOROLA G24 DEVELOPER'S GUIDE*

*MODULE HARDWARE DESCRIPTION*



## *SPECIFICATIONS SUBJECT TO CHANGE WITHOUT NOTICE*

### **Notice**

While reasonable efforts have been made to assure the accuracy of this document, Motorola, Inc. assumes no liability resulting from any inaccuracies or omissions in this document, or from use of the information obtained herein. The information in this document has been carefully checked and is believed to be entirely reliable. However, no responsibility is assumed for inaccuracies or omissions. Motorola, Inc. reserves the right to make changes to any products described herein and reserves the right to revise this document and to make changes from time to time in content hereof with no obligation to notify any person of revisions or changes. Motorola, Inc. does not assume any liability arising out of the application or use of any product, software, or circuit described herein; neither does it convey license under its patent rights or the rights of others.

It is possible that this publication may contain references to, or information about Motorola products (machines and programs), programming, or services that are not announced in your country. Such references or information must not be construed to mean that Motorola intends to announce such Motorola products, programming, or services in your country.

### **Copyrights**

This instruction manual, and the Motorola products described in this instruction manual may be, include or describe copyrighted Motorola material, such as computer programs stored in semiconductor memories or other media. Laws in the United States and other countries preserve for Motorola and its licensors certain exclusive rights for copyrighted material, including the exclusive right to copy, reproduce in any form, distribute and make derivative works of the copyrighted material. Accordingly, any copyrighted material of Motorola and its licensors contained herein or in the Motorola products described in this instruction manual may not be copied, reproduced, distributed, merged or modified in any manner without the express written permission of Motorola. Furthermore, the purchase of Motorola products shall not be deemed to grant either directly or by implication, estoppel, or otherwise, any license under the copyrights, patents or patent applications of Motorola, as arises by operation of law in the sale of a product.

### **Computer Software Copyrights**

The Motorola and 3rd Party supplied Software (SW) products described in this instruction manual may include copyrighted Motorola and other 3rd Party supplied computer programs stored in semiconductor memories or other media. Laws in the United States and other countries preserve for Motorola and other 3rd Party supplied SW certain exclusive rights for copyrighted computer programs, including the exclusive right to copy or reproduce in any form the copyrighted computer program. Accordingly, any copyrighted Motorola or other 3rd Party supplied SW computer programs contained in the Motorola products described in this instruction manual may not be copied (reverse engineered) or reproduced in any manner without the express written permission of Motorola or the 3rd Party SW supplier. Furthermore, the purchase of Motorola products shall not be deemed to grant either directly or by implication, estoppel, or otherwise, any license under the copyrights, patents or patent applications of Motorola or other 3rd Party supplied SW, except for the normal non-exclusive, royalty free license to use that arises by operation of law in the sale of a product.

### **VENDOR COPYRIGHT**

Apache Software Foundation Copyright 2004-2005 All Rights Reserved

## Usage and Disclosure Restrictions

### License Agreements

The software described in this document is the property of Motorola, Inc. and its licensors. It is furnished by express license agreement only and may be used only in accordance with the terms of such an agreement.

### Copyrighted Materials

Software and documentation are copyrighted materials. Making unauthorized copies is prohibited by law. No part of the software or documentation may be reproduced, transmitted, transcribed, stored in a retrieval system, or translated into any language or computer language, in any form or by any means, without prior written permission of Motorola, Inc.

### High Risk Materials

Components, units, or third-party products used in the product described herein are NOT fault-tolerant and are NOT designed, manufactured, or intended for use as on-line control equipment in the following hazardous environments requiring fail-safe controls: the operation of Nuclear Facilities, Aircraft Navigation or Aircraft Communication Systems, Air Traffic Control, Life Support, or Weapons Systems (High Risk Activities"). Motorola and its supplier(s) specifically disclaim any expressed or implied warranty of fitness for such High Risk Activities.

## Trademarks



MOTOROLA and the Stylized M Logo are registered in the US Patent & Trademark Office. All other product or service names are the property of their respective owners.

©Copyright 2006 Motorola, Inc.

REV052604





## Table of Contents

---

Manual Scope	.ix
Target Audience	.ix
Manual Organization	.ix
Applicable Documents	.ix
Regulatory Requirements	.x
Regulatory Statement (Safety)	.x
Antenna and Transmission Safety Precautions	.x
Standards	.xi
Contact Us	.xii
Text Conventions	.xii
Field Service	.xiii
General Safety	.xiii
Caring for the Environment	.xiv
Limitation of Liability	.xv
Warranty Notification	.xv
How to Get Warranty Service?	.xvi
Claiming	.xvi
Conditions	.xvii
What is Not Covered by the Warranty	.xvii
Installed Data	.xviii
Out of Warranty Repairs	.xviii
Revision History	.xix
<b>Chapter 1: Introduction</b>	<b>1</b>
Product Specifications	2
Regulatory Approvals	5
CFR 47 Part 15.19 specifies label requirements	5
CFR 47 Part 15.21 Information to user	5
CFR 47 Part 15.105 Information to the user	5
<b>Chapter 2: Hardware Interface Description</b>	<b>7</b>
Architecture Overview	7
Digital Block	8
Analog Block	8
GSM Transceiver Block	8
Operating Modes	9
Power Supply	10
Power Supply Design	10
Power Consumption	11
Power On/Off Operation	14
Turning the G24 On	14
Power Supply Turn-on	14
Turning the G24 On Using ON_N	15
Turning the G24 On Using IGN	16

Turning the G24 Off . . . . .	16
Turning the G24 Off Using ON_N . . . . .	16
Turning the G24 Off Using IGN . . . . .	17
Power Loss shut down . . . . .	18
Turning the G24 Off Using AT+MRST . . . . .	18
Low Power Mode . . . . .	19
Activating Low Power Mode . . . . .	19
Serial Interface During Low Power Mode . . . . .	20
Terminating Low Power Mode . . . . .	20
Temporary Termination of Low Power Mode . . . . .	21
Permanent termination of Low Power Mode . . . . .	22
Real Time Clock . . . . .	23
Serial Interfaces . . . . .	24
Primary UART (UART1) . . . . .	24
Secondary UART (UART2) . . . . .	25
USB Interface . . . . .	25
SIM Interface . . . . .	26
SIM Connection . . . . .	26
SIM Design Guidelines . . . . .	27
Audio Interface . . . . .	28
Handset Microphone Port . . . . .	28
Headset Microphone Port . . . . .	29
Speaker Port . . . . .	30
Headset Detection . . . . .	32
Alert Loudspeaker Port . . . . .	33
Digital Audio Interface . . . . .	34
Voiceband Audio . . . . .	35
Stereo Audio . . . . .	36
Operating Modes . . . . .	36
Basic Mode . . . . .	36
Advanced Mode . . . . .	37
Audio Programming Interface . . . . .	38
Audio Algorithms . . . . .	38
Gain Control . . . . .	39
Audio Design . . . . .	40
Analog Ground . . . . .	41
A/D Interface . . . . .	42
Power Supply A/D . . . . .	42
Temperature A/D . . . . .	43
General Purpose A/D . . . . .	45
Controls and Indicators Interface . . . . .	46
Reset . . . . .	46
VREF Reference Regulator . . . . .	46
OFF Mode . . . . .	47
Standby Mode . . . . .	47
Active Mode . . . . .	47
Wakeup Out . . . . .	48
Antenna Detection . . . . .	49
GPRS/EGPRS Detection . . . . .	49
Transmission Indicator . . . . .	50
General Purpose I/O . . . . .	50
Antenna Interface . . . . .	51

---

<b>Chapter 3: Electrical and Environmental Specifications</b> .....	<b>53</b>
Absolute Maximum Ratings .....	53
Environmental Specifications .....	54
Application Interface Specifications .....	54
<b>Chapter 4: Mechanical Specifications</b> .....	<b>61</b>
Board Dimensions .....	61
Interface Connector Specifications .....	62
Mating Connectors .....	63
RF Connector Specifications .....	64
Mating Connector .....	64
G24 Mounting .....	66
<b>Chapter 5: Service and Testing</b> .....	<b>67</b>
Service .....	67
Who to Contact? .....	67
Required Query Information .....	67
Motorola Workflow .....	68
Service Centers .....	69
Testing a Standalone Unit .....	70
Test Setup .....	70
Test Procedure .....	72
<b>Acronyms and Abbreviations</b>	
<b>Index</b>	





## List of Figures

---

Figure No.	Figure Title	Page No.
2-1	G24 Block Diagram . . . . .	7
2-2	Transmission Power Drops . . . . .	10
2-3	Power Supply Turn-on and Off . . . . .	15
2-4	ON_N Power On Timing . . . . .	15
2-5	IGN Power On Timing . . . . .	16
2-6	ON_N Power Off Timing . . . . .	17
2-7	IGN Power Off Timing . . . . .	17
2-8	ATS24 Operation . . . . .	19
2-9	CTS Signal During Sleep Mode . . . . .	20
2-10	WKUPI_N Signal Operation . . . . .	21
2-11	Serial Interface Data . . . . .	22
2-12	UART1 Interface Signals . . . . .	24
2-13	UART2 Interface Signals . . . . .	25
2-14	USB Interface Signals . . . . .	25
2-15	G24 SIM Interface . . . . .	26
2-16	Audio Interface Topology . . . . .	28
2-17	Handset Microphone Circuit . . . . .	29
2-18	Headset Microphone Circuit . . . . .	30
2-19	Differential Speaker Circuit . . . . .	31
2-20	Single-ended Speaker Circuit . . . . .	31
2-21	Differential Loudspeaker Circuit . . . . .	33
2-22	Single-ended Loudspeaker Circuit . . . . .	33
2-23	Voiceband Mode PCM Bus Coding Format . . . . .	36
2-24	Stereo Mode PCM Bus Coding Format . . . . .	36
2-25	Audio Programming Interface . . . . .	38
2-26	Temperature A/D Characteristics . . . . .	43
2-27	VREF Power-up Timing . . . . .	47
2-28	WKUPO_N Operation . . . . .	49
2-29	TXEN_N Operation . . . . .	50
4-1	G24 Mechanical Characteristics . . . . .	61
4-2	G24 Interface Connectors . . . . .	62
4-3	Mating Connectors Dimensions . . . . .	63
4-4	MMCX Connector Dimensions . . . . .	64
4-5	Optional MMCX Cable Assembly . . . . .	65
5-1	Test Setup . . . . .	71



---

<b>Table No.</b>	<b>Table Title</b>	<b>Page No.</b>
1-1	Product Specifications . . . . .	2
2-1	G24 Operating Modes . . . . .	9
2-2	Power Supply Signals . . . . .	10
2-3	Recommended Power Supply Filtering . . . . .	11
2-4	G24 Current Ratings . . . . .	11
2-5	SIM Interface Signals . . . . .	26
2-6	Handset Microphone Port Specifications . . . . .	29
2-7	Headset Microphone Port Specifications . . . . .	30
2-8	Speaker Port Specifications . . . . .	32
2-9	Alert Port Specifications . . . . .	34
2-10	Digital Audio modes . . . . .	35
2-11	Basic Mode Audio Paths . . . . .	37
2-12	Advanced Mode Commands . . . . .	37
2-13	Speech Processing Features . . . . .	39
2-14	Gain Control Features . . . . .	39
2-15	Speaker Port Gains for Speech . . . . .	39
2-16	Microphone and Headset Microphone Port Gains . . . . .	40
2-17	A/D Signals . . . . .	42
2-18	Supply A/D Specifications . . . . .	43
2-19	Temperature Conversion Values . . . . .	44
2-20	Temperature A/D Specifications . . . . .	45
2-21	GPAD Specifications . . . . .	45
2-22	Controls and Indicators . . . . .	46
2-23	VREF Specifications . . . . .	48
2-24	Antenna Interface Specifications . . . . .	51
3-1	Maximum Ratings . . . . .	53
3-2	Environmental Ratings . . . . .	54
3-3	Interface Specifications . . . . .	55
4-1	G24 interface connector options . . . . .	62
4-2	Interface Connector Specifications . . . . .	62
4-3	RF Connector Specifications . . . . .	64



## Preface

---

### Manual Scope

This manual provides the electrical, mechanical and environmental requirements for properly integrating the G24 module in a host application.

This manual gives a complete set of hardware features and functions that may be provided by G24. The availability of any feature or function, which is described in this manual, depends on the hardware revision and software version of a specific G24 model.

The parameters and values provided in this manual are defined under typical conditions. These values may vary when subject to different conditions, such as SW version, network status, application settings and environmental conditions.

### Target Audience

This manual is intended for all members of the integration team who are responsible for integrating the G24 module into the host OEM device, including representatives from hardware, software and RF engineering disciplines.

### Manual Organization

This manual contains the following chapters:

- **Chapter 1**—introduces the G24 unit and provides important safety instructions.
- **Chapter 2**—provides a detailed hardware description of the blocks and components comprising the G24.
- **Chapter 3**—describes the pin assignments for G24 connectors.
- **Chapter 4**—describes G24 mechanical specifications and requirements.
- **Chapter 5**—provides contact information for Motorola Service Support and Customer Assistance.

### Applicable Documents

- G24 Developer's Kit - 6889192V26
- G24 AT Commands - 6889192V28

## Regulatory Requirements

The Federal Communications Commission (FCC) requires application for certification of digital devices in accordance with CFR Title 47, Part 2 and Part 15. This includes Electromagnetic Energy Exposure (EME) testing. As the G24 modem is not a standalone transceiver but is an integrated module, the G24 cannot be tested by itself for EME certification. It is, however, the integrator's responsibility to have the completed device tested for EME certification.

## Regulatory Statement (Safety)

The following safety precautions must be observed during all phases of the operation, usage, service or repair of any cellular terminal or mobile incorporating the G24 module. Manufacturers of the cellular terminal are advised to convey the following safety information to users and operating personnel, and to incorporate these guidelines into all manuals supplied with the product. Failure to comply with these precautions violates safety standards of design, manufacture and intended use of the product. Motorola assumes no liability for customer failure to comply with these precautions.

- The G24 must be operated at the voltages described in the technical documentation
- The G24 must not be mechanically nor electrically changed. Use of connectors should follow the guidance of the technical documentation
- The G24 is designed to meet the EMC requirements of ETS 300342
- When integrating the G24 into a system, Motorola recommends testing the system to ETS300342-1
- The G24 meets the safety requirements of EN60950
- Systems using the G24 are subject to mandatory EMC testing under directive 89/336/EEC (see item 3 above). Other directives, such as the LVD directive 73/23/EE, may also apply to a system using the G24 module

## Antenna and Transmission Safety Precautions

### User Operation

Do not operate your unit when a person is within 8 inches (20 centimeters) of the antenna. A person or object within 8 inches (20 centimeters) of the antenna could impair call quality and may cause the phone to operate at a higher power level than necessary.

---

**Important:** The unit must be installed in a manner that provides a minimum separation distance of 20 cm or more between the antenna and persons and must not be co-located or operate in conjunction with any other antenna or transmitter to satisfy FCC RF exposure requirements for mobile transmitting devices.

---

---

**Important:** To comply with the FCC RF exposure limits and satisfy the categorical exclusion requirements for mobile transmitters, the requirements described in the following section, "[Antenna Installation](#)", must be met.

---

## Antenna Installation

- The antenna installation must provide a minimum separation distance of 20 cm from users and nearby persons and must not be co-located or operating in conjunction with any other antenna or transmitter.
- The combined cable loss and antenna gain must not exceed +7.5 dBi (850 band). The combined cable loss and antenna gain must not exceed +2.5 dBi and total system output must not exceed 2.0W EIRP in the PCS (1900) band in order to comply with the EIRP limit of 24.232 (b). OEM installers must be provided with antenna installation instruction and transmitter operating conditions for satisfying RF exposure compliance.

## Standards

*Electromagnetic Compatibility: Principles and Applications* by David A Weston, published by Marcel Dekker, Inc., 270 Madison Avenue, New York, NY 10016 USA.

*GSM 07.07 - prETS 300 916*, Digital cellular telecommunication system (Phase 2+); AT command set for GSM Mobile Equipment (ME), Version 5.2.0 or higher, Reference RE/SMG-040707QR1.

*GSM 07.05*, Digital cellular telecommunication system (Phase 2+); Use of Data Terminal Equipment - Data Circuit terminating; Equipment (DTE-DCE) interface for Short Message Service (SMS) and Cell Broadcast Service (CBS), Version 5.3.0, August, 1997, Reference TS/SMG-040705QR2.

*GSM 03.40*, Digital cellular telecommunication system (Phase 2+); Technical realization of the Short Message Service (SMS) Point-to-Point (PP), Version 5.3.0, July 1996, Reference TS/SMG-040340QR2.

*GSM 04.11* Digital cellular telecommunication system (Phase 2+); Point-to-Point (PP) Short Message Service (SMS) support on mobile radio interface, Version 5.1.0, March 1996, Reference TS/SMG-030411QR.

*GSM 03.38*, Digital cellular telecommunication system (Phase 2+); Alphabets and language-specific information, Version 5.3.0, July 1996, Reference TS/SMG-040338QR2.

*GSM 11.10-1*, Digital cellular telecommunication system (Phase 2); Mobile Station (MS) Conformance specification; Part 1: Conformance specification. Draft pr ETS 300 607-1, March 1998, Reference RE/SMG-071110PR6-1.

GSM Specifications are orderable from Global Engineering Documents, 15 Inverness Way East, Englewood, Colorado 80112-5704 USA 303-792-2181 800-624-3974.

ETSI Standard PCS - *11.10-1*.

*GSM 02.30* Supplementary services.

*GSM 03.90* USSD stage 2.

*GSM 11.14* SIM toolkit.

ITU-T *V.25ter*

GSM Data Adapter for Motorola Handsets, AT command reference, Rev 2, June 9 1997.

ETSI standard SMG31.

GSM 05.02.

ETSI 07.60.

ETSI 0.7.07 Ver. 7.5.0.

## Contact Us

We at Motorola want to make this guide as helpful as possible. Keep us informed of your comments and suggestions for improvements.

For general contact, technical support, report documentation errors and to order manuals, use this email address:

M2M.CustomerCare@motorola.com

Motorola appreciates feedback from the users of our information.

## Text Conventions

The following special paragraphs are used in this guide to point out information that must be read. This information may be set-off from the surrounding text, but is always preceded by a bold title in capital letters:

### Note

**Note:** Presents additional, helpful, noncritical information that you can use.

### Warning

---

**Warning:** Presents information to warn you of a potentially hazardous situation in which there is a possibility of personal injury.

---

### Important

---

**Important:** Presents information to help you avoid an undesirable situation or provides additional information to help you understand a topic or concept.

---

### Caution

---

**Caution:** Presents information to identify a situation in which damage to software, stored data, or equipment could occur, thus avoiding the damage.

---

## Field Service

For Field Service requests, use this email address:  
n2csfs01@motorola.com

## General Safety

### Remember! . . . safety depends on you!

The following general safety precautions must be observed during all phases of operation, service, and repair of the equipment described in this manual. Failure to comply with these precautions or with specific warnings elsewhere in this manual violates safety standards of design, manufacture, and intended use of the equipment. Motorola, Inc. assumes no liability for the customer's failure to comply with these requirements. The safety precautions listed below represent warnings of certain dangers of which we are aware. You, as the user of this product, should follow these warnings and all other safety precautions necessary for the safe operation of the equipment in your operating environment.

### Ground the instrument

To minimize shock hazard, the equipment chassis and enclosure must be connected to an electrical ground. If the equipment is supplied with a three-conductor AC power cable, the power cable must be either plugged into an approved three-contact electrical outlet or used with a three-contact to two-contact adapter. The three-contact to two-contact adapter must have the grounding wire (green) firmly connected to an electrical ground (safety ground) at the power outlet. The power jack and mating plug of the power cable must meet International Electrotechnical Commission (IEC) safety standards.

**Note:** Refer to "*Grounding Guideline for Cellular Radio Installations*"—Motorola part no. *68P081150E62*.

### Do not operate in an explosive atmosphere

Do not operate the equipment in the presence of flammable gases or fumes. Operation of any electrical equipment in such an environment constitutes a definite safety hazard.

### Do not service or adjust alone

Do not attempt internal service or adjustment unless another person, capable of rendering first aid is present.

### Keep away from live circuits

Operating personnel must:

- not remove equipment covers. Only Factory Authorized Service Personnel or other qualified maintenance personnel may remove equipment covers for internal subassembly, or component replacement, or any internal adjustment

- not replace components with power cable connected. Under certain conditions, dangerous voltages may exist even with the power cable removed
- always disconnect power and discharge circuits before touching them

## Do not substitute parts or modify equipment

Because of the danger of introducing additional hazards, do not install substitute parts or perform any unauthorized modification of equipment. Contact Motorola Warranty and Repair for service and repair to ensure that safety features are maintained.

## Dangerous procedure warnings

Warnings, such as the example below, precede potentially dangerous procedures throughout this manual. Instructions contained in the warnings must be followed. You should also employ all other safety precautions that you deem necessary for the operation of the equipment in your operating environment.

Warning example:

---

**Warning:** Dangerous voltages, capable of causing death, are present in this equipment. Use extreme caution when handling, testing, and adjusting.

---

## Caring for the Environment

The following information is provided to enable regulatory compliance with the European Union (EU) Directive [2002/96/EC Waste Electrical and Electronic Equipment \(WEEE\)](#) when using Motorola equipment in EU countries.

## Disposal of Motorola equipment in EU countries



Please do not dispose of Motorola equipment in landfill sites.

In the EU, Motorola in conjunction with a recycling partner will ensure that equipment is collected and recycled according to the requirements of EU environmental law.

Please contact the Customer Network Resolution Center (CNRC) for assistance. The 24 hour telephone numbers are listed at

<http://mynetworksupport.motorola.com>

Select **Customer Network Resolution Center contact information**.

Alternatively if you do not have access to CNRC or the internet, contact the Local Motorola Office.

---

## Disposal of Motorola equipment in non-EU countries

In non-EU countries, dispose of Motorola equipment in accordance with national and regional regulations.

## Limitation of Liability

The Products are not designed, intended, or authorized for use as components in systems intended for surgical implant into the body; in other applications intended to support or sustain life; for the planning, construction, maintenance, operation or use of any nuclear facility; for the flight, navigation, communication of aircraft or ground support equipment; or in any other application in which the failure of the Product could create a situation where personal injury or death may occur. If CUSTOMER should use any Product or provide any Product to a third party for any such use, CUSTOMER hereby agrees that MOTOROLA is not liable, in whole or in part, for any claims or damages arising from such use, and further agrees to indemnify and hold MOTOROLA harmless from any claim, loss, cost or damage arising from such use.

EXCEPT AS SPECIFICALLY STATED ABOVE, THE PRODUCTS ARE PROVIDED "AS IS" AND MOTOROLA MAKES NO OTHER WARRANTIES EXPRESS, IMPLIED, STATUTORY, OR OTHERWISE REGARDING THE PRODUCTS. MOTOROLA SPECIFICALLY DISCLAIMS ANY IMPLIED WARRANTIES OF MERCHANTABILITY AND FITNESS FOR A PARTICULAR PURPOSE, OR ARISING FROM A COURSE OF DEALING OR USAGE OF TRADE.

Under no circumstances shall MOTOROLA be liable to CUSTOMER or any other party for any costs, lost revenue or profits or for any other special, incidental or consequential damages, even if MOTOROLA has been informed of such potential loss or damage. And in no event shall MOTOROLA's liability to CUSTOMER for damages of any nature exceed the total purchase price CUSTOMER paid for the Product at issue in the dispute, except direct damages resulting from patent and/or copyright infringement, which shall be governed by the "INDEMNITY" Section of this Agreement.

The preceding states MOTOROLA's entire liability for MOTOROLA's breach or failure to perform under any provision of this Agreement.

## Warranty Notification

Motorola guarantees to you, the original purchaser, the OEM module and accessories which you have purchased from an authorized Motorola dealer (the "Products"), to be in conformance with the applicable Motorola specifications current at the time of manufacture for a term of [1] year from date of purchase of the Product(s) (Warranty Term).

You must inform Motorola of the lack of conformity to the applicable specifications of any of the Products within a period of two (2) months from the date on which you detect a defect in material, workmanship or lack of conformity and in any event within a term not to exceed the Warranty Term, and must immediately submit the Product for service to Motorola's Authorized Repair or Service Center. Motorola shall not be bound by Product related statements not directly made by Motorola nor any warranty obligations applicable to the seller.

A list of the Motorola Call Center numbers is enclosed with this Product.

During the Warranty term, Motorola will, at its discretion and without extra charge, as your exclusive remedy, repair or replace your Product which does not comply with this warranty; or failing this, to reimburse the price of the Product but reduced to take into account the use you

have had of the Product since it was delivered. This warranty will expire at the end of the Warranty Term.

This is the complete and exclusive warranty for a Motorola OEM module and accessories and in lieu of all other warranties, terms and conditions, whether express or implied.

Where you purchase the product other than as a consumer, Motorola disclaims all other warranties, terms and conditions express or implied, such as fitness for purpose and satisfactory quality.

In no event shall Motorola be liable for damages nor loss of data in excess of the purchase price nor for any incidental special or consequential damages\* arising out of the use or inability to use the Product, to the full extent such may be disclaimed by law.

This Warranty does not affect any statutory rights that you may have if you are a consumer, such as a warranty of satisfactory quality and fit for the purpose for which products of the same type are normally used under normal use and service, nor any rights against the seller of the Products arising from your purchase and sales contract.

(\*including without limitation loss of use, loss of time, loss of data, inconvenience, commercial loss, lost profits or savings.

## How to Get Warranty Service?

In most cases the authorized Motorola dealer which sold and/or installed your Motorola OEM module and original accessories will honor a warranty claim and/or provide warranty service. Alternatively, for further information on how to get warranty service please contact either the customer service department of your service provider or Motorola's service centers, listed in Chapter 5.

## Claiming

In order to claim the warranty service you must return the OEM module and/or accessories in question to Motorola's Authorized Repair or Service Center in the original configuration and packaging as supplied by Motorola. Please avoid leaving any supplementary items like SIM cards. The Product should also be accompanied by a label with your name, address, and telephone number; name of operator and a description of the problem.

In order to be eligible to receive warranty service, you must present your receipt of purchase or a comparable substitute proof of purchase bearing the date of purchase. The phone should also clearly display the original compatible electronic serial number (IMEI) and mechanic serial number [MSN]. Such information is contained with the Product.

You must ensure that all and any repairs or servicing is handled at all times by a Motorola Authorized Service Center in accordance with the Motorola Service requirements

In some cases, you may be requested to provide additional information concerning the maintenance of the Products by Motorola Authorized Service Centers only, therefore it is important to keep a record of any previous repairs, and make them available if questions arise concerning maintenance.

---

## Conditions

This warranty will not apply if the type or serial numbers on the Product has been altered, deleted, duplicated, removed, or made illegible. Motorola reserves the right to refuse free-of-charge warranty service if the requested documentation can not be presented or if the information is incomplete, illegible or incompatible with the factory records.

Repair, at Motorola's option, may include reflashing of software, the replacement of parts or boards with functionally equivalent, reconditioned or new parts or boards. Replaced parts, accessories, batteries, or boards are warranted for the balance of the original warranty time period. The Warranty Term will not be extended. All original accessories, batteries, parts, and OEM module equipment that have been replaced shall become the property of Motorola. Motorola does not warrant the installation, maintenance or service of the products, accessories, batteries or parts.

Motorola will not be responsible in any way for problems or damage caused by any ancillary equipment not furnished by Motorola which is attached to or used in connection with the Products, or for operation of Motorola equipment with any ancillary equipment and all such equipment is expressly excluded from this warranty.

When the Product is used in conjunction with ancillary or peripheral equipment not supplied by Motorola, Motorola does not warrant the operation of the Product/peripheral combination and Motorola will not honor any warranty claim where the Product is used in such a combination and it is determined by Motorola that there is no fault with the Product. Motorola specifically disclaims any responsibility for any damage, whether or not to Motorola equipment, caused in any way by the use of the OEM module, accessories, software applications and peripherals (specific examples include, but are not limited to: batteries, chargers, adapters, and power supplies) when such accessories, software applications and peripherals are not manufactured and supplied by Motorola.

## What is Not Covered by the Warranty

This warranty is not valid if the defects are due to damage, misuse, tampering, neglect or lack of care and in case of alterations or repair carried out by unauthorized persons.

The following are examples of defects or damage not covered by this product warranty

1. Defects or damage resulting from use of the Product in other than its normal and customary manner.
2. Defects or damage from misuse, access to incompatible sources, accident or neglect.
3. Defects or damage from improper testing, operation, maintenance, installation, adjustment, unauthorized software applications or any alteration or modification of any kind.
4. Breakage or damage to antennas unless caused directly by defects in material or workmanship.
5. Products disassembled or repaired other than by Motorola in such a manner as to adversely affect performance or prevent adequate inspection and testing to verify any warranty claim.
6. Defects or damage due to range, coverage, availability, grade of service, or operation of the cellular system by the cellular operator.
7. Defects or damage due to moist, liquid or spills of food.
8. Control unit coil cords in the Product that are stretched or have the modular tab broken.

9. All plastic surfaces and all other externally exposed parts that are scratched or damaged due to customer normal use.

Depending on operating conditions and your usage habits, wear and tear might take place of components including mechanical problems related to Product housing, paint, assembly, sub-assemblies, displays and keyboards and any accessories which are not part of the Product's in-box configuration. The rectification of faults generated through wear and tear and the use of consumable items like batteries beyond their Optimum Performance Time as indicated in the product manual is considered to be your responsibility and therefore Motorola will not provide the free Warranty repair service for these items

## Installed Data

Please make and retain a note of all data you have inserted into your Product for example names, addresses, phone numbers, user and access codes, notes etc. before submitting your Product for a Warranty service as such data may be deleted or erased as part of the repair or service process.

Please note if you have downloaded material onto your product, these may be deleted or erased as part of the repair process or testing process. Motorola shall not be responsible for such matters. The repair or testing process should not affect any such material that was installed by Motorola on your Product as a standard feature.

## Out of Warranty Repairs

If you request Motorola to repair your Product any time after the Warranty term or where this warranty does not apply due to the nature of the defect or fault, then Motorola may in its discretion carry out such repairs subject to you paying Motorola its fees for such a repair or it may refer you to an authorized third party to carry out such repairs.

## Revision History

### Manual Number

6889192V27-D

### Manual Title

Module Hardware Description

### Version Information

The following table lists the manual version, date of version, and remarks about the version.

#### Revision History

Version	Date Issue	Remarks
<b>A</b>	January 1, 2006	Initial Release
<b>B</b>	April 1, 2006	Minor updates to Preface and Chapter 2
<b>C</b>	June 29, 2006	Removal of model numbers from the manual. Additional/updated regulatory issues. Reminder to EGPRS capabilities.
<b>D</b>	September 1, 2006	Updates to Chapter 2 - Hardware Interface Description, in the following paragraphs: RTC Mode, Power Consumption, Turning the G24 On, Power Supply Turn-on, Low Power Mode, Data on the Serial Interface, A/D Interface, Controls and Indicators Interface.



## Chapter 1: Introduction

---

The G24 is the newest member of Motorola's embedded cellular modules family.

Designed with quad band GSM capabilities, which supports all four GSM bands - 850/900/1800/1900 MHz, and with GPRS/EGPRS multislot class 10, G24 can operate on any GSM/GPRS/EGPRS network to provide voice and data communications.

The G24 is similar to a condensed cellular phone core, which can be integrated into any system or product that needs to transfer voice or data information over a cellular network. Thus, it significantly enhances the system's capabilities, transforming it from a standalone, isolated product to a powerful high-performance system with global communications capabilities.

The G24 is designed as a complete GSM communications solution with all the controls, interfaces and features to support a broad range of applications:

- A powerful audio interface
- A large set of indicators and control signals
- Several advanced power-saving modes
- A variety of serial communications solutions.

All these features and interfaces are easily controlled and configured using a versatile AT command interface that provides full control over the G24 operation.

The G24 control and indication interface extends its capabilities beyond GSM communications. This includes an A/D and GPIO interface, and a regulated output voltage for supplying external circuits. With these interfaces, the G24 can operate and control external applications and receive feedback from external environment and circuits.

The G24 interface design, using a single 70 pin board-to-board connector, through which all application interfaces are managed, facilitates fast and easy integration. It significantly shortens the development process, and minimizes the product's time to market.

The G24 is extremely compact in size with a slim mechanical design, which makes it space saving on the application board and easily fitted into any board design.

The advanced power supply management significantly reduces power consumption to a necessary minimum and prolongs battery life.

## Product Specifications

---

**Important:** For safety regulations and requirements, see “Regulatory Requirements” on page x, “Regulatory Statement (Safety)” on page x and “Antenna and Transmission Safety Precautions” on page x in “Preface” .

---

**Note:** Motorola reserves the right to change the specifications without prior notice.

**Table 1-1: Product Specifications**

Product Features	
<b>Operating systems:</b>	EGSM: 900/1800 MHz GSM: 850/1900 MHz
Physical Characteristics	
<b>Size (with 3 mm connector):</b>	45.2 x 24.4 x 6.5 mm
<b>Size (with 2.5 mm connector):</b>	45.2 x 24.4 x 6.0 mm
<b>Mounting:</b>	Two Ø2.4 mm holes
<b>Weight:</b>	10.1 grams

**Table 1-1: Product Specifications (Cont.)**

<b>Environmental</b>	
<b>Operational temperature:</b>	-20°C to +60°C
<b>Storage temperature:</b>	-40°C to +85°C
<b>Performance</b>	
<b>Operating voltage:</b>	3.3 - 4.2 V
<b>Current consumption:</b>	2.5 mA @ DRX9 (Sleep mode)
<b>Tx power:</b>	2 W, 850/900 MHz 1 W, 1800/1900 MHz
<b>Interfaces</b>	
<b>Connectors:</b>	Single 70-pin, board-to-board RF MMCX
<b>SIM Card:</b>	External SIM connectivity 3.0 V
<b>Serial Ports:</b>	UART: BR from 300 bps to 460800 bps Auto BR from 300 bps to 57600 bps USB: USB full-speed device specifications, Rev. 2.0
<b>Data Features</b>	
<b>GPRS:</b>	Multi-slot class 10 (4 Rx/2 Tx/5 Sum) Max Downlink BR 85.6 kbps Coding scheme CS1-CS4 Class B GSM 07.10 multiplexing protocol
<b>EGPRS (model depended)</b>	Multi-slot class 10 Data rates of 270 kSps Coding scheme CS5-CS9 Class E-2
<b>CSD:</b>	Max BR 14.4 kbps
<b>SMS:</b>	MO/MT Text and PDU modes Cell broadcast
<b>FAX Class 1</b>	
<b>Voice Features</b>	
<b>Telephony</b>	
<b>Digital audio</b>	
<b>Differential analog audio lines</b>	
<b>Vocoders</b>	EFR/HR/FR/AMR
<b>DTMF support</b>	
<b>Audio control:</b>	Echo suppression, noise suppression, side tone and gain control

**Table 1-1: Product Specifications (Cont.)**

<b>GSM Supplementary Service</b>
USSD Phase II
Call forwarding
Call hold, waiting and multiparty
Call diverting
Missed-call indicator
AOC
Call barring
<b>Character Set</b>
UTF8
UCS2
<b>Control/Status Indicators</b>
GSM/GPRS/EGPRS coverage
Wakeup
TX enable
Reset
Antenna Detect
<b>Features over RS232</b>
Embedded TCP/IP stack
<b>AT Command Set</b>
GSM 07.05
GSM 07.07
Motorola proprietary AT commands
<b>Accessories</b>
Firmware data loader
Data logger
Developer Kit

---

## Regulatory Approvals

The G24 module has been tested and approved under the standards and regulations listed below:

- FCC
- DOC
- R&TTE
- PTCRB
- IC
- CTIA
- FTA
- EMC

---

**Important:** The following paragraphs must be addressed by the integrator to ensure their host is in compliance to the g24 FCC grant and/or the FCC grant of the host device.

---

### CFR 47 Part 15.19 specifies label requirements

The following text may be on the product, user's manual, or container.

This device complies with Part 15 of the FCC Rules. Operation is subject to the following two conditions: (1) this device may not cause harmful interference, and (2) this device must accept any interference received, including interference that may cause undesired operation.

### CFR 47 Part 15.21 Information to user

The user's manual or instruction manual for an intentional or unintentional radiator shall caution the user that changes or modifications not expressly approved by the party responsible for compliance could void the user's authority to operate the equipment. In cases where the manual is provided only in a form other than paper, such as on a computer disk or over the Internet, the information required by this section may be included in the manual in that alternative form, provided the user can reasonably be expected to have the capability to access information in that form.

### CFR 47 Part 15.105 Information to the user

(b) For a Class B digital device or peripheral, the instructions furnished the user shall include the following or similar statement, placed in a prominent location in the text of the manual:

**Note:** This equipment has been tested and found to comply with the limits for a Class B digital device, pursuant to Part 15 of the FCC Rules. These limits are designed to provide reasonable protection against harmful interference in a residential installation. This equipment generates, uses and can radiate radio frequency energy and, if not installed and used in accordance with the instructions, may cause harmful interference to radio communications. However, there is no guarantee that interference will not occur in a particular installation. If this equipment does cause harmful interference to radio or television reception, which can be determined by turning the equipment off and on, the user is encouraged to try to correct the interference by one or more of the following

measures:

- Reorient or relocate the receiving antenna.
- Increase the separation between the equipment and receiver.
- Connect the equipment into an outlet on a circuit different from that to which the receiver is connected.
- Consult the dealer or an experienced radio/TV technician for help.

## Chapter 2: Hardware Interface Description

The following paragraphs describe in details the hardware requirements for properly interfacing and operating the G24 module.

### Architecture Overview

Figure 2-1 below illustrates the primary functional components of the G24.

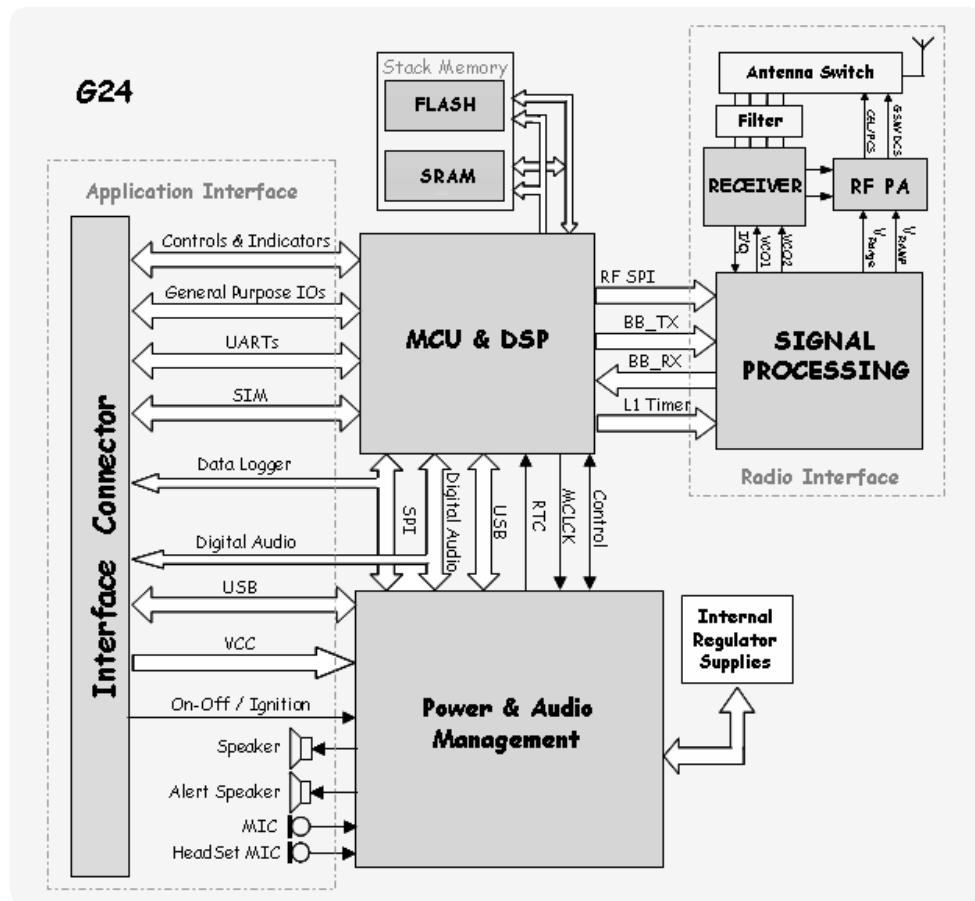

Figure 2-1: G24 Block Diagram

The G24 consists of the following blocks:

## Digital Block

- Micro-controller Unit (MCU) for system and user code execution.
- Digital Signal Processor (DSP) for voice and data processing.
- Serial communications interfaces.
  - USB driver interface
  - UART1
  - UART2
  - SPI - logger
  - SIM card
- Digital audio (PCM) bus interface.
- General purpose IO signals.

## Analog Block

- Power Management IC (PMIC).
  - Internal regulators
  - 1 external regulator for customer use
- Analog audio interface management.
  - Speaker, microphone
  - Alert speaker
  - Headset
- General purpose and dedicated A/D signals.
  - A/D
  - Voltage sensor
  - Temperature sensor
- Real Time Clock (RTC) subsystem.

## GSM Transceiver Block

- RF power amplifier.
  - 3 gain stages for the low GSM band and high GSM band
  - 850/900/1800/1900 MHz
- RF receiver, which includes LNAs, Mixers, VCOs, I/Q outputs and buffers.
- Signal processing IC for transmit and receive GSM data processing.
- FEM - Front End Module.
  - Includes a harmonic filter and antenna switch
- Filter - Quad-band SAW filter that selects the required receive band.

## Operating Modes

G24 incorporates several operating modes. Each operating mode is different in the active features and interfaces.

Table 2-1 summarizes the general characteristics of the G24 operating modes and provides general guidelines for operation.

**Table 2-1: G24 Operating Modes**

Mode	Description	Features
<b>Not Powered</b>	VCC supply is disconnected.	The G24 is Off. Any signals connected to the interface connector must be set low or tri-state.
<b>RTC Mode</b>	Valid VCC supply. RESET_N signal is enabled (low).	The G24 Interfaces are Off. Only the internal RTC timer is operating. Any signals connected to the interface connector must be set low or tri-stated.
<b>Idle Mode</b>	RESET_N signal is disabled (high). CTS_N and DSR_N signals are enabled (low).	The G24 is fully active, registered to the GSM network and ready to communicate. This is the default power-up mode.
<b>Sleep Mode</b>	RESET_N signal is high. CTS_N signal is disabled.	The G24 is in low power mode. The application interfaces are disabled, but, G24 continues to monitor the GSM network.
<b>CSD call or GPRS/EGPRS data</b>	RESET_N signal is high. TXEN_N signal is toggling.	A GSM voice or data call is in progress. When the call terminates, G24 returns to the last operating state (Idle or Sleep).

## Power Supply

The G24 power supply must be a single external DC voltage source of 3.3V to 4.2V. The power supply must be able to sustain the voltage level during a GSM transmit burst current surge, which may reach 2.0A.

The G24 interface connector has 8 contacts for the main power supply, as described in [Table 2-2](#). All these contacts must be used for proper operation.

**Table 2-2: Power Supply Signals**

Pin #	Signal Name	Description
1-4	GND	Main ground connection for G24 module.
5-8	VCC	DC supply input for G24 module. $V_{IN} = 3.3 \text{ V to } 4.2 \text{ V}$ $I_{RMS} = 550 \text{ mA}$ during multislot transmission $I_{MAX} = 2 \text{ A}$ during transmit bursts

## Power Supply Design

Special care must be taken when designing the power supply of the G24. The single external DC power source indirectly supplies all the digital and analog interfaces, but also directly supplies the RF power amplifier (PA). Therefore, any degradation in the power supply performance, due to losses, noises or transients, will directly affect the G24 performance.

The burst-mode operation of the GSM transmission and reception, draws instantaneous current surges from the power supply, which causes temporary voltage drops of the power supply level. The transmission bursts consume the most instantaneous current, and therefore cause the largest voltage drop. If the voltage drops are not minimized, the frequent voltage fluctuations may degrade the G24 performance.

[Figure 2-2](#) illustrates the power supply behavior during GSM transmission.

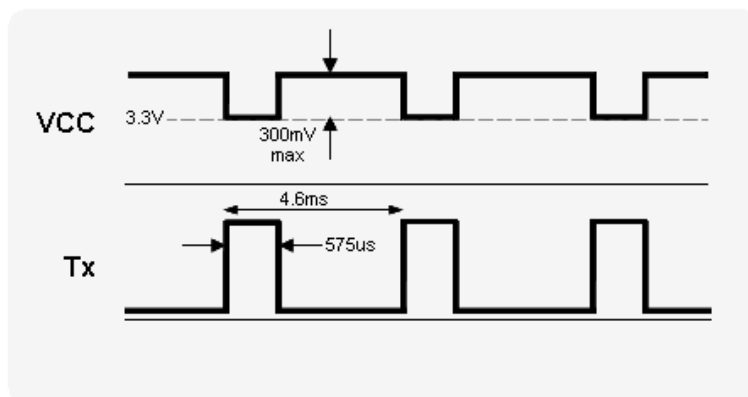

**Figure 2-2: Transmission Power Drops**

It is recommended that the voltage drops during a transmit burst will not exceed 300mV, measured on the G24 interface connector. In any case, the G24 supply input must not drop below the minimum operating level during a transmit burst. Dropping below the minimum operating level may result in a low voltage detection, which will initiate an automatic power-off.

To minimize the losses and transients on the power supply lines, it is recommended to follow these guidelines:

- Use a 1000 uF, or greater, low ESR capacitor on the G24 supply inputs. The capacitor should be located as near to the G24 interface connector as possible.
- Use low impedance power source, cabling and board routing.
- Use cabling and routing as short as possible.
- Filter the G24 supply lines using filtering capacitors, as described in [Table 2-3](#).

**Table 2-3: Recommended Power Supply Filtering**

Capacitor	Usage	Description
1000 uF	GSM Transmit current surge	Minimizes power supply losses during transmit bursts. Use maximum possible value.
10 nF, 100 nF	Digital switching noise	Filters digital logic noises from clocks and data sources.
8.2 pF, 10 pF	1800/1900 MHz GSM bands	Filters transmission EMI.
33 pF, 39 pF	850/900 MHz GSM bands	Filters transmission EMI.

## Power Consumption

[Table 2-4](#) specifies typical G24 current consumption ratings in various operating modes. The current ratings refer to the overall G24 current consumption over the VCC supply.

**Table 2-4: G24 Current Ratings**

Parameter	Description	Conditions	Min	Typ	Max	Unit
I <sub>OFF</sub>	RTC mode			75	85	μA
I <sub>IDLE</sub>	Idle mode			18		mA
I <sub>SLEEP</sub>	Low power mode	DRx 2 5 9		3.25 2.70 2.45		mA

Table 2-4: G24 Current Ratings (Cont.)

Parameter	Description	Conditions	Min	Typ	Max	Unit
$I_{\text{GSM-RMS}}$	Average current GSM voice - 1 TX slot 1 Rx slot	GSM850 PCL	5		305	mA
			10		165	
			15		120	
			19		110	
		EGSM900 PCL	5		305	
			10		165	
			15		120	
			19		110	
		DCS1800 PCL	0		225	
			5		150	
			10		115	
			15		107	
PCS1900 PCL	0		225			
	5		150			
	10		115			
	15		107			
$I_{\text{GPRS-RMS}}$	Average current GPRS Class 10 - 2 TX slot 3 Rx slot	GSM850 PCL	5		540	mA
			10		275	
			15		170	
			19		145	
		EGSM900 PCL	5		540	
			10		275	
			15		170	
			19		145	
		DCS1800 PCL	0		345	
			5		200	
			10		150	
			15		140	
PCS1900 PCL	0		345			
	5		200			
	10		150			
	15		140			
$I_{\text{EGPRS-RMS}}$	Average current EGPRS Class 10 - 2 TX slot 3 Rx slot	GSM850 PCL	8		339	mA
			14		185	
			19		144	
		EGSM900 PCL	8		328	
			14		185	
			19		148	
		DCS1800 PCL	2		260	
			9		167	
			15		151	
		PCS1900 PCL	2		260	
			9		169	
			15		151	

**Table 2-4: G24 Current Ratings (Cont.)**

Parameter	Description	Conditions	Min	Typ	Max	Unit
$I_{\text{GSM-MAX}}$	Peak current During TX slot	GSM850 PCL	5		2000	mA
			10		850	
			15		430	
			19		330	
		GSM900 PCL	5		2000	
			10		850	
			15		430	
			19		330	
		GSM1800 PCL	0		1350	
			5		615	
			10		380	
			15		330	
		GSM1900 PCL	0		1350	
			5		615	
			10		380	
			15		330	
$I_{\text{EGPRS-MAX}}$	Peak current EGPRS Class 10- 2 TX slot 3 RX slot	GSM850 PCL	8		1780	mA
			14		635	
			19		353	
		GSM900 PCL	8		1680	
			14		635	
			19		353	
		GSM1800 PCL	2		1200	
			9		489	
			15		367	
		GSM1900 PCL	2		1200	
			9		489	
			15		367	

## Power On/Off Operation

The G24 power on and off process includes two primary phases, which are indicated at the interface connector by the hardware output signals RESET\_N and CTS\_N.

The RESET\_N signal indicates whether G24 is powered on or off.

When this signal is enabled (low), G24 is powered-off. When it is disabled (high), G24 is powered-on.

The CTS\_N signal indicates the serial communications interface (UART) status. When this signal is high, the G24 serial interface is disabled. When it is low, the serial interface is enabled, and G24 is ready to communicate.

These same conditions apply to the CTS2\_N signal with regards to the second serial interface (UART2).

---

**Important:** Do not operate the G24 out of its electrical or environmental limits. Refer to the specifications chapter for details of these limits.

---

## Turning the G24 On

When the G24 power supply is stable above the minimum operating level and G24 is powered off, only the internal RTC timer is active.

When G24 is turned on, by any of the methods described below, it will first perform an automatic internal system-test, during which basic functions are verified. The system-test duration is typically 1600 milliseconds. When the system-test has completed G24 resumes normal operation.

During the internal system-test process G24 may toggle several interface signals, which are visible to the application. These signals do not represent any valid state or data, and should be ignored by the customer application until the system-test has completed.

## Power Supply Turn-on

When connecting the power supply for the first time, or when reconnecting it after a power supply loss, G24 will power-on. The G24 is turned-on automatically when external power is applied above the minimum operating level.

The G24 will power-off automatically, in case it is not powered-on by the ON\_N or IGN signals, after the internal system-test period (typically 1600ms) is completed.

If the ON\_N or IGN signals are asserted during that period, G24 will respond accordingly and continue to power-up normally.

The ON\_N and IGN signals will be active and responding only after the power supply to the G24 is stable above the minimum operating level. Therefore, the ON\_N and IGN signals must not be used for at least 100 milliseconds after applying power to G24.

Figure 2-3 illustrates the G24 power on and off upon application of a power supply, during which the ON\_N or IGN signals are not asserted.

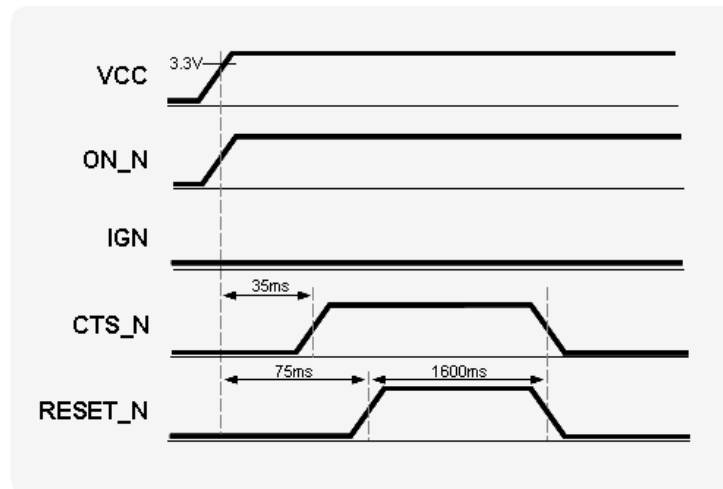

Figure 2-3: Power Supply Turn-on and Off

### Turning the G24 On Using ON\_N

The ON\_N input signal is set high by an internal pull-up resistor whenever a power supply is applied to G24. Therefore, it is recommended to operate this signal using an open collector/drain circuit connection.

Asserting the ON\_N signal low for a minimum of 500 milliseconds (0.5 seconds) and a maximum of 1.5 seconds will cause the G24 to turn-on.

Asserting the ON\_N signal low for more than 1.5 seconds may cause the G24 to interpret the signal as a power-off command, and turn off immediately after turning on.

Figure 2-4 illustrates the power-on process using the ON\_N signal.

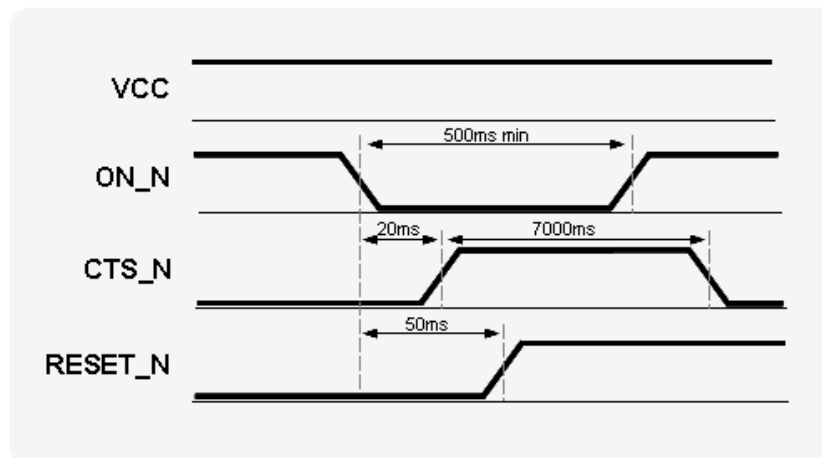

Figure 2-4: ON\_N Power On Timing

## Turning the G24 On Using IGN

The IGN input signal must be set low when not used. To turn on G24, this signal must be asserted high. The IGN signal must remain high for the duration of the G24 operation. G24 powers down when the IGN signal is returned to its low state.

**Important:** It is recommended to place a pull-down resistor in the customer application, on the IGN signal. A 100 kohm resistor, or less, is acceptable.

Figure 2-5 illustrates the power-on process using the IGN signal.

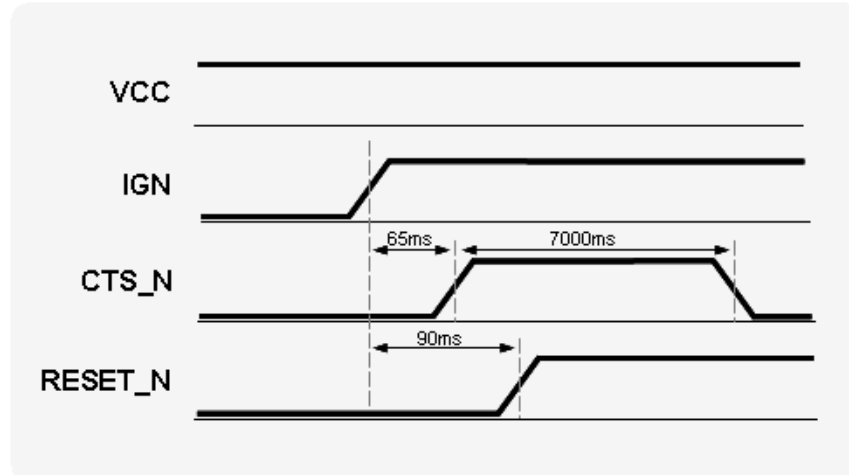

Figure 2-5: IGN Power On Timing

## Turning the G24 Off

There are several ways to turn the G24 off:

- Asserting the ON\_N signal low for a minimum of 2 seconds.
- Setting the IGN signal low.
- Low power automatic shut down.
- AT command.

## Turning the G24 Off Using ON\_N

The ON\_N signal is set high using an internal pull up resistor when power is applied to G24. Asserting the ON\_N signal low for a minimum of 2 seconds will turn G24 off. This will initiate a normal power-off process, which includes disabling of all applications interfaces (UART, SIM card, audio, etc.) and closing the network connection.

Figure 2-6 illustrates the power-off timings when using the ON\_N signal.

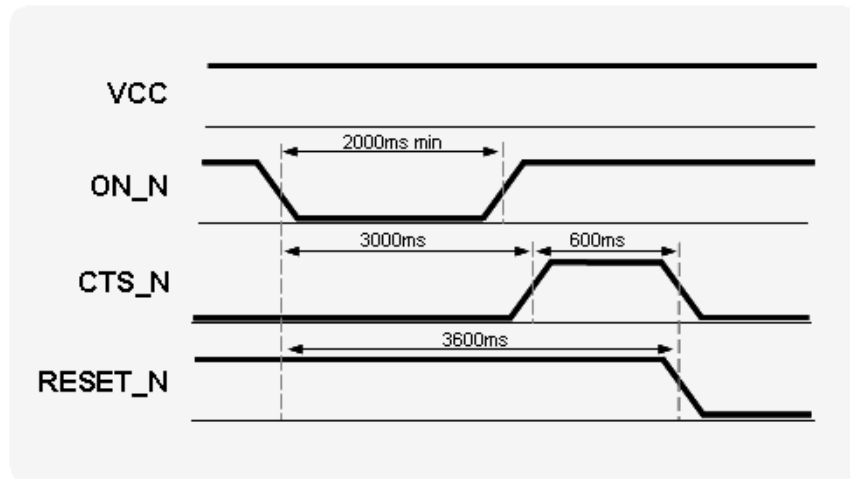

Figure 2-6: ON\_N Power Off Timing

### Turning the G24 Off Using IGN

The IGN signal may be used to power off G24 only if it was also used to power it on. When the IGN signal is set low, G24 will turn off. This will initiate a normal power-off process, which includes disabling of all applications interfaces (UART, SIM card, audio, etc.) and closing the network connection.

The IGN signal will not power off G24 before 30 seconds have elapsed since G24 was powered-on. This delay mechanism is implemented to protect G24 from unexpected transients on the IGN line during power up, particularly when applying vehicle cranking waveforms.

Figure 2-7 illustrates the power-off timings when using the IGN signal.

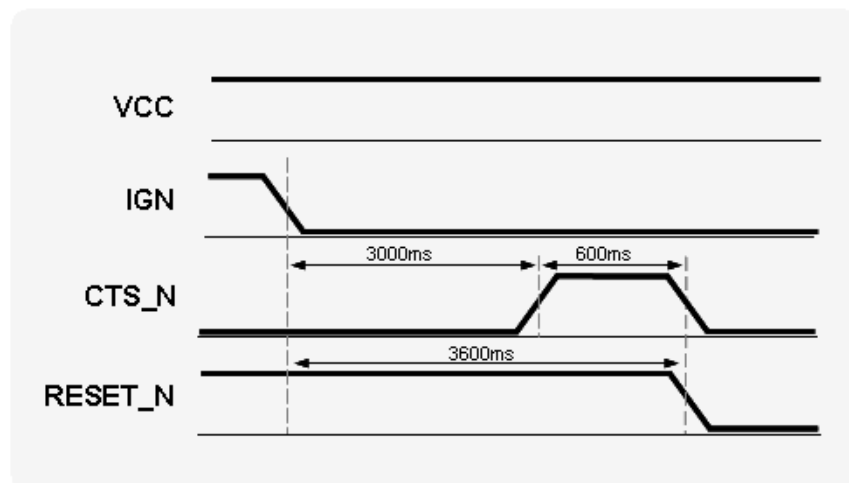

Figure 2-7: IGN Power Off Timing

## **Power Loss shut down**

A low power shut down occurs when G24 senses the external power supply is below the minimal operating limit. The module will respond by powering down automatically without notice.

This form of power-down is not recommended for regular use since the unexpected power loss may result in loss of data.

## **Turning the G24 Off Using AT+MRST**

The AT+MRST command initiates a G24 system reset operation, which powers off the G24. This command emulates the ON\_N signal operation for power off.

## Low Power Mode

The G24 incorporates an optional low power mode, called Sleep Mode, in which it operates in minimum functionality, and therefore draws significantly less current. During low power mode the G24 network connection is not lost. G24 continues to monitor the GSM network constantly for any incoming calls or data.

During low power mode, all of the G24 interface signals are inactive and are kept in their previous state, prior to activating low power mode. To save power, all the G24 internal clocks and circuits are shut down, and therefore serial communications is limited.

### Activating Low Power Mode

By default, the G24 powers on in Idle mode. In this mode the G24 interfaces and features are functional and the module is fully active.

Low power mode is activated by the AT\$24 command. The value set by this command determines the inactive state duration required by G24, in seconds, after which G24 will enter sleep mode.

For example:

AT\$24 = 1 activates low power mode after 1 second of inactivity.

AT\$24 = 5 activates low power mode after 5 seconds of inactivity.

AT\$24 = 0 disables low power mode (default).

Figure 2-8 illustrates the AT\$24 command operation.

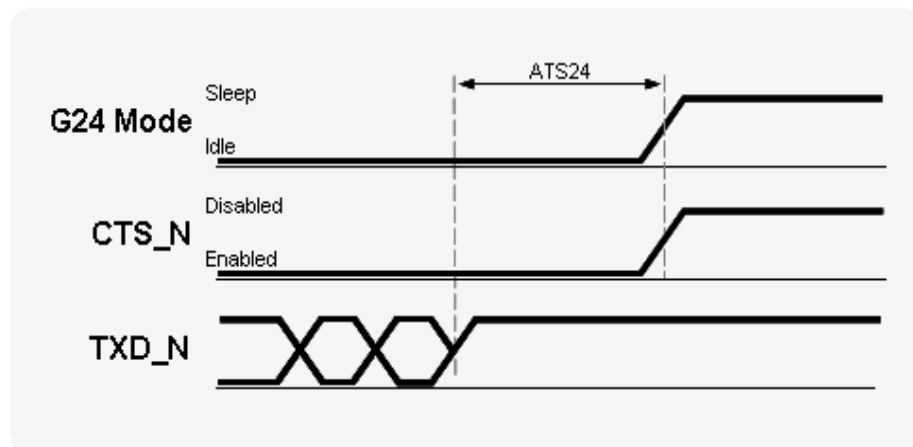

**Figure 2-8: AT\$24 Operation**

**Important:** G24 will not enter low power mode in any case when there is data present on the serial interface or incoming from the GSM network or an internal system task is running. Only when processing of any external or internal system task has completed, and G24 is inactive for the duration of AT\$24, it will enter low power mode.

**Important:** G24 will not enter low power mode when USB is operating. Connecting USB to the G24 will disable the low power mode operation.

## Serial Interface During Low Power Mode

During low power mode the G24 serial interfaces are disabled. This is indicated by the CTS signal high state.

The G24 wakes up periodically from low power mode to page the GSM network for any incoming calls or data. After this short paging is completed, G24 returns to low power mode. During this short awake period, the serial interfaces are enabled and communications with the module is possible.

The CTS\_N signal is alternately enabled and disabled synchronously with the network paging cycle. CTS\_N is enabled whenever G24 awakes to page the network. This indicates the G24 serial interfaces are active (see [Figure 2-9](#)).

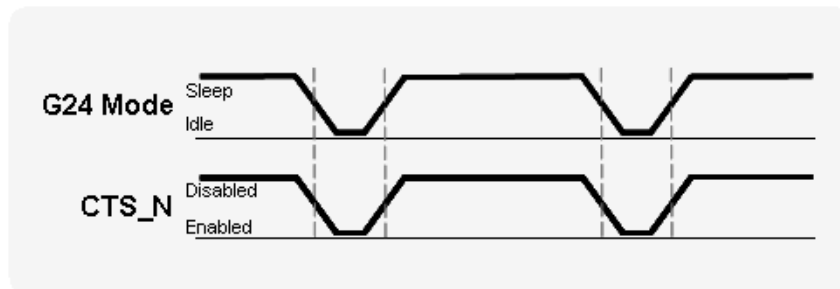

**Figure 2-9: CTS Signal During Sleep Mode**

The periodical enabling and disabling of the CTS\_N signal during low power mode can be controlled by the AT+MSCTS command.

Setting AT+MSCTS=1 permanently disables the serial interface during low power mode, even during a network page by G24. The CTS\_N signal is disabled, and therefore the serial interfaces are blocked.

## Terminating Low Power Mode

Terminating the low power mode, or wake-up, is defined as the transition of the G24 operating state from Sleep mode to Idle mode. There are several ways to wake-up G24 from low power mode as described below.

**Important:** During power saving mode the G24 internal clocks and circuits are disabled, in order to minimize power consumption. When terminating the power saving mode, and switching to Idle mode, G24 requires a minimal delay time to reactivate and stabilize its internal circuits before it can respond to application data. This delay is typically of 5 milliseconds, and is also indicated by the CTS\_N signal inactive (high) state. The delay guarantees that data on the serial interface is not lost or misinterpreted.

## Temporary Termination of Low Power Mode

Temporary termination of low power mode occurs when G24 switches from Sleep mode to Idle mode for a defined period, and then returns automatically to Sleep mode.

Low power mode may be terminated temporarily by several sources, some of which are user initiated and others are initiated by the system.

### Using the WKUPI\_N signal

The WKUPI\_N signal is an active low input, that is set high by default. By asserting this signal low the application can wake-up G24 from low power mode and switch to Idle mode.

G24 will remain in Idle mode, awake and fully active, as long as WKUPI\_N signal remains low. When this signal is disabled and set high again, G24 will return to Sleep mode automatically, according to the ATS24 settings (see [Figure 2-10](#)).

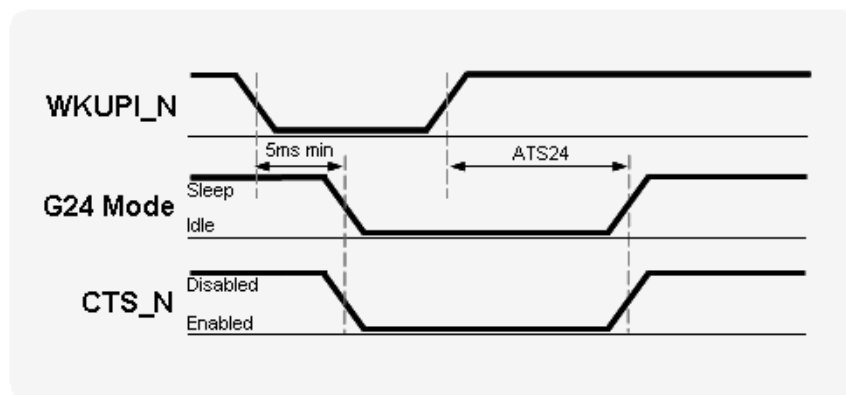

**Figure 2-10: WKUPI\_N Signal Operation**

The WKUPI\_N signal is the recommended method to temporarily wake-up G24 from low power mode. It provides the application full control of the G24 operating mode and guarantees that data on the serial interface will not be lost or misinterpreted.

The WKUPI\_N signal must be used to wake up G24 from low power mode if the serial interface has been disabled by the AT+MSCTS command.

### Incoming Network Data

During low power mode, G24 continues monitoring the GSM network for any incoming data, message or voice calls.

When G24 receives an indication from the network that an incoming voice call, message or data is available, it automatically wakes up from low power mode to alert the application. When G24 has completed to process all the tasks related to the incoming data, it will automatically return to low power mode according to the ATS24 settings.

Depending on the type of network indication and the application settings, G24 may operate in several methods, which are configurable by AT commands, to alert the application of the incoming data:

- Enable the WKUPO\_N signal to wake-up the application from low power.
- Send data to the application over the serial interface.
- Enable the serial interface's Ring Indicator (RI\_N) signal.

### Data on the Serial interface

While G24 is temporarily awake in Idle mode, data may be transmitted on the serial interface. In case data is being transmitted in any direction, G24 will not return to low power mode. This is regardless of the original wake-up reason or source. G24 will remain awake while data is transferred.

Only when the serial interface transfer is completed and the data has been processed, G24 will return to low power mode automatically, according to the ATS24 settings (see [Figure 2-11](#)).

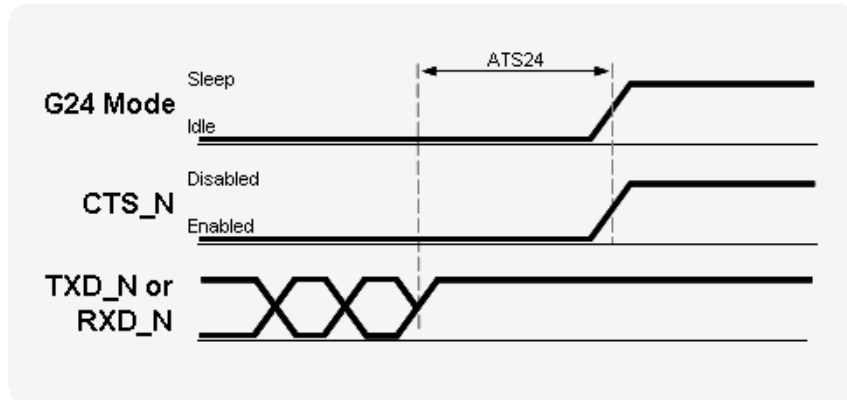

**Figure 2-11: Serial Interface Data**

### Permanent termination of Low Power Mode

The G24 low power mode is enabled and disabled by the ATS24 command.

To permanently terminate the G24 low power mode, the  $ATS24 = 0$  command must be used. Setting  $ATS24 = 0$  disables the currently active low power mode and switches G24 to Idle mode.

G24 will not return to low power mode until an  $ATS24 > 0$  commands is set again.

This command can be sent only when the serial interface is active.

In case the serial interface is disabled, it must first be activated before sending this command. To reactivate the serial interface, a temporary termination of the low power mode is required, as described in [“Temporary Termination of Low Power Mode”](#) on page 21.

Following the temporary low power mode termination, the serial interface will activate and the  $ATS24 = 0$  command can be received by G24.

## Real Time Clock

G24 incorporates a Real Time Clock (RTC) mechanism that performs many internal functions, one of which is keeping time. The RTC subsystem is embedded in the PMIC and operates in all of the G24 operating modes (Off, Idle, Sleep), as long as power is supplied above the minimum operating level.

The G24 time and date can be set using the following methods:

- Automatically retrieved from the GSM network.  
In case G24 is operated in a GSM network that supports automatic time zone updating, it will update the RTC with the local time and date upon connection to the network. The RTC will continue to keep the time from that point.
- Using the AT+CCLK command.  
Setting the time and date manually by this AT commands overrides the automatic network update.  
Once the time and date are manually updated, the RTC timer will keep the time and date synchronized regardless of the G24 operating state.

When the power supply is disconnected from G24, the RTC timer will reset and the current time and date will be lost. On the next G24 power-up the time and date will need to be set again automatically or manually.

## Serial Interfaces

G24 includes three completely independent serial communications interfaces, which may be used by the application for several purposes.

### Primary UART (UART1)

The G24 primary UART is a standard 8-signal bus. The primary UART is used for all the communications with G24 - AT commands interface, GPRS/EGPRS data and CSD data, programming and software upgrades.

The UART signals are active low CMOS level signals. For standard RS232 communications with a PC, an external transceiver is required.

G24 is defined as a DCE device, and the user application is defined as the DTE device. These definitions apply for the UART signals naming conventions, and the direction of data flow, as described in [Figure 2-12](#).

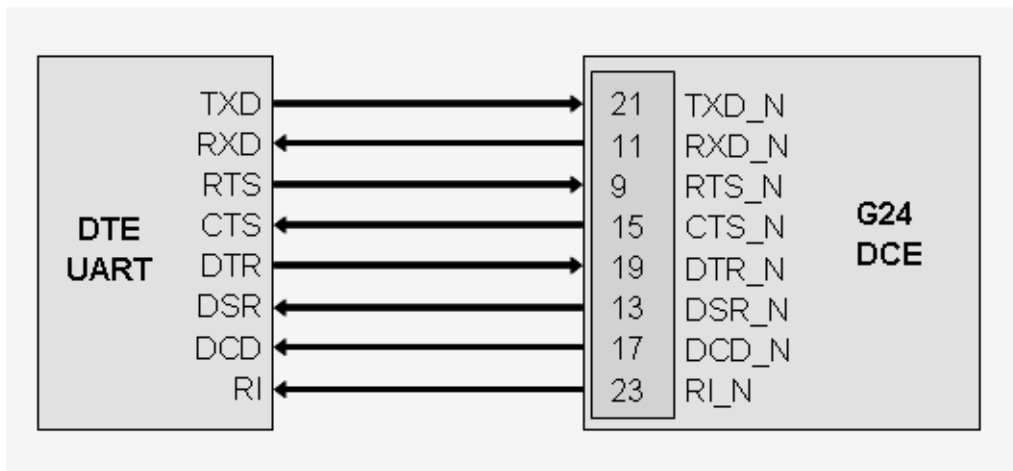

**Figure 2-12: UART1 Interface Signals**

The G24 primary UART supports baud rates 300, 600, 1200, 2400, 4800, 9600, 19200, 38400, 57600, 115200, 230400 and 460800 bps.

Auto baud rate detection is supported for baud rates up to 57600 bps.

All flow control handshakes are supported: hardware, software, or none.

Parity bit and Stop bit definitions are also supported.

The UART default port configuration is 8 data bits, 1 stop bit and no parity, with hardware flow control and auto baud rate detect enabled.

---

**Important:** The G24 UART will not send data over the serial interface in case the DTR\_N and/or RTS\_N input signals are disabled (set high). Therefore, regardless of the handshake method, it is still required to enable these signals for proper operation, by asserting them low.

---

## Secondary UART (UART2)

The secondary UART is a 4-signal interface, which only provides data and flow control signals. The secondary UART is designed, but not limited, to enhance the G24 capabilities by providing connectivity to external devices or applications that require serial communications, such as GPS receivers or Bluetooth wireless devices.

The secondary UART may also be used for standard serial communications, like the primary UART.

The UART signals are active low CMOS level signals. For standard RS232 communications with a PC, an external transceiver is required.

G24 is defined as a DCE device, and the user application is defined as the DTE device. These definitions apply for the UART signals naming conventions, and the direction of data flow, as described in [Figure 2-13](#).

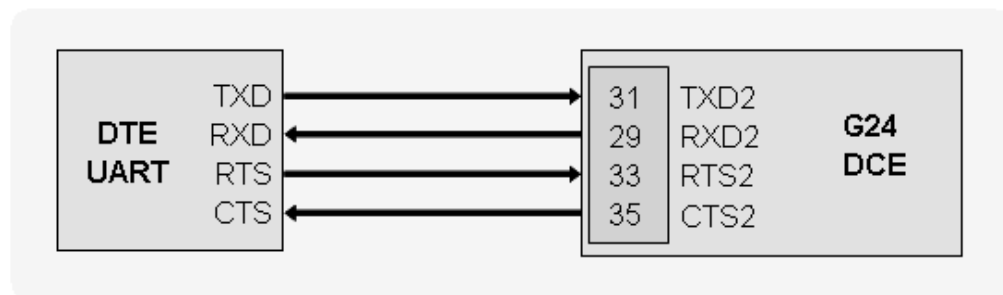

**Figure 2-13: UART2 Interface Signals**

## USB Interface

G24 incorporates a standard Universal Serial Bus (USB) interface.

The G24 USB electrical interface and protocol conform to the USB 2.0 full-speed specifications. G24 is defined as a USB device on the USB bus and does not support hub or host functionality.

USB may be used for standard communications with G24, as done through the UART interface.

---

**Important:** When USB is active, G24's low power mode cannot be operated.

---

The USB interface signals are shown in [Figure 2-14](#).

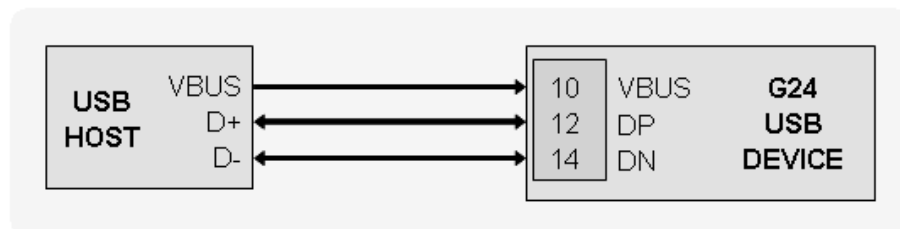

**Figure 2-14: USB Interface Signals**

## SIM Interface

The G24 incorporates a SIM interface, which conforms to the GSM 11.11 and GSM 11.12 standards, that are based on the ISO/IEC 7816 standard. These standards define the electrical, signaling and protocol specifications of a GSM SIM card.

G24 does not incorporate an on-board SIM card tray for SIM placement. The SIM must be located on the user application board, external to the G24. The G24 SIM interface includes all the necessary signals, which are routed to the interface connector, for a direct and complete connection to an external SIM.

G24 supports dynamic detection of the SIM card, through a dedicated SIM detection signal. G24 will detect a SIM card insertion or removal upon power up or during operation by the transitions on the SIM\_PD\_N signal.

### SIM Connection

Figure 2-15 illustrates a typical SIM interface connection to G24. This connection type is implemented on the G24 Developer Board, using an FCI SIM tray, PN 7111S1615A05.

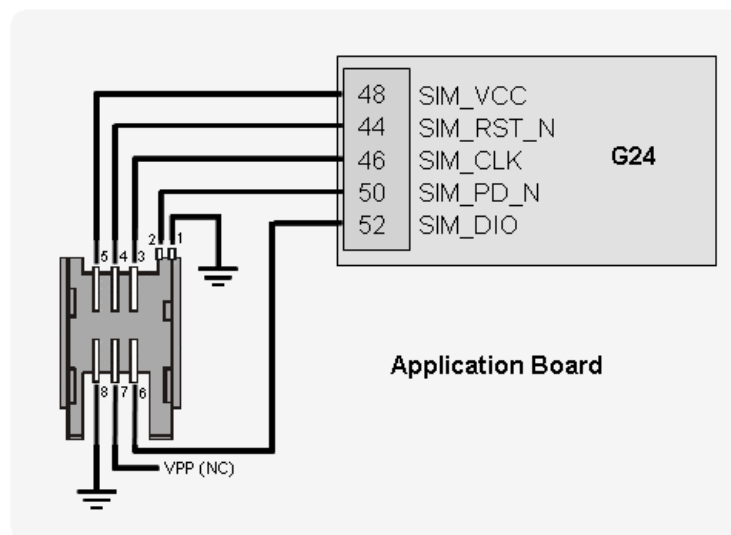

Figure 2-15: G24 SIM Interface

Table 2-5 details the SIM interface signals.

**Table 2-5: SIM Interface Signals**

Pin #	Signal Name	Description
48	SIM_VCC	2.85V Supply to the SIM
44	SIM_RST_N	Active low SIM reset signal
52	SIM_DIO	Serial input and output data

**Table 2-5: SIM Interface Signals (Cont.)**

Pin #	Signal Name	Description
46	SIM_CLK	Serial 3.25 MHz clock
50	SIM_PD_N	Active low SIM card presence detection

## SIM Design Guidelines

The SIM interface and signals design is extremely important for proper operation of G24 and the SIM card. There are several design guidelines that must be followed to achieve a robust and stable design that meets the required standards and regulations.

- Using the SIM detection signal, SIM\_PD\_N, is mandatory in case the SIM card is accessible to the user and may be removed during G24 operation. To avoid any damage to the SIM or G24, the SIM interface signals must be deactivated before the SIM card contacts are mechanically removed from the SIM tray contacts. Therefore, the SIM\_PD\_N detection signal must be disabled before the SIM is removed from its tray.
- The SIM should be located, and its signals should be routed, away from any possible EMI sources, such as the RF antenna and digital switching signals.
- The SIM interface signals length should not exceed 100 mm between the G24 interface connector and the SIM tray. This is to meet with EMC regulations and improve signal integrity.
- To avoid crosstalk between the SIM clock and data signals (SIM\_CLK and SIM\_DIO), it is recommended to rout them separately on the application board, and preferably isolated by a surrounding ground plane.
- The SIM card signals should be protected from ESD using very low capacitance protective elements (zener diodes, etc.).
- The G24 interface does not support SIM programming through the VPP signal. This signal should not be connected to G24.

## Audio Interface

The G24 audio interface supports several audio devices and operating modes.

The audio interface's operating modes, active devices, amplification levels and speech processing algorithms are fully controlled by the host application, through advanced programming options and a versatile AT commands set.

The G24 supports the following audio devices:

- Two single-ended and biased mono analog microphone inputs for use in a variety of modes.
- Two differential mono analog speaker outputs for use in a variety of modes.
- A digital serial interface using PCM coding.

Figure 2-16 shows the audio interface topology.

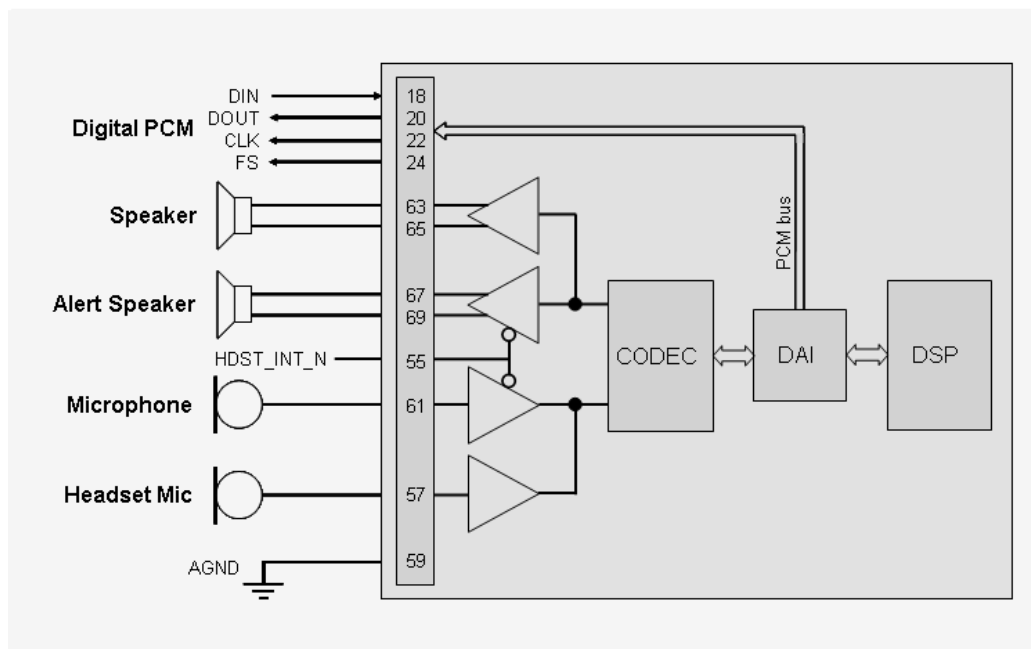

**Figure 2-16: Audio Interface Topology**

### Handset Microphone Port

The handset microphone port is the G24 power-up default active audio input for voice calls. It is located on pin 61 at the G24 interface connector, named MIC.

It is designed as a single-ended input and should be referenced to the G24 analog ground.

The microphone input includes all the necessary circuitry to support a direct connection to an external microphone device. It incorporates an internal bias voltage of 2.1V through a 2.2k $\Omega$  resistor, and has an impedance of 1k $\Omega$ .

Figure 2-17 shows the microphone circuit and Table 2-6 gives the microphone specifications.

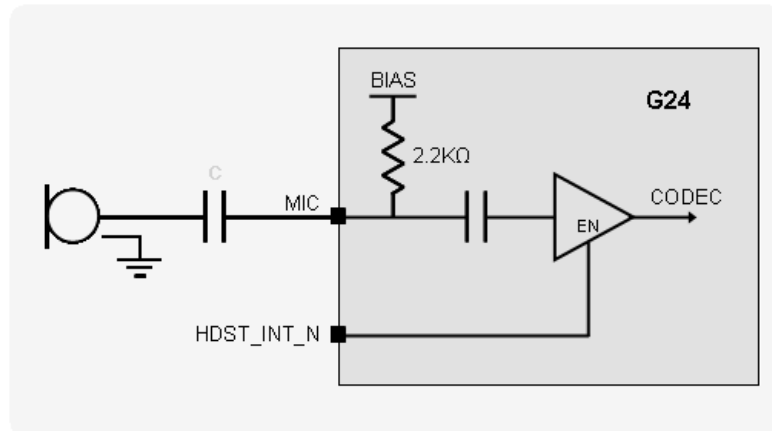

**Figure 2-17: Handset Microphone Circuit**

**Important:** The microphone circuit design depends on the type of microphone device. A series capacitor is required in case a passive microphone is used, or the application provides a separate bias voltage to an active microphone circuit. The internal G24 biasing circuit may also be used with an active microphone, which corresponds to the microphone port specifications.

**Table 2-6: Handset Microphone Port Specifications**

Parameter	Conditions	Min	Typ	Max	Unit
Input Voltage	No load AT+MMICG=0			2.0	V <sub>PP</sub>
Gain	Programmable in 1 dB steps	0		31	dB
AC Input Impedance			1		kΩ
Bias voltage	R <sub>BIAS</sub> = 2.2 kΩ I <sub>BIAS</sub> = 1 mA	2	2.1	2.2	V
Bias Current				1	mA

## Headset Microphone Port

The headset microphone port is designed for use with, but not limited to, a headset audio device. It is located at pin 57 on the G24 interface connector, named HDST\_MIC.

It is designed as a single-ended input and should be referenced to the G24 analog ground.

The microphone input includes all the necessary circuitry to support a direct connection to a headset microphone device. It incorporates an internal bias voltage of 2.1V through a 2.2kΩ resistor, and has an impedance of 1kΩ.

Figure 2-18 shows the microphone circuit and Table 2-7 gives the microphone specifications.

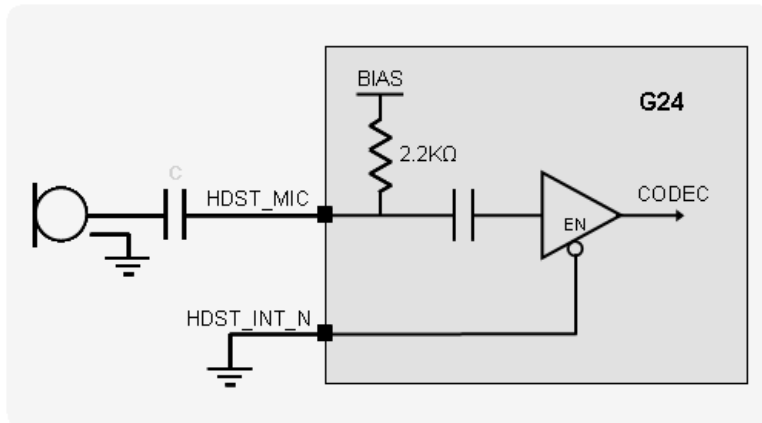

**Figure 2-18: Headset Microphone Circuit**

**Important:** The headset microphone circuit design depends on the type of microphone device. A series capacitor is required in case a passive microphone is used, or the application provides a separate bias voltage to an active microphone circuit. The internal G24 biasing circuit may also be used with an active microphone, which corresponds to the headset microphone port specifications.

**Table 2-7: Headset Microphone Port Specifications**

Parameter	Conditions	Min	Typ	Max	Unit
Input Voltage	No load AT+MMICG=0			2.0	V <sub>pp</sub>
Gain	Programmable in 1 dB steps	0		31	dB
AC Input Impedance			1		kΩ
Bias voltage	R <sub>BIAS</sub> = 2.2 kΩ I <sub>BIAS</sub> = 1 mA	2	2.1	2.2	V
Bias Current				1	mA

## Speaker Port

The analog speaker port is the G24 power-up default active output for voice calls and DTMF tones. It is located at pins 67 and 69 on the G24 interface connector, named SPKR\_N and SPKR\_P respectively.

It is designed as a differential output with 32Ω impedance, but may also be used as a single-ended output referenced to the G24 analog ground.

The speaker output is used for both the handset and the headset audio paths.

Figure 2-19 shows a differential speaker circuit, Figure 2-20 shows a single-ended speaker circuit and Table 2-8 gives the speaker specifications.

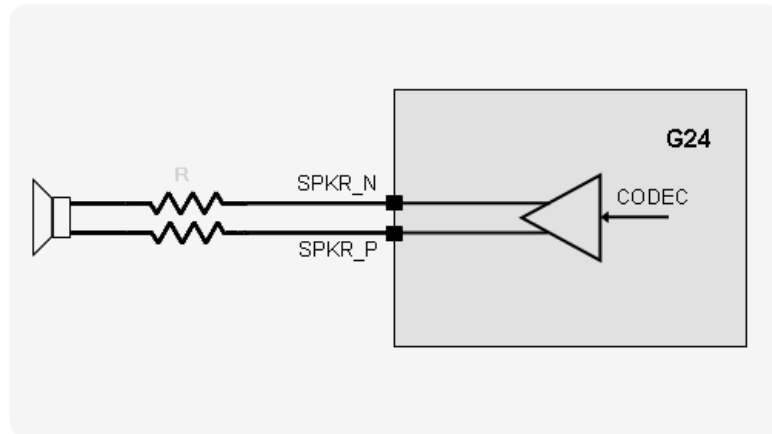

**Figure 2-19: Differential Speaker Circuit**

**Important:** For safety regulations it is important to place series resistors on the speaker output lines, as illustrated in Figure 2-19. The resistors value should be  $R = 0\Omega$  at the design stage, but may be changed to a different value during audio safety testing, in case speaker level limitation is required.

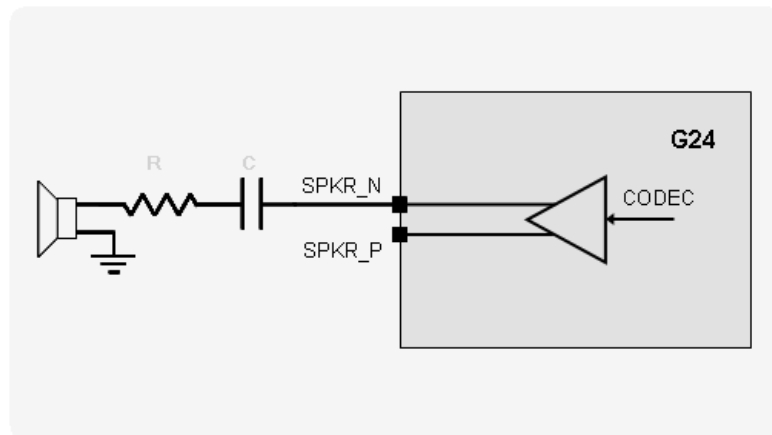

**Figure 2-20: Single-ended Speaker Circuit**

**Important:** When implementing a single ended speaker design, it is required to place a series capacitor and resistor on the speaker output line, as illustrated in [Figure 2-20](#). The capacitor should be of low tolerance with values of  $C = 10\text{-}22\ \mu\text{F}$ . The resistor value depends on the speaker application:

- For a handset device, the resistor value should be  $R = 0\ \Omega$  at the design stage, but may be changed to a different value during audio safety testing, in case speaker level limitation is required.
- For a headset device, safety regulations require the resistors value to be  $R \geq 2R_L\ \Omega$ , where  $R_L$  is the speaker impedance (e.g.  $32\ \Omega$ ).

For example, when using a  $32\ \Omega$  speaker the series resistance would be  $R \geq 64\ \Omega$ .

**Table 2-8: Speaker Port Specifications**

Parameter	Conditions	Min	Typ	Max	Unit
Output Voltage	No load Single ended			2.5	$V_{pp}$
Gain	Programmable in 3 dB steps	0		21	dB
AC Output Impedance			32		$\Omega$
DC Voltage			1.38		V
THD	32 $\Omega$ load 200 Hz - 20 kHz			0.1	%
Isolation	Speech, $f > 4\ \text{kHz}$	60			dB

## Headset Detection

The G24 operates by default in the basic audio mode with the handset audio path, for DTMF tones and speech, and the alert loudspeaker device, for rings and alert tones, active.

The headset path is an alternate audio path in basic mode. It is designed for, but not limited to, a personal hands-free audio device, a headset, using the headset microphone input device and the speaker output device. When this path is selected, the alert loudspeaker is disabled, and all the audio sounds are passed through to the headset path.

The HDST\_INT\_N signal is used to switch between handset and headset audio paths in basic audio mode. This signal is set high by default at power up. Asserting the HDST\_INT\_N signal low enables the headset audio path and disables the handset and alert paths. Setting this signal high will disable the headset path and enable the handset and alert audio paths.

The G24 supports dynamic switching between the handset and headset audio paths, during operation and call handling.

**Important:** The HDST\_INT\_N signal does not operate in advanced audio mode. This signal's functionality is overridden by the AT+MAPATH command settings.

## Alert Loudspeaker Port

The alert loudspeaker is the default G24 power-up ringer. It is used for, but not limited to, sounding the G24 alerts, melodies, and rings. It is located at pins 63 and 65 on the G24 interface connector, named ALRT\_N and ALRT\_P respectively.

It is designed with an internal amplifier supplied directly from VCC, which supplies 0.5W to the audio device. It may also be used as a single-ended output referenced to the G24 analog ground.

Figure 2-21 shows the alert loudspeaker circuit and Table 2-9 gives the loudspeaker specifications.

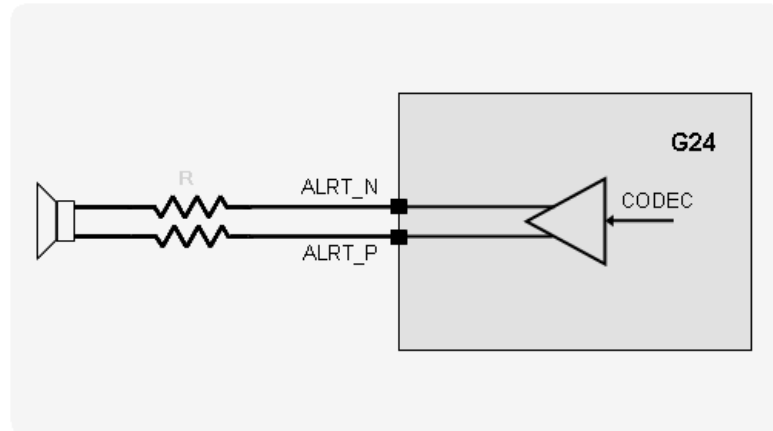

Figure 2-21: Differential Loudspeaker Circuit

**Important:** For safety regulations it is important to place series resistors on the alert output lines, as illustrated in Figure 2-21. The resistors value should be  $R = 0\Omega$  at the design stage, but may be changed to a different value during audio safety testing, in case that alert level limitation is required.

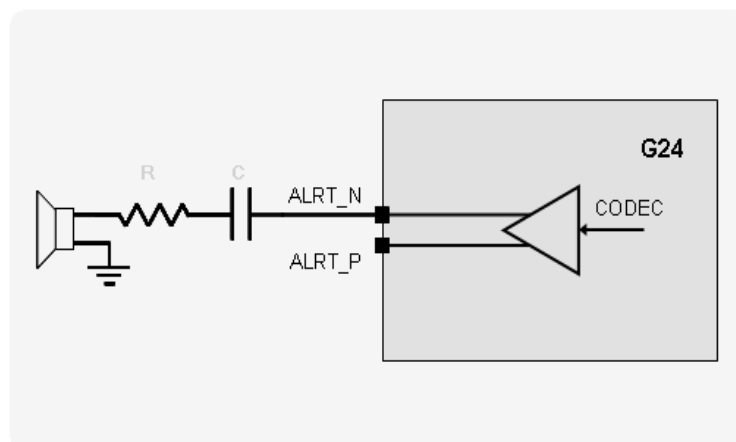

Figure 2-22: Single-ended Loudspeaker Circuit

**Important:** When implementing a single ended loudspeaker design, it is required to place a series capacitor and resistor on the alert output line, as illustrated in [Figure 2-22](#). The capacitor should be of low tolerance with values of  $C = 10\text{-}22\ \mu\text{F}$ . The resistor value should be  $R = 0\ \Omega$  at the design stage, but may be changed to a different value during audio safety testing, in case that alert level limitation is required.

**Table 2-9: Alert Port Specifications**

Parameter	Conditions	Min	Typ	Max	Unit
Output Voltage	No load Single ended			3.5	$V_{pp}$
Gain	Programmable in 3 dB steps	0		21	dB
AC Output Impedance			8		$\Omega$
DC Voltage			$V_{CC}/2$		V
THD	8 $\Omega$ load 200 Hz - 20 kHz		0.1	3	%
Isolation		60			dB

## Digital Audio Interface

The G24 digital audio interface is a serial Pulse Code Modulation (PCM) bus, which uses linear 2's compliment coding. G24 is the PCM bus master, supplying the clock and sync signals to the application.

The G24 digital interface is a 4 signal PCM bus, which includes a bit clock output signal for the bus timing, a frame sync output signal for audio sampling timing, and serial data input and output signals.

**Important:** The PCM bus signals are shared internally by the G24 analog audio interface and the digital audio interface. Therefore, when using the analog audio interface the PCM bus signals are active but must not be connected at the interface connector. The PCM bus is allocated, by default at power up, to the analog audio interface. Only after switching to digital audio mode, the PCM interface bus may be connected.

**Important:** The PCM bus is designed with a break-before-make switching configuration when transmitting between analog and digital audio modes. Therefore, the hardware interface connection to the PCM bus signals must be disconnected prior to switching between audio modes with the `AT+MADIGITAL` command.

The digital audio interface supports 4 types of audio data formats, which define the PCM bus configuration and data rates:

- Voice band audio - Intended for speech during voice calls and for mono rings and alerts.
- Stereo audio - Includes 3 audio formats that support high quality stereo ring tones and alerts.

The PCM bus configuration is defined by the audio data format that is sounded through the digital audio path, as described in [Table 2-10](#).

**Table 2-10: Digital Audio modes**

Audio Mode	Frame Sync Sampling	Bit Clock	AT+CRTT Tones
Voice	8 kHz	520 kHz	
Mono tones	8 kHz	520 kHz	6 - 9 (7 default)
Stereo low tones	20.05 kHz	705 kHz	12 - 38, 40 - 46
Stereo mid tones	32 kHz	1024 kHz	48 - 49
Stereo high tones	44.1 kHz	1.4 MHz	10, 11, 39, 47

## Voiceband Audio

This digital voice audio format is used for speech during voice calls and for mono rings and alerts.

The PCM bus signal's configuration for voiceband audio is:

- PCM\_CLK - 520 kHz serial clock
- PCM\_FS - 8 kHz bit-wide frame-sync
- PCM\_DOUT - 13-bit linear audio data output
- PCM\_DIN - 13-bit linear audio data input

The analog audio is sampled at an 8 kHz rate and converted to linear 13-bit serial PCM audio data. The serial data is transferred on the PCM bus in 16-bit word format, which includes 13 sampled data bits, and 3 added zero value bits.

The 16-bit serial data is transferred in both directions after each sync signal's falling edge. The sync signal pulse duration is one clock period, after which the serial data is transferred in both directions for 16 consecutive clock periods.

Following the 16-bit data transfer, the serial input and output data signals inactivate until the next sync pulse, which occurs every 125  $\mu$ S (8 kHz). It is recommended the serial data signals will be High-Z during the inactive period.

---

**Important:** In digital audio mode the input and output gains cannot be controlled by AT commands.

---

Figure 2-23 illustrates the PCM bus format of the voiceband audio configuration.

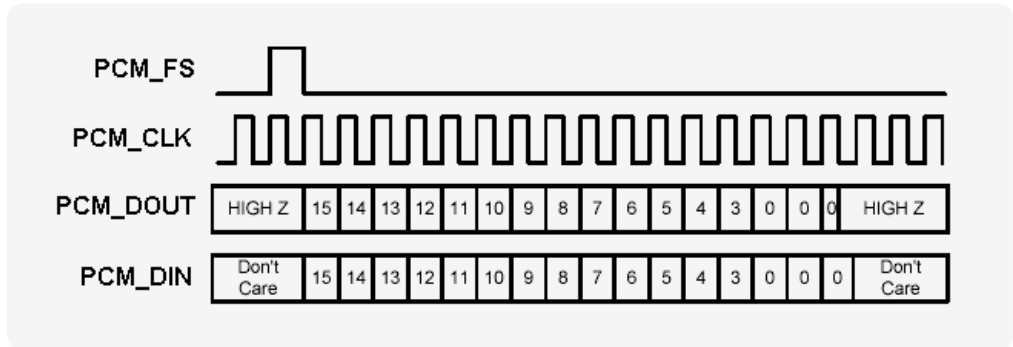

Figure 2-23: Voiceband Mode PCM Bus Coding Format

### Stereo Audio

The digital stereo audio format is used for sounding stereo ring tones and alerts. It incorporates 3 modes of operation that support the different audio sampling rates, which are provided by G24 as ring tone melodies. The available ring tones may be selected by the AT+CRTT command.

The PCM bus signal's configuration for stereo ring tones and alerts is:

- PCM\_CLK - 705 kHz - 1.4 MHz serial clock
- PCM\_FS - 22.05 kHz - 44.1 kHz word-wide frame-sync
- PCM\_DOUT - 16-bit linear audio data output
- PCM\_DIN - Disabled

Figure 2-24 illustrates the PCM bus format of the stereo audio configurations.

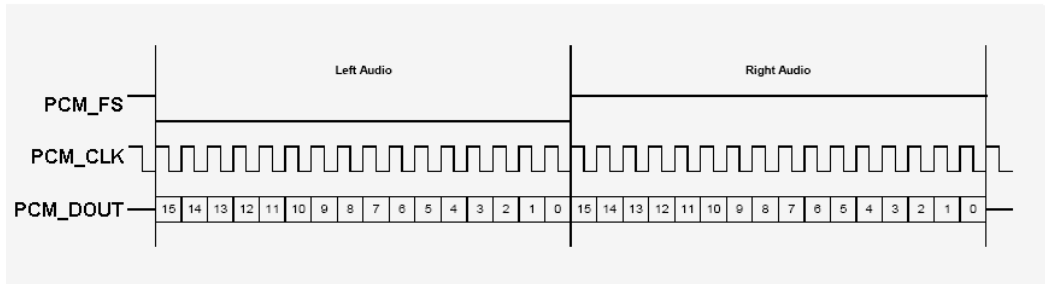

Figure 2-24: Stereo Mode PCM Bus Coding Format

### Operating Modes

The G24 audio interface includes 2 modes of operation. Each operating mode defines the audio input and output devices to be used for each audio sound type and their programmable settings.

#### Basic Mode

Basic audio mode is the G24 default power-up audio configuration. Several audio paths are available in this mode, and their settings can be programmed through the AT command set.

Table 2-11 describes the available audio paths in Basic mode.

**Table 2-11: Basic Mode Audio Paths**

Audio Path	Input Signal	Output Signal	Description
Handset	MIC	SPKR_N, SPKR_P	Default audio path for speech and DTMF tones.
Headset	HDST_MIC	SPKR_N, SPKR_P	Alternate path for headset device. Enable by setting HDST_INT_N interface signal low.
Alert		ALRT_N, ALRT_P	Default alert and ringer loudspeaker output device.
Digital	PCM_DIN	PCM_DOUT	Enable digital path by AT+MADIGITAL=1

## Advanced Mode

Advanced audio mode utilizes G24's unique set of AT commands for advanced audio programming. The expanded AT command set enables to define a specific audio path and setting, which are not part of the default configuration, for each type of audio sound (speech, DTMF tones, rings and alerts).

Unlike basic audio mode, which provides predefined audio paths, the advanced audio mode provides full control over the G24 audio interface and its parameters, and differentiates between each type of audio sound.

Table 2-12 describes the advanced mode audio programming features. These features are only a part of the complete advanced audio AT command set.

**Table 2-12: Advanced Mode Commands**

Command	Description
AT+MAPATH	Sets the input device for voice, and the output devices for voice, DTMF tones, rings and alerts.
AT+MAFEAT	Enables and disables the speech processing algorithms - Echo suppression, noise suppression and sidetone.
AT+MAVOL	Sets the gain (amplification) level of the selected analog output device.
AT+MMICG	Sets the gain (amplification) level of the selected analog input device.
AT+MADIGITAL	Switches between analog and digital audio paths.

## Audio Programming Interface

The G24 incorporates a unique audio programming interface, through AT commands, which controls the following audio features:

- Audio Path - Defines the input and output devices for speech, DTMF tones, rings and alerts.
- Audio Gain - Defines the amplification (gain) level for input and output audio devices.
- Audio Algorithm - Defines the speech processing features for voice calls.

Figure 2-25 describes the audio programming interface options, which are defined by AT commands.

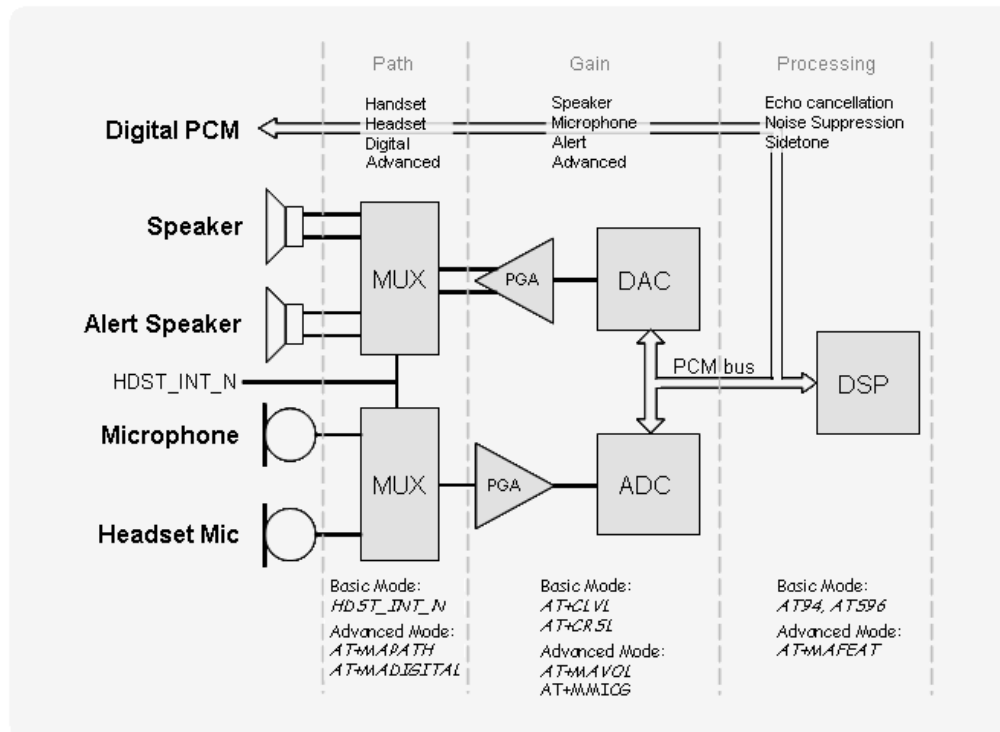

Figure 2-25: Audio Programming Interface

## Audio Algorithms

The G24 audio interface features advanced speech processing algorithms for echo suppression, noise suppression and side-tone feedback

Enabling or disabling the algorithms can be configured separately for each audio path and operating mode through the AT command interface.

The G24 also supports full rate (FR), half rate (HR), enhanced full rate (EFR) and adaptive multi-rate (AMR) speech coding algorithms, which are used by the GSM network. These algorithms are configured and operated by the GSM network provider.

Table 2-13 gives the speech processing features.

**Table 2-13: Speech Processing Features**

Feature	AT Command		Default Setting	Description
	Basic	Advanced		
Echo Suppression	ATS96	AT+MAFEAT	Disabled	Controls the echo and noise suppression.
Noise Suppression				
Sidetone	ATS94	AT+MAFEAT	Enabled	Controls the sidetone.

## Gain Control

The amplification (gain) level for each input and output device can be configured through AT commands. Both basic and advanced audio modes provide AT commands to set the desired gain levels for each audio path and audio sound type.

Table 2-14 gives the gain control features.

**Table 2-14: Gain Control Features**

Device	Gain Command		Default Gain	Description
	Basic	Advanced		
Microphone	AT+MMICG	AT+MMICG	3	Sets input speech gain level.
Headset Microphone			3	Sets input speech gain level.
Speaker	AT+CLVL	AT+MAVOL	4	Sets voice and DTMF gain.
Alert Speaker	AT+CRSL		4	Sets rings and alerts gain.

Gain levels for the input and output devices, which correspond to the values set by the AT commands, are described in Table 2-15 and Table 2-16.

**Table 2-15: Speaker Port Gains for Speech**

AT Command Value	0dBm0 Gain Level (dB)	0dBm0 Output Level (mV <sub>RMS</sub> )
0	-36	12
1	-33	17.5
2	-30	25
3	-27	34.5

**Table 2-15: Speaker Port Gains for Speech (Cont.)**

AT Command Value	0dBm0 Gain Level (dB)	0dBm0 Output Level (mV <sub>RMS</sub> )
4	-24	50
5	-21	70
6	-18	100
7	-15	140

**Table 2-16: Microphone and Headset Microphone Port Gains**

AT Command Value	0dBm0 Input Level (mV <sub>RMS</sub> )	Maximum Input Level (mV <sub>RMS</sub> )
0	87	350
...	...	...
3	63	250
...	...	...
16	15	55
...	...	...
31	4	11

## Audio Design

The audio quality delivered by G24 is highly affected by the application audio design, particularly when using the analog audio interface. Therefore, special care must be taken when designing the G24 audio interface. Improper design and implementation of the audio interface will result in poor audio quality.

Poor audio quality is a result of electrical interferences, or noises, from circuits surrounding the audio interface. There are several possible sources for the audio noise:

- Transients and losses on the power supply
- EMI from antenna radiations
- Digital logic switching noise

Most of the audio noise originates from the GSM transmit burst current surges (217 Hz TDMA buzz), which appear on the main power supply lines and antenna, but also indirectly penetrate the internal application's supplies and signals. The noises are transferred into the G24's audio circuits through the microphone input signals and then are amplified by the G24's internal audio amplifiers.

To minimize the audio noise and improve the audio performance the microphone and speaker signals must be designed with sufficient protection from surrounding noises.

The following guidelines should be followed to achieve best audio performance:

- Reference the microphone input circuits to the G24 AGND interface signal.
- If using single-ended audio outputs, they should be referenced to the G24 AGND interface signal.
- Keep the audio circuits away from the antenna.
- Use RF filtering capacitors on the audio signals, as described in [Table 2-3](#).
- The audio signals should not be routed adjacent to digital signals.
- Isolate the audio signals by a surrounding ground plane or shields.
- Filter internal supplies and signals that may indirectly affect the audio circuits, from noises and voltage drops.

## **Analog Ground**

The G24 interface incorporates a dedicated analog ground contact, AGND pin 59, which is internally connected to the G24's ground. The AGND signal is intended to provide a separate ground connection for the application's external audio devices and circuits.

This signal provides an isolated ground connection directly from G24, which is separated from the noisy digital ground of the application. It is recommended to connect this signal to analog audio devices and circuits used by the application. Using a separate analog ground minimizes audio noises and improves the audio circuit's immunity from external interferences.

## A/D Interface

The G24 includes 5 Analog to Digital Converter (ADC) signals with 10-bit resolution, for environmental and electrical measurements. The ADC signals measure an analog DC voltage level on their inputs which is converted to a 10-bit digital value for further processing by G24 or the user application.

The A/D signals operation and reporting mechanism is defined by the AT+MMAD command. Each A/D can be defined to provide several reports:

- A single measurement.  
A single A/D measurement will take place and will be reported upon activation of the AT command.
- An automatic periodical measurement.  
The A/D measures its input signal at a rate that is defined by the user application. Every measurement will generate an unsolicited message over the serial interface.
- An automatic periodical measurement with predefined limits.  
The A/D measures its input signal at a rate that is defined by the user. The user also defines upper and/or lower limits for the A/D measurements. Each measurement is compared to these limits, and an unsolicited message is generated only if these limits are exceeded.

---

**Important:** In case the defined periodical measurement rate is equal to, or shorter than, the defined sleep mode delay settings (ATS24), G24 will not enter low power mode.

---

Table 2-17 below, lists the internal and external A/D signals provided by G24.

**Table 2-17: A/D Signals**

ADC Name	Description	Pin #	ADC #	Min	Max	Unit
VCC	Power Supply ADC	-	5	3.0	4.5	V
Temp	Temperature ADC	-	4	-30 (229)	70 (17)	°C (ADC)
ADC3	GPAD 3	47	3	0	2.3	V
ADC2	GPAD 2	43	2	0	2.3	V
ADC1	GPAD 1	37	1	0	2.3	V

### Power Supply A/D

The main power supply (VCC) is constantly monitored internally by the G24 through a dedicated A/D signal, which is not accessible on the interface connector.

The measured VCC level can be read and monitored by the user application through the AT+MMAD command, which returns the measured VCC level in Volts times 100.

For example, a measured supply level of 3.65 Volts will be presented as 365 by the MMAD command.

**Important:** During GSM transmissions the power supply may suffer voltage drops. This can cause frequent and wide changes in the power supply A/D measurements. This should be taken into account when designing and operating the G24 power supply A/D interface.

Table 2-18 gives the supply A/D specifications.

**Table 2-18: Supply A/D Specifications**

Parameter	Conditions	Min	Typ	Max	Unit
Measurement Range		3.0		4.5	V
Resolution			10		mV

## Temperature A/D

The G24 incorporates an internal temperature sensor circuit, which is used to monitor the operating temperature. The temperature is constantly monitored by G24 through a dedicated A/D signal, which is not accessible at the interface connector. Figure 2-26 shows the temperature A/D characteristics.

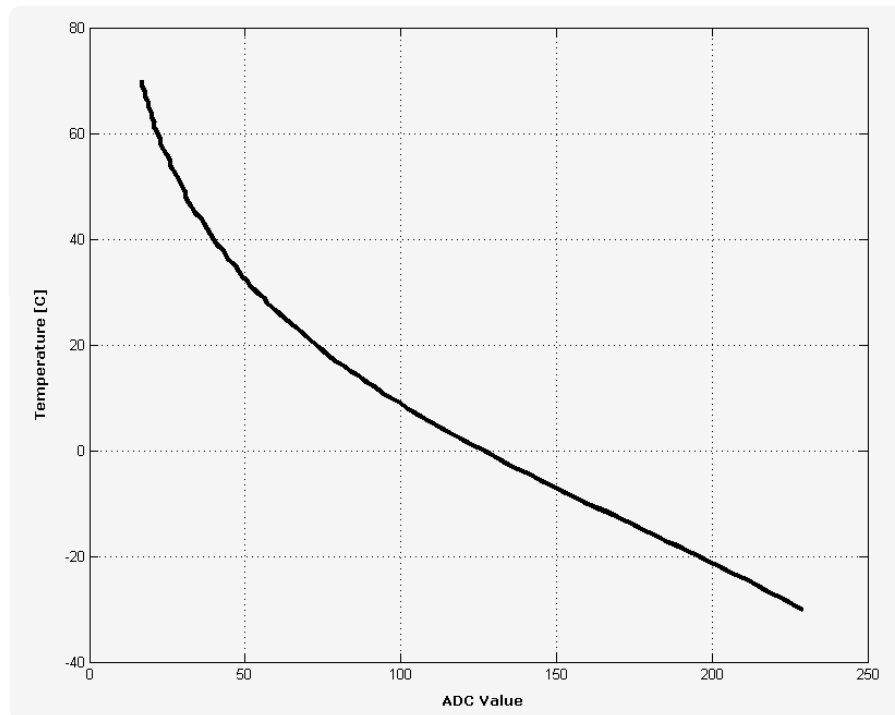

**Figure 2-26: Temperature A/D Characteristics**

The measured temperature level can be monitored by the user application through the AT+MMAD command, which returns a digital decimal value that represents the measured temperature level.

The actual temperature level (in degrees Celsius) can be derived from [Table 2-19](#):

**Table 2-19: Temperature Conversion Values**

Temperature (°C)	ADC Value	Temperature (°C)	ADC Value	Temperature (°C)	ADC Value
-30	229	4	114	38	43
-29	226	5	111	39	41
-28	223	6	108	40	40
-27	219	7	105	41	39
-26	216	8	102	42	38
-25	213	9	100	43	37
-24	210	10	97	44	36
-23	206	11	94	45	34
-22	203	12	92	46	33
-21	199	13	89	47	32
-20	196	14	87	48	31
-19	192	15	84	49	31
-18	189	16	82	50	30
-17	185	17	79	51	29
-16	182	18	77	52	28
-15	178	19	75	53	27
-14	175	20	73	54	26
-13	171	21	71	55	26
-12	168	22	69	56	25
-11	164	23	67	57	24
-10	160	24	65	58	23
-9	157	25	63	59	23
-8	153	26	61	60	22
-7	150	27	59	61	21
-6	146	28	57	62	21
-5	143	29	56	63	20
-4	140	30	54	64	20
-3	136	31	52	65	19
-2	133	32	51	66	19
-1	130	33	49	67	18
0	127	34	48	68	18
1	123	35	47	69	17
2	120	36	45	70	17
3	117	37	44		

A temperature level approximation can also be obtained using the following 5th order polynomial formula:

$$\text{Temp}[C] = -1.27e^{-9} \times \text{ADC}^5 + 8.91e^{-7} \times \text{ADC}^4 - 2.43e^{-4} \times \text{ADC}^3 + 3.89e^{-2} \times \text{ADC}^2 + 2.56 \times \text{ADC} + 103.30$$

Where ADC is the digital temperature value reported by the MMAD command.

Table 2-20 gives the temperature A/D specifications.

**Table 2-20: Temperature A/D Specifications**

Parameter	Conditions	Min	Typ	Max	Unit
Measurement Range		-30		70	°C
ADC Range	MMAD Value	229		17	ADC
Tolerance				5	%

## General Purpose A/D

The G24 provides 3 general purpose A/D (GPAD) signals for customer application use. Each A/D signal can monitor a separate external voltage and report its measured level independently to the application, through the AT command interface.

The GPAD signals measure a DC voltage level of 0 - 2.3 V, which is converted internally to a 10-bit digital value. The user application can monitor the A/D voltage level through the AT+MMAD command, which returns the measured DC level in Volts times 100.

For example, a measured analog DC level of 1.75 Volts will be presented as 175 by the MMAD command.

Table 2-21 gives the GPAD specifications.

**Table 2-21: GPAD Specifications**

Parameter	Conditions	Min	Typ	Max	Unit
Maximum Input Voltage	Operating range	-0.1		2.75	V
Measurement Voltage	ADC range	0		2.3	V
Resolution			10		mV

## Controls and Indicators Interface

The G24 incorporates several interface signals for controlling and monitoring the module's operation. The following paragraphs describes these signals and their operation.

Table 2-22 gives a description of the controls and indicators signals.

**Table 2-22: Controls and Indicators**

Connector Pin	Signal Name	Description
25	RESET_N	G24 system reset output indicator. When high, G24 is operating.
27	VREF	2.75V regulated output. Supplies external circuits up to 200mA.
26	WKUPO_N	Host application wake-up signal indicator.
41	ANT_DET	Antenna physical connection detect indicator.
49	GPRS/GSM	Network status indicator.
39	TXEN_N	Transmission burst indication.
28, 30, 32, 34, 36, 38, 40, 42	GPIO 1-8	General purpose IO signals for customer use.

### Reset

The RESET\_N output signal indicates the G24's operating status. This signal is set high after power up, when G24 is operating. It is set low when G24 is powered off.

When the RESET\_N signal is low, the G24 interface signals are disabled and do not represent any valid data or state. Furthermore, any input signals connected to the G24 interface must be disabled (tri-state) or set low when RESET\_N is low.

### VREF Reference Regulator

The G24 incorporates a regulated voltage output, VREF. The regulator provides a 2.75V output for use by the customer application. This regulator can source up to 200 mA of current to power any external digital circuits.

---

**Important:** The VREF regulator is powered from the G24's main power supply, and therefore any current sourced through this regulator originates from the G24 VCC supply. The overall VCC current consumed by G24 is directly affected by the VREF operation. The G24 current consumption rises with respect to the current sourced through VREF.

---

The VREF regulator incorporates 3 operating modes that are controlled by the AT+MVREF command. These modes define the regulator operating state relative to the G24's operating mode.

Figure 2-27 shows the VREF power-up timing.

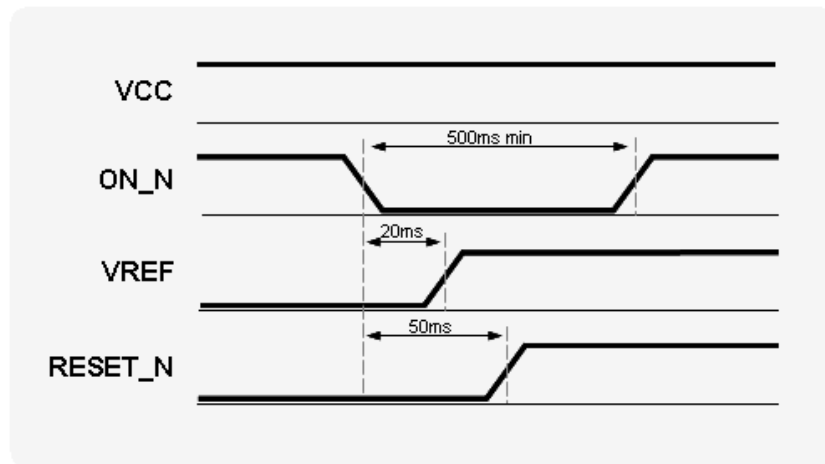

Figure 2-27: VREF Power-up Timing

### OFF Mode

In this mode the VREF regulator is disabled and its output drops to 0V, regardless of the G24 operating state.

### Standby Mode

The Standby operating mode is the default mode when G24 powers on. In this mode VREF follows the G24's operating state.

When the G24 is in low power mode, Sleep mode, the VREF regulator is also in a low power state. In this state the VREF regulated output is limited to providing only 2 mA of current maximum, while maintaining the 2.75V output level.

When G24 is in Idle mode, or wakes up temporarily from low power mode, the VREF regulator returns to full operation, supplying up to 200 mA.

### Active Mode

In this mode the VREF regulator is always fully active while G24 is operating, regardless of the G24 operating mode.

Table 2-23 gives the VREF specifications.

**Table 2-23: VREF Specifications**

Parameter	Conditions	Min	Typ	Max	Unit
V <sub>OUT</sub>	I <sub>OUT</sub> = 200 mA	-3%	2.75	+3%	V
I <sub>OUT</sub>	Active mode Standby mode		50	200 2	mA
Load regulation			0.27		mV/ mA
Line regulation				5	mV
PSRR	20 Hz - 20 kHz		60		dB

## Wakeup Out

Some applications incorporate their own power saving mode, in which they operate with minimal functionality, including disabling of interfaces and serial communications.

The wakeup-out (WKUPO\_N) signal is an active low output, which is designed to support a low power mode feature in the host application. This signal is used by G24 to indicate that it requires to communicate with the host application through the serial interface, due to an incoming call or data, or an unsolicited event. Applications that incorporate a low power mode should use this signal as an indication to switch from low power mode to normal operation, and activate the serial interface.

The wakeup-out mechanism, using the WKUPO\_N signal, is controlled by 2 AT commands (see Figure 2-28):

- **ATS102** - Defines the delay time in milliseconds that G24 will wait, after asserting the WKUPO\_N signal low, before sending data on the serial interface. This delay is required to allow the application enough time to reactivate from low power mode and switch to normal mode.  
 If ATS102=0, which is the default value, the WKUPO\_N signal and mechanism is disabled. In case the serial interface incorporates hardware flow control signals, the data will be sent according to their state, after the ATS102 delay time has expired.
- **ATS100** - Defines the application minimal wakeup duration, in seconds, for a single wakeup event. This time definition is required to avoid frequent unnecessary wakeup events and consequent ATS102 delays.  
 The application may return to low power mode after the serial interface has been inactive for the duration set by ATS100. This duration is measured from the last data sent or received on the serial interface.

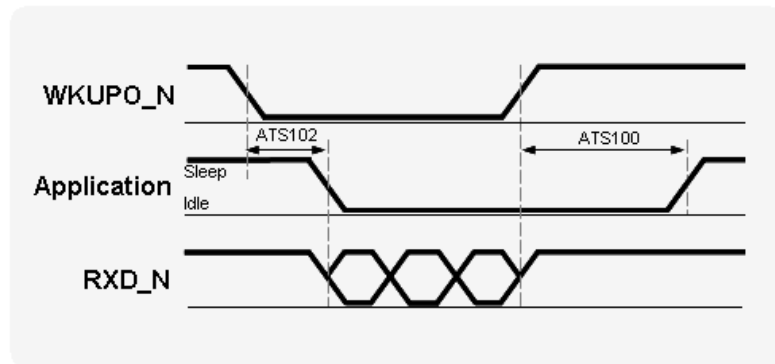

**Figure 2-28: WKUPO\_N Operation**

The following guidelines apply to the wakeup-out mechanism:

- G24 will set the WKUPO\_N signal low to indicate that it has data to send through the serial interface.
- G24 will start sending the data to the application after the delay defined by ATS102.
- The WKUPO\_N signal will remain low while data is being sent to the host application.
- The host application should keep its serial interface active, and not switch to low power mode, while the WKUPO\_N signal is low.
- G24 will set the WKUPO\_N signal high when it has completed sending the data.
- The application serial interface must stay active, and not switch to low power mode, for the duration set by ATS100, after WKUPO\_N is set high.
- G24 will not set the WKUPO\_N signal low if it needs to send additional data during the ATS100 delay time.
- The application may switch to low power mode after the WKUPO\_N signal is set high and the serial interface has been inactive for the duration set by ATS100.

## Antenna Detection

The G24 incorporates an internal antenna detection circuit, which senses the physical connection and removal of an antenna or antenna circuit on the G24 antenna connector. The antenna detection state is reported to the application through the ANT\_DET output signal, and may also be queried by the ATS97 command.

The detection circuit senses DC resistance to ground on the G24 antenna connector.

A DC resistance below 100kohm ( $\pm 10\%$ ) is defined as a valid antenna connection, and the ANT\_DET output signal is set high.

## GPRS/EGPRS Detection

The GPRS output signal indicates the network GPRS/EGPRS connection status. When G24 is connected to a GPRS/EGPRS network, this signal is enabled. When G24 is not connected to the GPRS/EGPRS network this signal is disabled.

## Transmission Indicator

The TXEN\_N output signal indicates when G24 is transmitting over the GSM network. This signal follows the G24 GSM transmit bursts. This signal is set low during transmission burst, and set high when no transmission is in progress.

Figure 2-29 shows the TXEN\_N operation.

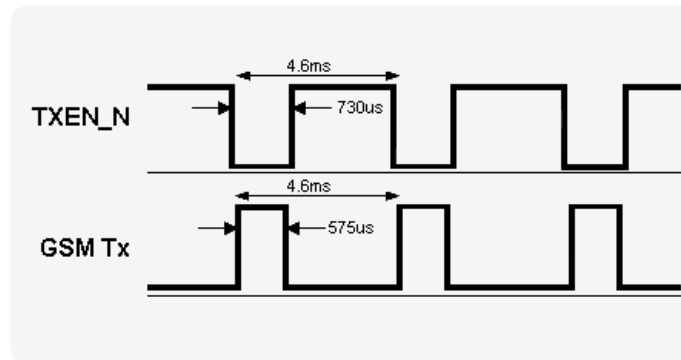

Figure 2-29: TXEN\_N Operation

## General Purpose I/O

The G24 incorporates 8 general purpose IO signals for the user application. Each GPIO signal may be configured and controlled by AT command. These signals may be used to control or set external application circuits, or to receive indications from the external application.

## Antenna Interface

The G24 antenna connector is the RF interface to the GSM network.

The antenna interface is terminated by an MMCX connector type, which is 50Ω impedance matched at the relevant GSM frequencies.

The antenna or antenna application must be installed properly to achieve best performance.

Table 2-24 gives the antenna interface specifications.

**Table 2-24: Antenna Interface Specifications**

Parameter	Conditions	Specifications
GSM 850	TX	824 - 849 MHz
	RX	869 - 893 MHz
GSM 900	TX	880 - 915 MHz
	RX	925 - 960 MHz
DCS 1800	TX	1710 - 1785 MHz
	RX	1805 - 1880 MHz
PCS 1900	TX	1850 - 1910 MHz
	RX	1930 - 1990 MHz
Gain		0 dBi (unity) gain or greater
Impedance		50Ω
VSWR		Less than: 2.5:1



## Chapter 3: Electrical and Environmental Specifications

### Absolute Maximum Ratings

Table 3-1 gives the maximum electrical characteristics of the G24 interface signals.

---

**Caution:** Exceeding the values may result in permanent damage to the module.

---

**Table 3-1: Maximum Ratings**

Parameter	Conditions	Min	Max	Unit
VCC Supply		-0.2	4.5	V
Digital Input Signals (Except for IGN, VBUS, USB_DP, USB_DN)	G24 powered on	-0.2	3	V
Analog Input Signals (Audio, A/D inter- faces)	G24 powered on	-0.2	2.75	V
All Input Signals (Except for IGN, VBUS, USB_DP, USB_DN)	G24 powered off	-0.2	0.2	V
IGN signal		-0.2	16	V
VBUS signal		-0.2	10	V
USB_DP, USB_DN		-0.2	5	V

## Environmental Specifications

Table 3-2 gives the environmental operating conditions of the G24 module.

**Caution:** Exceeding the values may result in permanent damage to the module.

**Table 3-2: Environmental Ratings**

Parameter	Conditions	Min	Max	Unit
Ambient Operating Temperature		-20	60	°C
Storage Temperature		-40	85	°C
ESD	At antenna connector Contact Air At interface connector		± 6 ± 15 ± 1	KV

## Application Interface Specifications

Table 3-3 summarizes the DC electrical specifications of the application interface connector signals.

**Important:** Interface signals that are not used by the customer application must be left unconnected. G24 incorporates the necessary internal circuitry to keep unconnected signal in their default state. Do not connect any components to, or apply any voltage on, signals that are not used by the application.

**Important:** It is recommended to place a pull-down resistor in the customer application, on the IGN signal. A 100 kohm resistor, or less, is acceptable.

**Important:** Signals that are defined as "Do Not Use", or DNU, must remain externally unconnected in any case. These signals are reserved for future use.

**Table 3-3: Interface Specifications**

Pin #	Signal Name	Description	I/O	Active H/L	Internal PU/PD	Parameter	Conditions	Level			
								Min	Typ	Max	Units
<b>Power:</b>											
1	GND	Ground									
2											
3											
4											
5	VCC	DC power supply	I			$V_{IN}$	VCC = 3.6 V	3.3	3.6	4.2	V
6						$I_{MAX}$		1.9	2.0	A	
7						$I_{OFF}$		75	85	$\mu$ A	
8											
<b>Control:</b>											
27	VREF	Reference regulator output	O			$V_{OUT}$ $I_{OUT}$	$I_{OUT} < 200$ mA Active mode Standby mode	-3%	2.75	+3%	V mA
16	WKUPI_N	G24 wakeup input	I	L	22K PU	$V_{IH}$ $V_{IL}$		2.0	2.775 0	3.0 0.4	V
26	WKUPO_N	Host wakeup output	O	L	22K PU	$V_{OH}$ $V_{OL}$	$I_{OUT} \leq 2$ mA	2.575	2.775 0	0.2	V
25	RESET_N	Reset signal output	O	L	47K PD	$V_{OH}$ $V_{OL}$	$I_{OUT} \leq 4$ mA	2.675	2.775 0	0.1	V
53	ON_N	On/Off switch	I	L	200K PU	$V_{IH}$ $V_{IL}$		2.0	2.775 0	3.0 0.2	V
51	IGN	Ignition input	I	H		$V_{IH}$ $V_{IL}$		2.0	0	16 0.4	V
39	TXEN_N	Transmit indicator	O	L		$V_{OH}$ $V_{OL}$	$I_{OUT} \leq 4$ mA	2.675	2.775 0	0.1	V
41	ANT_DET	Antenna presence indicator	O	L		$V_{OH}$ $V_{OL}$	$I_{OUT} \leq 2$ mA	2.575	2.775 0	0.2	V
49	GPRS	GPRS/EGPRS coverage indicator	O	L		$V_{OH}$ $V_{OL}$	$I_{OUT} \leq 2$ mA	2.575	2.775 0	0.2	V

Table 3-3: Interface Specifications (Cont.)

Pin #	Signal Name	Description	I/O	Active H/L	Internal PU/PD	Parameter	Conditions	Level				
								Min	Typ	Max	Units	
<b>UART1:</b>												
21	TXD_N	UART1 TXD	I	L	100K PU	$V_{IH}$ $V_{IL}$ $V_{OH}$ $V_{OL}$	$I_{OUT} \leq 2 \text{ mA}$	2.0	2.775	3.0	V	
11	RXD_N	UART1 RXD	O	L	100K PU							
9	RTS_N	UART1 RTS	I	L	100K PU							
15	CTS_N	UART1 CTS	O	L								
19	DTR_N	UART1 DTR	I	L	100K PU							
13	DSR_N	UART1 DSR	O	L	100K PU							
17	DCD_N	UART1 DCD	O	L	100K PU							
23	RI_N	UART1 RI	O	L	100K PU							
<b>UART2:</b>												
29	RXD2_N	UART2 RXD	O	L	100K PU	$V_{IH}$ $V_{IL}$ $V_{OH}$ $V_{OL}$	$I_{OUT} \leq 2 \text{ mA}$	2.0	2.775	3.0	V	
31	TXD2_N	UART2 TXD	I	L	100K PU							
33	RTS2_N	UART2 RTS	I	L	100K PU							
35	CTS2_N	UART2 CTS	O	L	100K PU							
<b>USB:</b>												
10	USB_VBUS	USB bus power	I	H		$V_{IH}$ $V_{IL}$	NOTE 1	4.5	5.0	5.25	V	
12	USB_DP	USB bus serial data	I/O	H								$V_{IH}$ $V_{IL}$
14	USB_DN	USB bus serial data	I/O	L		$V_{OH}$ $V_{OL}$		3.0	3.3	3.6	0.8	
								0	0	0.2		
								3.0	3.3	3.6	0.8	V
								0	0	0.3		

Table 3-3: Interface Specifications (Cont.)

Pin #	Signal Name	Description	I/O	Active H/L	Internal PU/PD	Parameter	Conditions	Level			
								Min	Typ	Max	Units
<b>SIM Card:</b>											
50	SIM_PD_N	SIM presence detect	I	L	47K PU	$V_{IH}$ $V_{IL}$	NOTE 2	2.0	2.775 0	3.0 0.4	V
48	SIM_VCC	SIM supply	O	H		$V_{OH}$		-3%	2.85	+3%	V
44	SIM_RST_N	SIM reset	O	L	5.6K PU	$V_{OH}$		2.85			V
52	SIM_DIO	SIM serial data	I/O	H	5.6K PU	$V_{OL}$		0	0.4		
46	SIM_CLK	SIM clock	O	H	5.6K PU						
<b>Digital Audio:</b>											
18	PCM_DIN	Digital audio receive	I	H	100K PD	$V_{IH}$	$I_{OUT} \leq 2 \text{ mA}$	2.0	2.775 0	3.0 0.4	V
20	PCM_DOUT	Digital audio transmit	O	H	100K PU	$V_{IL}$		2.575	2.775		
22	PCM_CLK	Digital audio clock	O	H	100K PD	$V_{OH}$		0	0.2		
24	PCM_FS	Digital audio frame sync.	O	H	100K PD	$V_{OL}$					

Table 3-3: Interface Specifications (Cont.)

Pin #	Signal Name	Description	I/O	Active H/L	Internal PU/PD	Parameter	Conditions	Level			
								Min	Typ	Max	Units
<b>GPIO:</b>											
28	GPIO1	General purpose I/O	I/O		100K PU	$V_{IH}$ $V_{IL}$ $V_{OH}$ $V_{OL}$	$I_{OUT} \leq 2 \text{ mA}$	2.0	2.775	3.0	V
30	GPIO2	General purpose I/O	I/O		100K PU						
32	GPIO3	General purpose I/O	I/O		22K PU						
34	GPIO4	General purpose I/O	I/O		22K PU						
36	GPIO5	General purpose I/O	I/O		22K PU						
38	GPIO6	General purpose I/O	I/O		22K PU						
40	GPIO7	General purpose I/O	I/O		22K PU						
42	GPIO8	General purpose I/O	I/O		22K PU						
<b>Audio:</b>											
67	SPKR_N	Speaker inverted	O			$R_L$	Single ended, no load		32	2.5	$\Omega$
69	SPKR_P	Speaker	O			$V_{ACPP}$					
63	ALRT_N	Alert speaker inverted	O			$R_L$	Single ended, no load		8	3.5	$\Omega$
65	ALRT_P	Alert speaker	O			$V_{ACPP}$					
61	MIC	Microphone input	I			$R_{IN}$			1K	2.5	$\Omega$
						$V_{ACPP}$					
59	AGND	Audio ground									
57	HDST_MIC	Headset microphone input	I			$R_{IN}$			1K	2.5	$\Omega$
						$V_{PP}$					
55	HDST_INT_N	Headset detect interrupt	I	L	200K PU	$V_{IH}$		2.0	2.775	3.0	V
						$V_{IL}$					

Table 3-3: Interface Specifications (Cont.)

Pin #	Signal Name	Description	I/O	Active H/L	Internal PU/PD	Parameter	Conditions	Level			
								Min	Typ	Max	Units
<b>A/D:</b>											
37	ADC1	General purpose A/D	I			$V_{IN}$		0		2.75	V
43	ADC2	General purpose A/D	I			$V_{IN-ACTIVE}$		0		2.3	V
47	ADC3	General purpose A/D	I			$I_{ADC}$			0.75	1	mA
45	UID	Do Not Use				Resolution			10		mV
<b>Display:</b>											
54	CLI_CS	Do Not Use									
60	LCD_RS	Do Not Use									
56	LCD_DATA	Do Not Use									
58	LCD_CLK	Do Not Use									
<b>Data Logger:</b>											
70	SPI_CS	Do Not Use									
62	SPI_IRQ_N	Do Not Use									
64	SPI_DIN	Do Not Use									
68	SPI_DOUT	Do Not Use									
66	SPI_CLK	Do Not Use									

**Note 1:**Per USB Specifications Rev 2.0.

**Note 2:**Per ISO 7816-3 IC specifications.



# Chapter 4: Mechanical Specifications

## Board Dimensions

Figure 4-1 describes the G24 mechanical characteristics.

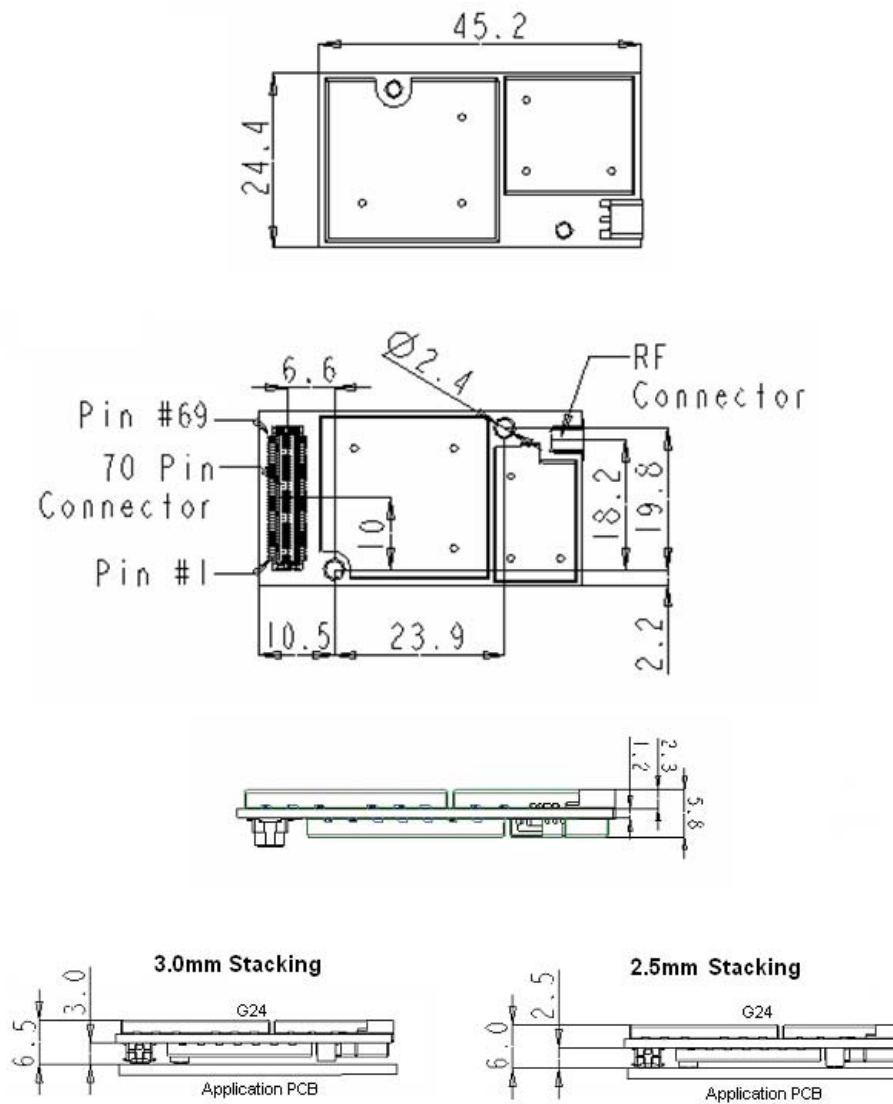

Figure 4-1: G24 Mechanical Characteristics

## Interface Connector Specifications

The G24 uses a single 70-pin, 0.5 mm pitch, board to board connector for the application interface, which is available in 2 stacking height versions, as described in [Table 4-1](#).

**Table 4-1: G24 interface connector options**

G24 Connector	Mating Connector	Stacking Height
Molex 53748-0708	Molex 52991-0708	3.0 mm
Molex 53885-0708	Molex 54102-0708	2.5 mm

[Figure 4-2](#) shows the G24 interface connectors.

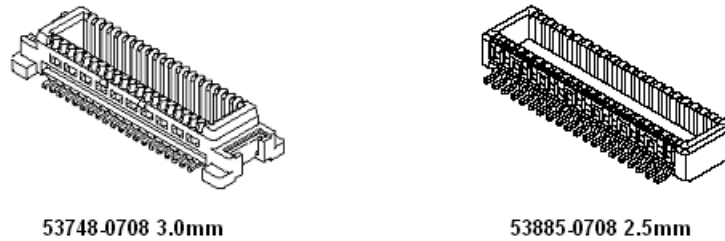

**Figure 4-2: G24 Interface Connectors**

[Table 4-2](#) describes the G24 interface connectors characteristics.

**Table 4-2: Interface Connector Specifications**

Parameter	53748 (3.0 mm)	53885 (2.5 mm)
Contacts	70	70
Rows	2	2
Pitch	0.5 mm	0.5 mm
Maximum Current	500 mA	500 mA
Maximum Voltage	50 V	50V
Contact Resistance	50 mΩ maximum	40 mΩ maximum
Insulation Resistance	100 MΩ minimum	100 MΩ minimum
Durability	50 mated cycles maximum	30 mated cycles maximum
Stacking Height	3.0 mm	2.5 mm
Mates with	Molex 52991-0708	Molex 54102-0708

## Mating Connectors

The mating connectors incorporate the same electrical and mechanical characteristics as the corresponding G24 interface connectors, which are described in [Table 4-2](#).

[Figure 4-3](#) provides a reference drawing of the mating connectors mechanical dimensions.

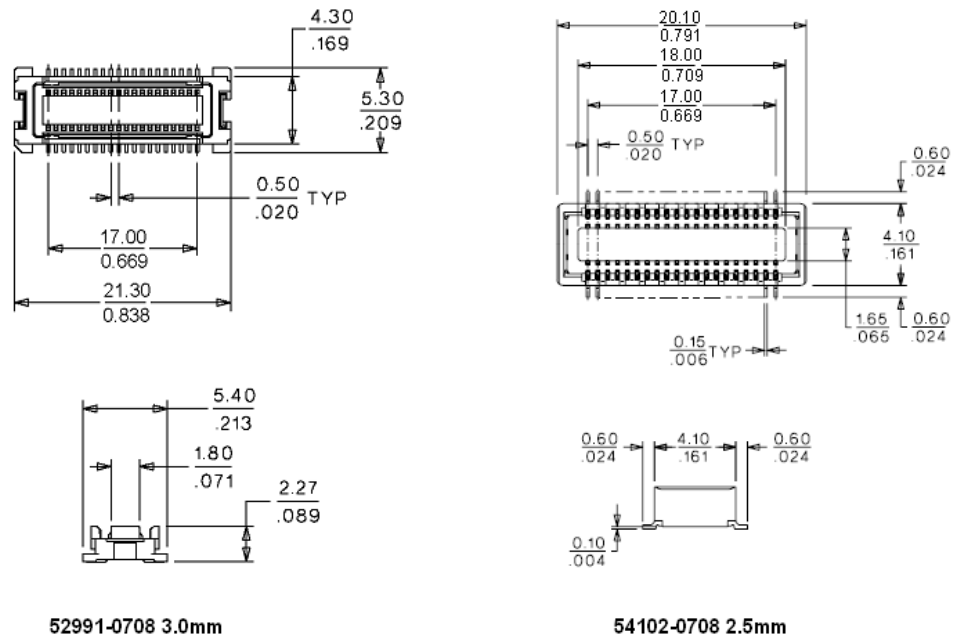

**Figure 4-3: Mating Connectors Dimensions**

For more information on the G24 mating connectors, please refer to the Molex web site at <http://www.molex.com>.

## RF Connector Specifications

The G24 uses a standard MMCX receptacle connector for the radio interface. The connector is manufactured by Amphenol, PN MMCX6251S5.

Figure 4-4 shows the MMCX connector dimensions.

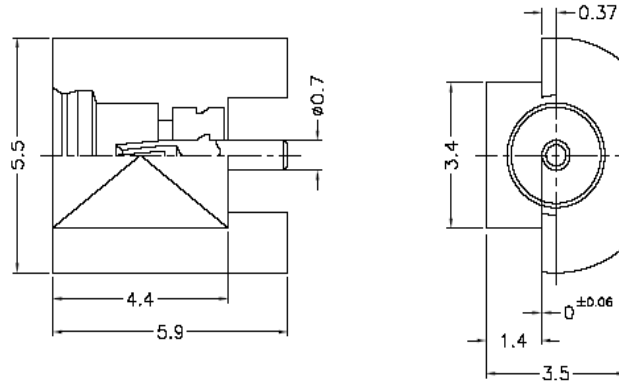

**Figure 4-4: MMCX Connector Dimensions**

Table 4-3 describes the G24 RF connector characteristics.

**Table 4-3: RF Connector Specifications**

Parameter	Specifications
Rated Voltage	335 V <sub>RMS</sub>
Impedance	50 Ω
Contact Resistance	5 mΩ center contact 2.5 mΩ outer contact
Insulation Resistance	1000 MΩ
Insertion Force	3.4 lbs maximum
Withdrawal Force	4.5 lbs maximum
Contact Retention Force	4 lbs maximum
Durability	500 mated cycles maximum

## Mating Connector

The RF mating connector should be a standard MMCX plug connector or cable assembly, which corresponds to the G24 MMCX connector specifications.

Any standard MMCX connector or application from different manufacturers may be mated with G24.

Such a cable assembly example is the Huber-Suhner PN 11\_MMCX-50-1-2/111\_OH, which is illustrated in Figure 4-5.

<b>Item description</b> 11_MMCX-50-1-1/111_OH		
Connector Description	Straight cable plug for flexible cable	
Series / Pattern Highlights	<ul style="list-style-type: none"> <li>• MMCX – Type / <a href="#">Pattern 11</a></li> <li>• SUHNER full crimp cable attachment</li> </ul>	
Item number	22651666	
Data sheet	<a href="#">11_MMCX-50-1-1/111_O</a>	
Outline drawing	<a href="#">11_MMCX-50-1-1/111_O</a>	
Catalogue drawing	<a href="#">11_MMCX-50-1-1/111_O</a>	
Related documents	<a href="#">Assembly Instruction</a>	
2002/95/EC (RoHS)	<input checked="" type="checkbox"/> compliant	
Interface Standards	SUHNER-MMCX	
<b>Mechanical data</b>		Jump to <a href="#">[Top]</a>
Cable Entry Centre Contact		crimped
Cable Entry Outer Contact		crimped
Engagement Force max		15 N
Disengagement F. min		6 N
Disengagement F. max		15 N
Dielectric Size		1
<b>Electrical data</b>		Jump to <a href="#">[Top]</a>
Impedance		50 $\Omega$
Interface Freq max		$\leq$ 6 GHz
<b>Environmental and general data</b>		Jump to <a href="#">[Top]</a>
Operating Temp min		-55 °C
Operating Temp max		155 °C
Weight		0.0009 kg
Number of Matings		500

Figure 4-5: Optional MMCX Cable Assembly

## G24 Mounting

The G24 incorporates 2 mechanical holes for installing the module onto the application board. The holes are 2.4 millimeters in diameter, which accommodates several types of mechanical elements.

Several mechanical approaches may be applied to mount and fasten G24 to the application board. Using M2 screws with suitable washers to mount the module onto spacers, a bracket or chassis is a recommended design.

Special attention must be paid to the area surrounding the G24 mounting holes. Several electrical components, which are not shielded, are located near the holes. These components must not be in contact with the mounting elements or with other parts of the application board, and care must be taken to avoid any damage.

The holes are used for mechanical mounting of G24 to the application board but also for grounding support. Using conductive elements to install G24 significantly improves the overall grounding of the module and therefore improves the G24 performance and stability.

It is required to use screws or other mechanical elements to fasten G24 to the application board, but it is highly recommended to use conductive elements to improve the module's performance.

## Chapter 5: Service and Testing

---

### Service

This section provides contact information for any possible queries that may arise, for example:

- Have questions?
- Having trouble getting the Developer Board set up?
- Technical questions?
- Configuration questions/problems?
- Technical operating problems?
- Need documentation?

### Who to Contact?

The **GSM/CDMA Data Module Customer Support Center** is ready to assist you on integration issues.

**Direct Customer.** Use this following email address to contact customer assistance:  
**M2M.CustomerCare@motorola.com**

**Note:** The support services provided by Motorola are subject to the agreement between the customer and Motorola and may be at an additional charge to the customer. Motorola will inform the customer in advance of any such charge.

**Indirect Customer.** Send requests to your distributor and not to Motorola help desk.

### Required Query Information

Every new call/problem report, directly from a Direct Customer or from a distributor, should be directed to the help desk email address noted above in “[Who to Contact?](#)”. It is recommended to report each individual issue in a separate email. The following information is required when reporting a problem:

- Customer name and address
- Customer contact information for this request, including:
  - Name
  - Telephone
  - Fax number
  - Mobile number
  - Email address
- Product name (G24)

- Software version of the unit (ATI8 command) or model number
- PCB version (located on the PCB near the RF connector)
- Severity of the problem
- Problem description, including:
  - Operator name
  - Type of SIM card (for example, Test, Pre-paid, or 5v/3v/1.8v)
  - Setup Configuration (such as Developer Board, handset, host, connections, and so on)
  - Detailed scenario from startup
  - Log of all the commands and the responses, beginning from startup
- Answers to the following questions:
  - Was the same scenario tested on the Developer Board and the PC to reproduce the problem?
  - How many units do you have, and how many of them have this problem?
  - How often does the problem recur?

In addition to the information requested above, send the following AT commands and the HyperTerminal log with the responses:

- **AT+CMEE=2** // to get textual error message
- **AT+CPIN?** // to get SIM card status
- **AT+CREG?** // to see if the TXVR is registered to the network
- **AT+CSQ** // to get the signal strength (RX level)
- **AT+CGSN** // to read the IMEI number of the unit
- **ATI3** // to get the software version of the TXVR
- **AT+S** // to get the setting of basic AT commands
- **AT+CMER=0,0,1,1** // to get messages and indicators from the handset display to the DTE

## Motorola Workflow

The help desk uses the following workflow when responding to new calls:

1. Each new call is registered in the help desk data base.
2. The help desk immediately notifies the customer with the help desk system record number for each issue.
3. A champion is assigned to be responsible for the new call, from arrival to closing.
4. During this time, the champion updates the help desk system with the progress of the resolution process.
5. The champion is the contact to the customer and the engineering team, and coordinates activities that are required to solve the problem.

## Service Centers

### **Motorola Electronics Taiwan PCS**

11F, No, 296, Sec. 4, Jen-Ai Road  
Taipei, 106, Taiwan, R.O.C

### **Motorola GmbH**

Am Sophienhof 10  
D-24941 Flensburg  
Germany

### **Motorola Communications ISRAEL Ltd.**

Service Operation  
Attention: Shukrun Ofer  
3 Kremetski Street  
Tel Aviv, Israel 67899  
Telephone: (972) 3 5658829

### **JNB Electronics Pty Ltd.**

347 Settlement Road, Thomastown  
VIC 3074  
Australia

### **Flextronics**

Transportation group leader  
Zalaegerszeg Industrial Park 1 PCC  
Building 1 PCC Posta u. 63  
H-8900 Zalaegerszeg  
Hungary

### **BGH do Brasil Comunicações e Serviços Ltda.**

Al Ceci, 534 - Galpão 3  
Barueri - SP - Brazil  
Tel: 54 11 4309 2046

### **FeiHongDaLi Telecommunications Technology Co.Ltd.,TianjinSHI**

B-6F JuFu Yuan Building  
XinKai Road, Hedong District,  
Tianjin 300011  
China

Field service should be coordinated with the Service Manager in Motorola using the following email address: **n2csfs01@motorola.com**

## Testing a Standalone Unit

This section describes how to perform a G24 functionality test, whose purpose is to:

- Introduce the user to the G24
- Explain how to work with the G24 unit
- Describe how to evaluate basic G24 features

The test setup provides a wide platform through which a G24 unit can be evaluated. The specific test procedure described below covers only a few of the G24's many features. Using this setup, you can perform several additional tests on the G24.

The test is performed using two modems, one of which is the G24. The modems communicate with each other through a single computer, which also controls their operation.

The test requires knowledge about the operation of the G24 Developer's Kit, terminal applications and AT commands. Refer to relevant documentation for assistance.

To perform the test, you need the following:

- A G24 OEM cellular engine unit
- A G24 Developer's Kit
- A desktop or laptop computer, which includes:
  - A free serial communications port (RS232)
  - A connected and active line modem (internal or external)
  - A terminal application (such as HyperTerminal)

## Test Setup

### To Setup the G24 Test

Follow this procedure ([Figure 5-1](#)) to set up your equipment before performing the test:

1. Verify that the computer you intend to use for the test is equipped with a working line modem

*You can use a second G24 unit instead of the line modem. When doing so, you must repeat the setup procedure that follows for the additional G24.*

2. Set up the G24 and the Developer Board as described in “[Initial Setup](#)” in “[Chapter 2: Developer Board and Interfaces Description](#)” in the “[G24 Developer's Kit](#)” (Motorola part no. 6889192V26)
3. Verify that the G24 has adequate reception from the local GSM network
4. Connect the Developer Board's RS232 port to the computer's serial port
5. Open a terminal application window (such as HyperTerminal) and configure it to operate with the serial port occupied by the **G24**

- Open a second terminal window and configure it to operate with the serial port occupied by the **line modem**

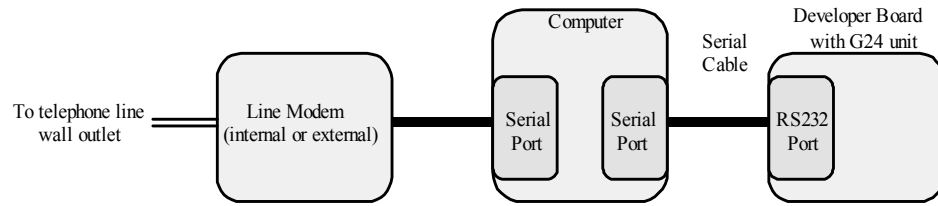

**Figure 5-1: Test Setup**

## Test Procedure

### To Perform the G24 Test

Follow the procedure below to perform the G24 test:

1. Verify that the G24 is functioning and communicating with the computer by performing the following AT commands in the G24 terminal window:

- **ati7**—prompts G24 identification

*The G24 will reply G24 OEM Module.*

- **ati8**—prompts the G24 software version

2. Verify that the line modem is functioning and communicating with the computer by entering the AT command **at** in the modem's terminal window

*This common AT command prompts a properly working modem to reply OK.*

3. Make a CSD data call from the G24 to the line modem or the reverse using the **atdt** and **ata** commands in the appropriate window

4. Verify that a connection between the two modems is established

5. Select any file to transfer between the two modems

*The file can be any existing file, or a new file created specifically for the test.*

6. Send the file either from the G24, or to the G24, through the terminal application using the terminal application's send/receive file options

7. When the file transfer is complete, use the **ath** command in any of the terminal windows to terminate the call

*This step completes the test. You can now continue to perform additional tests using the same setup, or change the setup as required.*

# Acronyms and Abbreviations

---

Abbreviation	Full Name
<b>A</b>	
<b>AMR</b>	Adaptive Multi Rate
<b>AOC</b>	Advice of Charge
<b>B</b>	
<b>BR</b>	Baud Rate
<b>bps</b>	Bits Per Second
<b>C</b>	
<b>CSD</b>	Circuit Switched Data
<b>CTS</b>	Clear to Send
<b>D</b>	
<b>DCD</b>	Data Carrier Detect
<b>DCE</b>	Data Communication Equipment (such as modems)
<b>DCS</b>	Digital Cellular System (GSM in the 1800MHz band)
<b>DOC</b>	Department of Communications (Canada)
<b>DRX</b>	Discontinuous Reception
<b>DSP</b>	Digital Signal Processor
<b>DSR</b>	Data Set Ready
<b>DTE</b>	Data Terminal Equipment (such as terminals, PCs and so on)
<b>DTMF</b>	Dual Tone MultiFrequency
<b>DTR</b>	Data Terminal Ready
<b>DTX</b>	Discontinuous Transmission
<b>E</b>	
<b>EFR</b>	Enhanced Full Rate
<b>EGPRS</b>	Enhanced General Packet Radio Service
<b>EGSM</b>	Extended Global System for Mobile Communications
<b>EIRP</b>	Effective Isotropic Radiated Power
<b>EMC</b>	Electromagnetic Compatibility
<b>EOTD</b>	Enhanced Observed Time Difference
<b>EPOS</b>	Electronic Point of Sale
<b>ERP</b>	Effective Radiated Power
<b>ESD</b>	Electrostatic Discharge
<b>ETSI</b>	European Telecommunication Standards Institute

Abbreviation	Full Name
<b>F</b>	
<b>FCC</b>	Federal Communications Commission (U.S.)
<b>FR</b>	Full Rate
<b>FTA</b>	Full Type Approval
<b>G</b>	
<b>GCF</b>	GSM Certification Forum
<b>GPIO</b>	General Purpose Input/Output
<b>GPRS</b>	General Packet Radio Service
<b>GSM</b>	Global System for Mobile Communications
<b>H</b>	
<b>HR</b>	Half Rate
<b>I</b>	
<b>IC</b>	Integrated Circuit
<b>L</b>	
<b>LNA</b>	Low-noise Amplifier
<b>M</b>	
<b>MMCX</b>	Miniature Micro Coax
<b>MO</b>	Mobile Originated
<b>MT</b>	Mobile Terminated
<b>O</b>	
<b>OEM</b>	Original Equipment Manufacturer
<b>P</b>	
<b>PCB</b>	Printed Circuit Board
<b>PCL</b>	Power Class Level
<b>PCM</b>	Pulse Code Modulation
<b>PCS</b>	Personal Communication System (also known as GSM 1900)
<b>PD</b>	Pull Down
<b>PDA</b>	Personal Data Assistant
<b>PDU</b>	Packet Data Unit
<b>PLL</b>	Phase-locked Loop
<b>PTCRB</b>	PCS-1900 Type Certification Review Board (GSM North America)
<b>PU</b>	Pull Up

Abbreviation	Full Name
<b>R</b>	
<b>R&amp;TTE</b>	Radio and Telecommunications Terminal Equipment
<b>RMS</b>	Root Mean Square
<b>RI</b>	Ring Indicator
<b>RTS</b>	Request To Send
<b>S</b>	
<b>SAR</b>	Specific Absorption Rate
<b>SIM</b>	Subscriber Identity Module
<b>SMS</b>	Short Message Service
<b>SPI</b>	Serial Peripheral Interface
<b>T</b>	
<b>TDMA</b>	Time Division Multiple Access

---

Abbreviation	Full Name
<b>U</b>	
<b>UART</b>	Universal Asynchronous Receiver Transmitter
<b>USB</b>	Universal Serial Bus
<b>USSD</b>	Unstructured Supplementary Services Data
<b>V</b>	
<b>VCC</b>	Voltage Common Collector
<b>VSWR</b>	Voltage Standing Wave Ratio

# Index

---

## A

Antenna Installation, [xi](#)  
Approvals  
Regulatory, [5](#)

## B

Block Diagram Description, [7](#)

## E

Environmental  
Specifications, [3](#)

## G

G24  
Abbreviations, [2](#)  
Antenna Installation, [xi](#)  
Block Diagram Description, [7](#)  
Product Specifications, [2](#)  
Regulatory Approvals, [5](#)  
Safety Precautions, [x](#)  
Standards, [xi](#)  
Terms and Abbreviations, [2](#)  
Testing, [70](#)  
User Operation, [x](#)

## O

Organization of Manual, [xix](#)

## P

Physical Specifications, [2](#)  
Precautions, [x](#)  
Product Specifications, [3](#)

## R

Regulatory Approvals, [5](#)

## S

Safety Precautions, [x](#)  
Specifications, [2](#)  
Environmental, [3](#)  
Physical, [2](#)  
Standards, [xi](#)  
Support Center, [67](#)

## T

Terms, [2](#)  
Testing, [70](#)  
Test Procedure, [72](#)  
Test Setup, [70](#)

## U

User Operation, [x](#)







MOTOROLA and the Stylized M Logo are registered in the US Patent & Trademark Office.

All other product or service names are the property of their respective owners.

©Copyright 2005 Motorola, Inc.

Java™ Technology and/or J2ME™ : Java and all other Java-based marks are trademarks or registered trademarks of Sun Microsystems, Inc. in the U.S. and other countries.

UNIX® : UNIX is a registered trademark of The Open Group in the United States and other countries.



**6889192V27-D**