



G24-L
Product Specifications

DRAFT

G24-L GSM/GPRS Module

Jul 04, 2007

Version 0.07

Table of Contents

1	PURPOSE AND SCOPE	3
2	GENERAL SPECIFICATIONS	4
2.1	PRODUCT SPECIFICATIONS LIST.....	4
2.2	PRODUCT MODELS	5
2.3	SAFETY AND REGULATIONS APPROVALS	5
3	MECHANICAL SPECIFICATIONS	6
3.1	BOARD DIMENSIONS	6
3.2	INTERFACE CONNECTOR SPECIFICATIONS.....	7
3.3	RF CONNECTOR SPECIFICATIONS	7
4	ELECTRICAL SPECIFICATIONS	8
4.1	OPERATING MODES	8
4.2	POWER SUPPLY	9
4.2.1	POWER CONSUMPTION.....	9
4.3	POWER ON/OFF OPERATION	10
4.4	LOW POWER MODE	10
4.5	REAL TIME CLOCK	10
4.6	SERIAL INTERFACES	11
4.6.1	UART	11
4.6.2	USB INTERFACE.....	12
4.7	SIM INTERFACE	12
4.8	AUDIO INTERFACE	13
4.9	A/D INTERFACE.....	13
4.10	CONTROL AND INDICATORS INTERFACE	13
4.10.1	RESET	13
4.10.2	WAKE-UP OUT	13
4.10.3	ANTENNA DETECTION.....	14
4.10.4	GPRS DETECTION.....	14
4.10.5	TRANSMISSION INDICATOR	14
4.11	GENERAL PURPOSE I/O	14
4.12	ANTENNA INTERFACE.....	14
4.13	CHARGER MODEL.....	14
4.14	INTERFACE CONNECTOR PINOUT.....	16
5	FEATURES SPECIFICATIONS	18
5.1	AT COMMANDS	18
5.2	FEATURE LIST	34



1 Purpose and Scope

The purpose of the Product Specification is to provide a description of the G24-L product. This product reference includes technical specifications of the product and can be used as reference.

2 General Specifications

2.1 Product Specifications List

Feature	Description
Technologies	GSM, GPRS
Size (mm) (L x W x H)	45.2 x 24.4 x 6 (mm)
Weight (g)	About 10 Gram
GSM Bands	Quad Band: 900/1800 - 850/1900 Mhz
Release Compliant	R97/R98
GPRS Data Transfer	Multi Slot Class 10 (4 Down, 2 Up)
Voice	Vocoders: AMR / EFR/ FR/ HR
Packet	CS: CS1-CS4
CSD - data call	BR 14.4 Kbps
PDP types	IP Internet Protocol (IETF STD 5)
RF Connector	MMCX
Interface Connector	70 Pin Connector
External SIM	External - 1.8V/3V
GPRS	AT Commands List
TCP/IP (Ascii & Binary Modes)	AT Commands List
Antenna Detect	AT Commands List
USB Port - full speed	USB 1.1
RS232	1 Full handshake
SMS (PDU and Text)	Yes
STK (SIM Tool Kit)	No
Analog Audio	Yes
Fax	Yes
Digital Audio	Linear PCM Bus
GPIO	8 (PU/PD TBD)
ADC	3 General Purpose
ETSI mandatory	3GPP TS 27.005 V6/V7 3GPP TS 27.007 V6/V8
Firmware Upgrades	Yes
Configuration Upgrades	Yes
Logging/Debug	Yes
Mux 27.010	No

2.2 Product Models

The G24-L product will be released in 2 different models as following:

- G24-L Standard
- G24-L Standard + Charger

The G24-L Standard Model will include the standard functionality described in this Product Spec. The G24-L Standard + Charger Model will include the standard model plus the charger circuit and functionality.

2.3 Safety and Regulations Approvals

The G24-L module is compliant with the following Standards:

- FCC
- PTCRB
- R&TTE
- GCF
- EMC
- IC
- Environment: RoHS, WEEE, Mercury Legislation, Proposition 65 regulations and People's Republic of China MII RoHS/WEEE

3 Mechanical Specifications

The following sections describe in detail the Mechanical Specifications of the G24-L Module.

3.1 Board Dimensions

The following image describes the module mechanical characteristics.

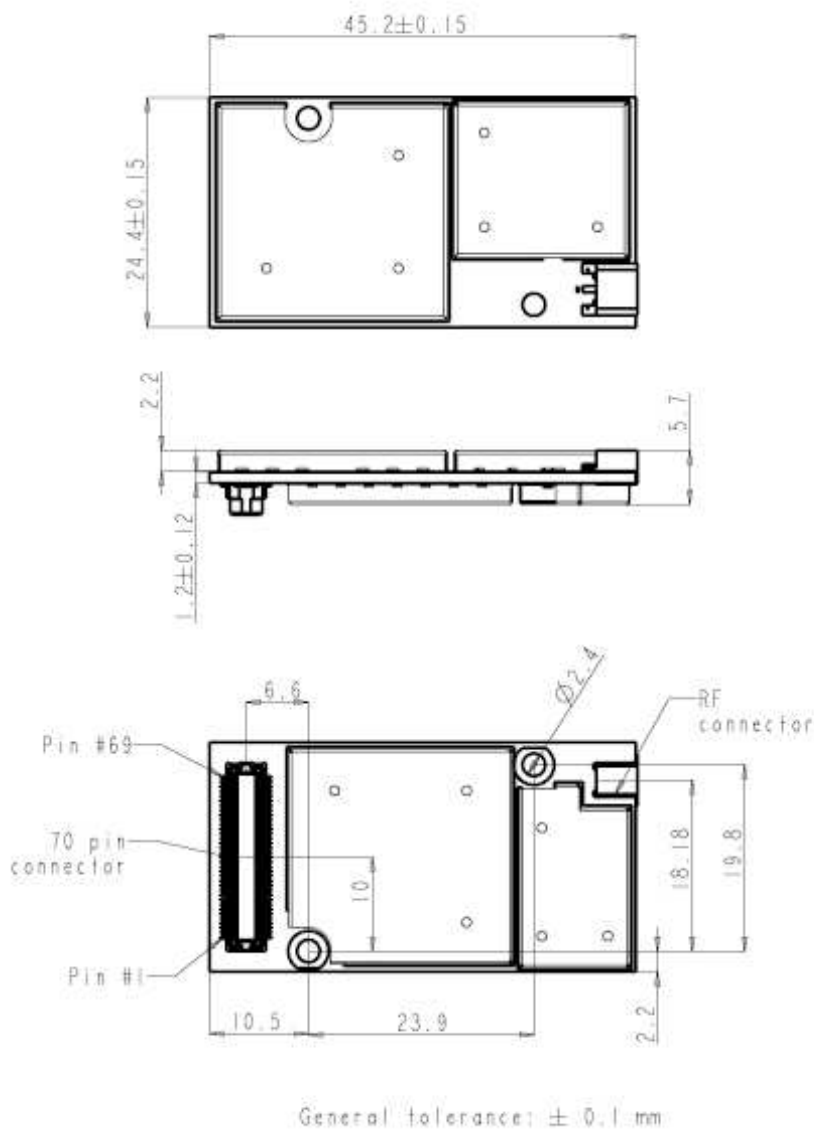

3.2 Interface Connector Specifications

The module uses a single 70-pin, 0.5 mm pitch, board to board connector for the application interface, as described in the following table.

G24-L interface connector options

Module Connector	Mating Connector	Stacking Height
Molex 53748-0708	Molex 52991-0708	3.0 mm

3.3 RF Connector Specifications

The module uses an MMCX receptacle connector for the radio interface. One of the vendors of the connector is Amphenol, PN MMCX6251S5.

4 Electrical Specifications

4.1 Operating Modes

The module incorporates several operating modes. Each operating mode is different in the active features and interfaces.

The following table summarizes the general characteristics of the module operating modes and provides general guidelines for operation.

Module Operating Modes

Mode	Description	Features
Not Powered	VCC supply is disconnected	Module is Off. The interface signals are tri-stated.
RTC Mode	Valid VCC supply, RESET_N signal is enabled (low).	The Module interface is tri-stated. Only the internal RTC timer is active.
Idle Mode	RESET_N signal is disabled (high), CTS_N and DSR_N signals are enabled (low).	The module is fully active and ready to communicate. This is the default power-up mode.
Low power Mode	RESET_N signal is high, CTS_N signal is disabled	The module is in low power mode. The application interfaces are disabled, but it continues to monitor the GSM network.
CSD call or GPRS data	RESET_N signal is high, TXEN_N signal is toggling.	A GSM voice or data call is in progress. When the call terminates, The Module will return to the last operating state (Idle or Sleep).

4.2 Power Supply

The Module power supply must be a single external DC voltage source of 3.3V to 4.5V.

Power supply signals

Pin (s)	Signal Name	Description
1-4	GND	Main ground connection for the module.
5-8	VCC	DC supply input for the module. $V_{IN} = 3.3 \text{ V to } 4.2 \text{ V}$ $I_{MAX} \leq 2 \text{ A during transmit bursts}$

4.2.1 Power Consumption

The following table specifies typical current consumption ratings of the module in various operating modes. The current ratings refer to the overall current consumption through the VCC supply.

Current ratings (VCC ≥ 3.3V)

Parameter	Description	Conditions	Min	Typ	Max	Unit
I_{OFF}	RTC mode				45	uA
I_{IDLE}	Idle mode	Registered			30	mA
I_{SLEEP}	Low power mode	DRX $\frac{2}{9}$			$\frac{5}{3}$	mA
$I_{GSM-RMS}$	Average current GSM voice – 1 TX slot 1 RX slot	DTX Off			260	mA
$I_{GPRS-RMS}$	Average current GPRS Class10 – 2 TX slots 3 RX slots	DTX Off			520	mA
$I_{GSM-MAX}$	Maximum TX current burst				2000	mA

4.3 Power On/Off Operation

The Module power on and off process includes 2 primary phases, which are indicated at the interface connector by the hardware output signals RESET_N and CTS_N.

The RESET_N signal indicates whether the module is powered on or off. When this signal is enabled (low), the module is powered-off. When it is disabled (high), the module is powered-on.

The CTS_N signal indicates the serial communications interface (UART) status. When this signal is high, the module serial interface is tri-stated. When it is low, the serial interface is enabled, and the module is ready to communicate.

4.4 Low Power Mode

The module incorporates an optional low power mode, sleep mode, in which it operates in minimum functionality, and therefore draws significantly less current. In low power mode the module network connection is not lost. It continues to monitor the GSM network constantly for any incoming calls or data.

During low power mode, all the module interface signals are inactive and are kept in their previous state, prior to activating low power mode. To save power, the module's internal clocks and circuits are shut down, and therefore serial communications is limited.

The module will not enter low power mode in any case when there is data present on the serial interface or incoming from the GSM network or an internal system task is running. Only when processing of any external or internal system task has completed, the module will enter low power mode according to the ATS24 command settings.

4.5 Real Time Clock

The module incorporates a Real Time Clock (RTC) mechanism that performs many internal functions, one of which is keeping time. The RTC subsystem is embedded in the module and operates in all the different operating modes (Off, Idle, Sleep), as long as power is supplied above the minimum operating level.

The module time and date can be set by the following methods:

- Automatically retrieved from the GSM network.
In case the module is operated in a GSM network that supports automatic time zone updating, it will update the RTC with the local time and date upon connection to the network. The RTC will continue to keep the time from that point.
- Using the AT+CCLK command.
Setting the time and date manually by this AT commands overrides the automatic network update. Once the time and date are manually updated, the RTC timer will keep the time and date synchronized regardless of the module operating state.

When the power supply is disconnected from the module, the RTC timer will reset and the current time and date will be lost. On the next module power-up the time and date will need to be set again automatically or manually

4.6 Serial Interfaces

The module includes 2 completely independent serial communications interfaces, which may be used by the application for several purposes.

4.6.1 UART

The module's primary UART is a standard 8-signal bus. The primary UART is used for all the communications with the module – AT commands interface, GPRS data and CSD data, programming and software upgrades.

The UART signals are active low CMOS level signals. For standard RS232 communications with a PC, an external transceiver is required.

The module is defined as a DCE device, and the user application is defined as the DTE device. These definitions apply for the UART signals naming conventions, and the direction of data flow, as described in the following figure.

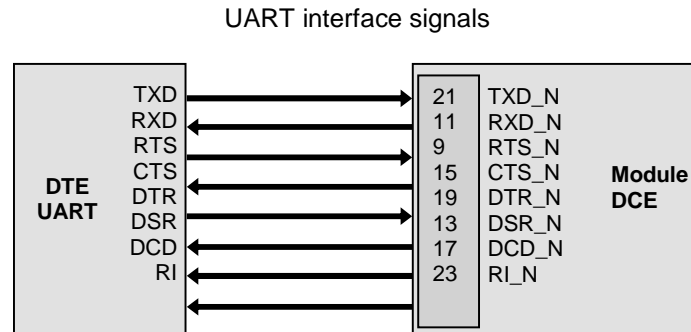

The primary UART supports the baud rates 300, 600, 1200, 2400, 4800, 9600, 19200, 230400, 38400, 460800, 57600 and 115200 bps.

Auto baud rate detection is supported for baud rates up to 460 kbps.

All flow control handshakes are supported: hardware, software, or none.

Parity bit and Stop bit definitions are also supported.

The UART default port configuration is 8 data bits, 1 stop bit and no parity, with hardware flow control and auto baud rate detect enabled.

4.6.2 USB Interface

The module incorporates a standard Universal Serial Bus (USB) interface. The USB electrical interface and protocol conform to the USB 1.1 full-speed specifications. The module is defined as a USB device on the USB bus and does not support hub or host functionality.

USB may be used for standard communications with the module, as done through the UART interface. When USB is active, the module's low power mode cannot be operated.

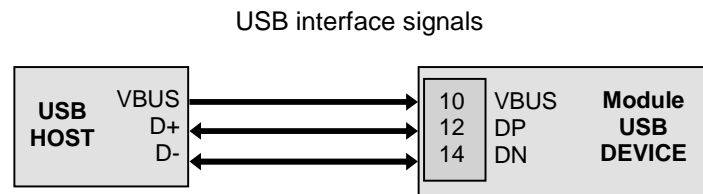

4.7 SIM Interface

The module incorporates a SIM interface, which conforms to the GSM 11.11 and GSM 11.12 standards, which are based on the ISO/IEC 7816 standard. These standards define the electrical, signaling and protocol specifications of a GSM SIM card.

The module does not incorporate an on-board SIM card tray for SIM placement. The SIM must be located on the user application board, external to the module. The module SIM interface includes all the necessary signals, which are routed to the interface connector, for a direct and complete connection to an external SIM.

The module supports dynamic detection of the SIM card, through a dedicated SIM detection signal. The module detects a SIM card insertion or removal upon power up or during operation by the transitions on the SIM_PD_N signal. SIM voltage 1.8V/3V

4.8 Audio Interface

The module supports the following audio devices:

- Handset Microphone Port
- Headset Microphone Port
- Speaker Port
- Headset Detection
- Alert Loudspeaker Port
- Digital Audio Interface

4.9 A/D Interface

The module includes 3 Analog to Digital Converter (ADC) signals with 10-bit resolution, for environmental and electrical measurements.

The A/D signals operation and reporting mechanism is defined by the AT+MMAD command.

Note: In the Charger Model 1 A/D port is assigned to the battery temperature measurement.

4.10 Control and Indicators Interface

The module incorporates several interface signals for controlling and monitoring its operation. The following section describes these signals and their operation.

4.10.1 Reset

The RESET_N output signal indicates the module's operating status. This signal is set high after power up, when the module is operating. It is set low when the module is powered off.

When the RESET_N signal is low, the module's application interface signals are disabled and do not represent any valid data or state.

4.10.2 Wake-Up Out

The wakeup-out (WKUPO_N) signal is an active low output, which is designed to support a low power mode feature in the host application. This signal is used by the module to indicate that it requires to communicate with the host application through the serial interface, due to an incoming call or data, or an unsolicited event.

4.10.3 Antenna Detection

The module incorporates an internal antenna detection circuit, which senses the physical connection and removal of an antenna or antenna circuit on the module's antenna connector. The antenna detection state is reported to the application through the ANT_DET output signal, and may also be queried by the ATS97 command.

The detection circuit senses DC resistance to ground on the module's antenna connector.

A DC resistance below 100K Ω (\pm 5%) is defined as a valid antenna connection, and the ANT_DET output signal is set high.

A DC resistance above 100K Ω (\pm 5%) is defined as an antenna disconnection, and the ANT_DET output is set low.

4.10.4 GPRS Detection

The GPRS output signal indicates the network GPRS connection status. When the module is connected to a GPRS network, this signal is enabled. When the module is not connected to the GPRS network this signal is disabled.

4.10.5 Transmission Indicator

The TXEN_N output signal indicates when the module is transmitting over the GSM network. This signal follows the module's GSM transmit bursts. This signal is set low during a transmit burst, and set high when no transmission is in progress.

4.11 General Purpose I/O

The module incorporates 8 general purpose IO signals for the user application. Each GPIO signal may be configured and controlled by AT command. These signals may be used to control or set external application circuits, or to receive indications from the external application.

4.12 Antenna Interface

The module's antenna connector is the RF interface to the GSM network.

The antenna interface is terminated by an MMCX connector type, which is 50 Ω impedance matched at the relevant GSM frequencies.

The antenna or antenna application must be installed properly to achieve best performance.

4.13 Charger Model

The charger model module includes a Battery Charger circuit with the following Specifications:

- The Charger circuit supports a battery type of 3.7V Lithium-Ion, with a battery capacity of 500-1000mA/H, typical capacity 850mA/H.
- The Battery will be external to the module and connected through the interface 70 pin connector.

- The Battery charger includes a voltage and current limit circuit.
- Battery charger Temp. Sense: Pin number 45 in the 70 Pin Connector
- Battery Pins: VCC, GND (5, 6, 7, 8 and 1,2,3,4 respectively in 70 pin Connector)
- Charger Pins: Pin Vbus Pin 10 and Ignition Pin 51
- Charger Input Voltage: Min 4.75V, Max 5.8V
- Battery Charge Current: Maximum 500 mA
- The following battery types are not supported and can Not be used: Ni-Cd, Ni-MH and PB.
- The Battery and Battery Charger to be used for reference in the module Charger design is defined as following:
- AC Charger Motorola Part Number: SPN5188B - $V_{out}=5.0V\pm 0.25V_{550mA_0\sim 40C}$
- Battery Motorola Part Number : SNN5771A - LI-ION/850mAH/3.7V

4.14 Interface Connector Pinout

Pin Number	G24-L STD	G24-L STD+Charger
1	GND	GND
2	GND	GND
3	GND	GND
4	GND	GND
5	VCC	VCC
6	VCC	VCC
7	VCC	VCC
8	VCC	VCC
9	RTS	RTS
10	USB_VBUS	VCHG/USB_VBUS
11	RXD	RXD
12	USB_DP	USB_DP
13	DSR	DSR
14	USB_DN	USB_DN
15	CTS	CTS
16	WKUPI_N	WKUPI_N
17	DCD	DCD
18	PCM_DIN	PCM_DIN
19	DTR	DTR
20	PCM_DOUT	PCM_DOUT
21	TXD	TXD
22	PCM_CLK	PCM_CLK
23	RI	RI
24	PCM_FS	PCM_FS
25	RESET_N	RESET_N
26	WKUPO_N	WKUPO_N
27	VREF	VREF
28	GPIO1	GPIO1
29	NC	NC
30	GPIO2	GPIO2
31	NC	NC

32	GPIO3	GPIO3
33	NC	NC
34	GPIO4	GPIO4
35	NC	NC
36	GPIO5	GPIO5
37	ADC1	ADC1
38	GPIO6	GPIO6
39	TXEN_N	TXEN_N
40	GPIO7	GPIO7
41	ANT_DET	ANT_DET
42	GPIO8	GPIO8
43	ADC2	ADC2
44	SIM_RST_N	SIM_RST_N
45	NC	NC
46	SIM_CLK	SIM_CLK
47	ADC3	Bat_Temp
48	SIM_VCC	SIM_VCC
49	GPRS	GPRS
50	SIM_PD_N	SIM_PD_N
51	IGN	USB_VBUS
52	SIM_DIO	SIM_DIO
53	ON_N	ON_N
54	NC	NC
55	HDST_INT_N	HDST_INT_N
56	NC	NC
57	HDST_MIC	HDST_MIC
58	NC	NC
59	AGND	AGND
60	NC	NC
61	MIC	MIC
62	NC	NC
63	ALRT_N	ALRT_N
64	NC	NC
65	ALRT_P	ALRT_P
66	NC	NC
67	SPKR_N	SPKR_N

68	NC	NC
69	SPKR_P	SPKR_P
70	NC	NC

5 Features Specifications

5.1 AT Commands

The module includes the following AT Commands:

AT Commands

AT Command	Description
+CGMI	This command displays manufacturer identification.
+GMI	This command displays manufacturer identification.
+FMI	This command displays manufacturer identification.
+CGMM	This command displays the model identification.
+GMM	This command displays the model identification.
+FMM	This command displays the model identification.
+CGMR	This command displays the revision identification.
+GMR	This command displays the revision identification.
+FMR	This command displays the revision identification.
+CGSN	This command displays the product serial number identification.
+GSN	This command requests the product serial number identification.

+CSCS	This command selects the G24-L character set.
+CIMI	This command displays the International Mobile Subscriber Identity number.
+CFSN	This command displays the factory serial number.
I	This command displays various G24-L information items.
+CNUM	This command displays up to five strings of text information that identify the G24-L.
\$	This command displays a list of all the AT commands supported by the G24-L.
+CLAC	This command displays a list of all the AT commands supported by the G24-L.
D	This command places a voice call on the current network, when issued from an accessory device.
D>	This command places a voice/fax/data call on the current network by dialing directly from the G24-L phone book.
DL	This command places a voice call to the last number dialed.
H	This command hangs up, or terminates a particular call.
A	This command answers an incoming call, placing the G24-L into the appropriate mode, as indicated by the RING message.
+CRC	This command controls whether to present the extended format of the incoming call indication.
RING	This command is unsolicited event and received when an incoming call (voice, data or fax) is indicated by the cellular network.
+CRING	This command is unsolicited event that indicates the type of incoming call.
+CLIP	This command controls the Calling Line Identity (CLI) presentation to the terminal when there is an incoming call.
+CCWA	This command controls the Call Waiting supplementary service, including settings and querying of the network by the G24-L.

+CHLD	This command controls the Call Hold and Multiparty Conversation supplementary services.
+CCFC	This command controls the call-forwarding supplementary service.
+CLIR	This command enables/disables the sending of caller ID information to the called party, for an outgoing call.
+CBST	This command handles the selection of the bearer service and the connection element to be used when data calls are originated.
O	This command returns a phone to the Online Data mode and issues a CONNECT or CONNECT <text> result code.
+CHUP	This command causes the G24-L to hang up the current GSM call.
+CSNS	This command handles the selection of the bearer or teleservice to be used when a mobile terminated single numbering scheme call is established.
+MDC	This command enables you to select the desired messages to be displayed upon connection of a voice call with a remote party.
+CTFR1	This command terminates an incoming call and diverts the caller to the number previously defined in CCFC, or to a voice mail if one exists for the subscriber.
+MCST	This command displays the current state of the call processing, and also enables/disables the unsolicited indication of any change in the call processing state.
+MFIC	This command instructs the G24-L to query or set Filtering Incoming Calls parameters.
+MVC	This command is used to choose and configure the priority order of the supported voice codecs (vocoders)
+CPAS	This command displays the current activity status of the G24-L, for example, call in progress, or ringing.
+CLCC	This command displays a list of all current G24-L calls and their statuses, and also enables/disables the unsolicited indication of the call list.
+CAOC	This command displays information about the cost of calls.

+CACM	This command resets the Advice of Charge accumulated call meter value in the SIM file, EFACM.
+CMM	This command sets the Advice of Charge accumulated call meter maximum value in the SIM file, EFACMmax.
+CPUC	This command sets the parameters of the Advice of Charge-related price per unit and currency table found in the SIM file, EFPUCT.
+CR	This command controls whether or not the extended format of an outgoing call is displayed or not.
+CSSN	This command handles the enabling and disabling of supplementary service-related, network-initiated, notifications.
+CUSD	This command allows control of Unstructured Supplementary Service Data (USSD), according to GSM 02.90.
+COLP	This command refers to the GSM supplementary service COLP, Connected Line Identification Presentation, which enables a calling subscriber to get the connected line identity (COL) of the called party after setting up a mobile-originated call.
+CPBS	This command handles the selection of the memory to be used for reading and writing entries in G24-L phone books memory. (When there is separate storage on the SIM and internal G24-L memory)
+CPBR	This command recalls phone book entries from a specific entry number, or from a range of entries.
+MCSN	This command sets EFmsisdn in the SIM.
+MDSI	This command enables unsolicited reporting of indications of SIM deactivation and invalidation.
+MFS	This command is used to determine how long the G24-L waits before attempting to re-register after a registration attempt has failed and the G24-L is not registered.
+MCI	Motorola Cell Information
+CPBF	This command searches the currently active phone book for a particular entry, by name.
+CPBW	This command stores a new entry in the phone book, or deletes an existing entry from the phone book.

+CSVM	This command handles the selection of the number to the voice mail server.
+CCLK	This command reads/sets the G24-L's current date and time settings.
+CSMS	This command handles the selection of the SMS message service type.
+CPMS	This command handles the selection of the preferred storage area for messages.
+CMGF	This command handles the selection of message formats.
+CSCA	This command handles the selection of the SCA and the TOSCA.
+CSMP	This command sets the Text Mode parameters.
+CSDH	This command shows the Text Mode parameters.
+CNMI	This command sends an unsolicited indication when a new SMS message is received by the G24-L.
+CNMA	This command acknowledges the receipt of a +CMT response.
+CMTI	This unsolicited message, including the SMS message index, is sent upon the arrival of an SMS message.
+CMGL	This command displays a list of SMS messages stored in the G24-L memory.
+MMGL	This command displays a list of SMS messages stored in the G24-L memory.
+CMGR	This command reads selected SMS messages from the G24-L memory.
+MMGR	This command reads selected SMS messages from the G24-L memory.
+MMAR	This command changes the status of an SMS message in the G24-L memory from "REC UNREAD" to "REC READ".
+CMSS	This command selects and sends pre-stored messages from the message storage.

+CMGW	This command writes and saves messages in the G24-L memory.
+CMGD	This command deletes messages from the G24-L memory.
+CGSMS	This command handles the selection of the service or service preference used by the G24-L to send mobile-originated SMS messages.
+CMGS	This command sends an SM from the G24-L to the network.
+CSCB	This command handles the selection of cell broadcast message types and data coding schemes received by the G24-L.
+CMT	This command is unsolicited message that forwards the SMS upon its arrival.
+CBM	This command is unsolicited message that forwards the SMS upon its arrival.
+CDSI	Unsolicited Response (New SMS-STATUS-REPORT Indication)
+CDS	Unsolicited Response (New SMS-STATUS-REPORT Receipt)
+MCSAT	This command enables/disables/exercises SMS alert tone for an arriving SMS.
+CSQ	This command displays the signal strength received by the G24-L.
+CRLP	This command displays the Radio Link Protocol parameters.
+CREG	This command enables/disables the network status registration unsolicited result code.
+CGREG	This command enables/disables the GPRS network status registration unsolicited result code.
+COPS	This command enables accessing the network registration information, as well as select and register the GSM network operator.
+CPOL	This command is used to edit the list of preferred operators located in the SIM card.

+CBC	This command queries the battery charger connection.
+CBAUD	This command sets the baud rate.
+IPR	This command is responsible for setting and saving the request baud rate.
+MTDTR	This command checks and displays the physical current status of the DTR pin of the RS232.
+MTCTS	This command sets the CTS pin of the RS232 to not active (high), waits one second and then sets the CTS to active (low).
&K	This command configures the RTS/CTS flow control.
&C	This command determines how the state of the DCD line relates to the detection of the received line signal from the distant end.
&D	This command determines how the G24-L responds when the DTR (Data Terminal Ready) status is changed from ON to OFF during the online data state.
+MCWAKE	This command displays reports on the status of the GPRS/GSM coverage.
+MGGIND	This command configures the service indicator on pin 49 of the 70 pin connector to be GPRS or GSM.
+CFUN	This command selects the level of functionality. Level "full functionality" is where the highest level of power is drawn. "Minimum functionality" is where minimum power is drawn. This command also can disable phone both transmit and receive RF circuits.
+ICF	This command determines the local serial port start/stop (asynchronous) character framing used by the DCE when accepting DTE commands and transmitting information text and result codes.
S97	This command indicates whether an antenna is physically connected to the G24-L RF connector.
+MRST	This command enables customer software to perform a hard reset to the G24-L unit.
READY	This command is unsolicited notification that indicates UART is ready.

+MIOC	This command defines the G24-L 8 GPIO pins data value.
+MIOD	This command defines the G24-L 8 GPIO pins configuration.
+MMAD	This command reads and monitors digital value from a specified ADC.
+MPCMC (TBD)	This command defines whether the PCM clock is generated continuously or not, when module is in digital audio mode.
+CRTT	This command plays one cycle of a ring tone, stops the cycle in the middle, and sets the ring tone to be used.
+VTD	This command handles the selection of tone duration.
+VTS	This command transmits a string of DTMF tones when a voice call is active.
+CALM	This command handles the selection of the G24-L's alert sound mode.
+MMICG	This command handles the selection of microphone gain values.
+MADIGITAL	This command switches between analog and digital audio modes.
S94	This S-parameter represents the Boolean status, On/Off, of the sidetone feature.
S96	This S-parameter represents the Boolean status, On/Off, of the echo cancelling feature in the handsfree.
+CRSL	This command handles the selection of the incoming call ringer and alert tone (SMS) sound level on the alert speaker of the G24-L.
+CLVL	This command sets the volume of the internal loudspeaker (which also affects the key feedback tone) of the G24-L.
+CMUT	This command mutes/unmutes the currently active microphone path by overriding the current mute state.
+MAPATH	This command sets/requests the active input accessory, and the output accessory for each feature.

+MAVOL	This command determines a volume setting for a particular feature in a particular accessory.
+MAFEAT	This command controls the various algorithm features, such as sidetone, echo cancel and noise suppress.
+MAMUT	This command controls the muting/unmuting of all input paths (MIC, HDST_MIC, DIGITAL_RX).
A/	This command repeats the last command entered on the terminal.
AT	This command checks the AT communication and only returns OK.
+CPIN	This command is only relevant for phones that use SIM cards. It unlocks the SIM card when the proper SIM PIN is provided, and unblocks the SIM card when the proper SIM PUK is provided.
+EPIN	This command is only relevant for phones that use SIM cards. It verifies the PIN2 indicator.
+TPIN	This command queries the number of remaining SIM PIN/PUK entering attempts.
+CPWD	This command sets a new password for the facility lock.
+CLCK	This command locks, unlocks or interrogates a G24-L or a network facility <fac>.
+EMPC	This command unlocks or resets the first PLMN of the inserted SIM.
V	This command determines the response format of the data adapter and the contents of the header and trailer transmitted with the result codes and information responses.
Q	This command determines whether to output/suppress the result codes.
E	This command defines whether the G24-L echoes the characters received from the user, (whether input characters are echoed to output).
X	This command defines the data adaptor response set, and the CONNECT result code format.

Sn	This command reads/writes values of the S-registers, and includes registers 1-49, 94, 96 (Audio) and 102 (Sleep mode).
\S	This command displays the status of selected commands and S-registers.
\G	This command sets the use of the software flow control.
\J	This command adjusts the terminal auto rate.
\N	This command displays the type of link.
?	This command displays the most recently updated value stored in the S-register.
&F	This command restores the factory default configuration profile.
Z	This command resets the default configuration.
S24	This S-parameter activates/disables the Sleep mode. If the parameter value is greater than 0, it represent the number of seconds till the G24-L enters sleep mode.
S102	This S-register sets the value of the delay before sending the data to the terminal.
S100	Set Minimum Time for Terminal to Fall into Sleep Mode
+MSCTS	This command defines the behavior of the CTS line when the G24-L is in Sleep mode.
+CMEE	This command enables/disables the use of result code +CME ERROR: <err> as an indication of an error relating to the functionality of the G24-L.
+CEER	This command returns an extended error report containing one or more lines of information text, determined by the manufacturer, providing the reasons for the call-clearing errors.
+CRSM	This command provides limited access to the Elementary Files on the SIM.

&V	This command displays the current active configuration and stored user profiles.
&W	This command stores the user profile.
&Y	This command displays the default user profile.
+CKPD (TBD)	This command emulates key presses, or virtual keycodes, as if entered from the G24-L keypad or from a remote handset.
+CMER	This command enables an external accessory to receive key press information from the G24-L's internal keypad.
+CLAN	This command handles the selection of language in the ME.
+CIND	This command is used to query the status of various ME indicators.
+MUPB	This command causes the G24-L to send an event when a phone book entry is accessed or modified by the user.
+CDEV (TBD)	This command is unsolicited indication regarding display changes that is sent to the DTE when the <disp> parameter of the +CMER command is set to 1.
+CIEV	This command is unsolicited indication regarding various phone indications that is sent to the DTE when the <ind> parameter of the +CMER command is set to 1.
+CGCLASS	This command sets the GPRS mobile station class.
+CGDCONT	This command specifies the PDP (Packet Data Protocol) context.
+CGQMIN	This command sets the minimum acceptable quality of service profile.
+CGQREQ	This command displays the requested quality of service profile.
+CGACT	This command activates/deactivates the PDP Context.
+CGATT	This command attaches the G24-L to the GPRS network.

+CGDSCONT (TBD)	This command defines Secondary PDP Context
+CGTFT (TBD)	This command is Traffic Flow Template
+CGCMOD (TBD)	This command is PDP Context Modify
+ CGDATA (TBD)	This command is Enter data state
+ CGAUTO	This command is Automatic response to a network request for PDP context activation
+ CGANS	This command is Manual response to a network request for PDP context activation
+ CGEREP	This command is Packet Domain event reporting
+ CGPADDR	This command Shows PDP address
+MGEER	This command is GPRS Extended Error Report
D*99	This command enables the ME to perform the actions necessary for establishing communication between the terminal and the external PDN.
+CGPRS	This command indicates whether there is GPRS coverage.
+MIPCALL	This command creates a wireless PPP connection with the GGSN, and returns a valid dynamic IP for the G24-L.
+MIPOPEN	This command causes the G24-L module to initialize a new socket and open a connection with a remote side.
+MIPODM	This command causes the G24-L module to initialize a new socket in Online Data Mode and open a connection with a remote side.

+MIPCLOSE	This command causes the G24-L module to free the socket accumulating buffer and disconnect the G24-L from a remote side.
+MIPSETS	This command causes the G24-L to set a watermark in the accumulating buffer. When the watermark is reached, data is pushed from the accumulating buffer into the protocol stack.
+MIPSEND	This command causes the G24-L to transmit the data that the terminal provides, using an existing protocol stack.
+MIPPUSH	This command causes the G24-L module to push the data accumulated in its accumulating buffers into the protocol stack.
+MIPFLUSH	This command causes the G24-L module to flush (delete) data accumulated in its accumulating buffers.
+MIPRUDP	This command is unsolicited event that is sent to the terminal when data is received from the UDP protocol stack.
+MIPRTCP	This command is unsolicited event that is sent to the terminal when data is received from the TCP protocol stack.
+MIPSTAT	This command is unsolicited event that is sent to the terminal indicating a change in link status.
+MIPDATA	This command is unsolicited event that is sent to the terminal indicating a data comes from Network when G24-L is in pseudo-command mode.
+MIPXOFF	This command is unsolicited event that is sent to the terminal to stop sending data.
+MIPXON	This command is unsolicited event that is sent to the terminal when the G24-L has free memory in the accumulating buffer.
+MIPCONF	Configure Internal TCP/IP stack
+MPING	This command will allow verifying IP connectivity to another remote machine (computer) by sending one or more Internet Control Message Protocol (ICMP) Echo Request messages.
+MPINGSTAT	This command is the unsolicited response that the G24-L sends to the terminal to inform of ping execution status update and provides summary statistics of ping request when ping request execution is completed.

+MSDNS	This command set/read DNS IP address for each socket.
+FCLASS	This command places the terminal in particular mode of operation (data, fax, voice).
+FTS	This command causes the G24-L to stop any transmission.
+FRS	This command causes the G24-L to listen and to report back an OK result code when the line has been silent for the specified amount of time.
+FTM	This command causes the G24-L to transmit data.
+FRM	This command causes the G24-L to enter the receive mode.
+FTH	This command causes the G24-L to transmit data framed in the HDLC protocol.
+FRH	This command causes the G24-L to receive HDLC framed data and deliver the next received frame to the terminal.
+IFC	This command controls the operation of the local flow control between the terminal and the G24-L.
+FPR	This command sets the request baud rate.

The following AT Commands are defined for backward compatibility only, and has no effect.

+CBAND	This command is supported for backward compatibility only, and has no effect.
%C	This command is supported for backward compatibility only, and has no effect.
&G	This command is supported for backward compatibility only, and has no effect.
&J	This command is supported for backward compatibility only, and has no effect.
&L	This command is supported for backward compatibility only, and has no effect.
&M	This command is supported for backward compatibility only, and has no effect.
&P	This command is supported for backward compatibility only, and has no effect.
&Q	This command is supported for backward compatibility only, and has no effect.
&R	This command is supported for backward compatibility only, and has no effect.
&S	This command is supported for backward compatibility only, and has no effect.
&T	This command is supported for backward compatibility only, and has no effect.
\B	This command is supported for backward compatibility only, and has no effect.
\A	This command is supported for backward compatibility only, and has no effect.
\K	This command is supported for backward compatibility only, and has no effect.

F	This command is supported for backward compatibility only, and has no effect.
L	This command is supported for backward compatibility only, and has no effect.
M	This command is supported for backward compatibility only, and has no effect.
N	This command is supported for backward compatibility only, and has no effect.
P	This command is supported for backward compatibility only, and has no effect.
T	This command is supported for backward compatibility only, and has no effect.
Y	This command is supported for backward compatibility only, and has no effect.
+FAR	This command is supported for backward compatibility only, and has no effect.
+FCL	This command is supported for backward compatibility only, and has no effect.
+FDD	This command is supported for backward compatibility only, and has no effect.
+FIT	This command is supported for backward compatibility only, and has no effect.

5.2 Feature List

The module includes the following features and AT Commands:

Modem ID

+CGMI, +GMI, +FMI, Request Manufacturer ID
+CGMM, +GMM, +FMM, Request Model ID
+CGMR, +GMR, +FMR, Request Revision
+CGSN, +GSN, Request Product Serial Number Identification
+CSCS, Select Terminal Character Set
+CIMI, Request IMSI
+CFSN, Read Factory Serial Number
I, Request Identification Information
+CNUM, Request MSISDN(s)
\$, List of All Available AT Commands
+CLAC, List of All Available AT Commands

Call Control

Managing a CSD (Data) Call
The character '+'
Call Control AT Commands
D, Dial Command
D>, Direct Dialing from Phone Books
DL, Dial Last Number
H, Hang-up Call
A, Answer Incoming Call
+CRC, Cellular Result Codes and RING, +CRING - Incoming Call Indication
+CLIP, Calling Line Identification
+CCWA, Call Waiting Command
+CHLD, Call Related Supplementary Services Command
+CCFC, Call Forwarding Number and Conditions
+CLIR, Calling Line Identification Restriction
+CBST, Select Bearer Service Type
O, Return to Online Data State
&Q, Asynchronous Mode
+CHUP, Hang Up Call
+CSNS, Single Numbering Call Scheme
+MDC, Selection of Desired Message to Be Displayed Upon Connection of a Voice Call
+CTFR1, Divert an Incoming Call When User Busy
+MFIC, Filtering Incoming Calls
+MVC, Motorola Vocoders Configuration
Call Status Messages
+CPAS, Phone Activity Status
+CLCC, List Current Calls
+MCST, Call Status Messages
Call Advice of Charge Commands
+CAOC, Advice of Charge

+CACM, Accumulated Call Meter
Accumulated call meter maximum value (similar to CCM; +CAOC, Advice of Charge)
+CAMM, Accumulated Call Meter Maximum
Accumulated call meter maximum value (similar to CCM; +CAOC, Advice of Charge)
+CPUC, Price per Unit and Currency Table
+CR, Service Reporting Control
Supplementary Services
+CSSN, Supplementary Service Notifications
+CUSD, Unstructured Supplementary Service Data
+COLP, Connected Line Identification Presentation

Phone Books and Clock

Directory Access Commands
+CPBS, Select Phone Book Memory
+CPBR, Read Phone Book Entries
+CPBF, Find Phone Book Entries
+CPBW, Write Phone Book Entry
+CSVM, Set Voice Mail Server
+MDSI, Motorola Deactivate SIM Card Indication
+MCSN, Motorola Change Subscriber Number
System Date and Time Access Commands
+CCLK, Read/Set System Date and Time

SMS

SMS Commands
+CSMS, Select Message Service.
+CPMS, Preferred Message Storage
+CMGF, Message Format
+CSCA, Service Center Address
+CSMP, Set Text Mode Parameters
+CSDH, Show Text Mode Parameters
+CNMI, New Message Indications to Terminal
+CNMA, New Message Acknowledgment
+CMTI, Unsolicited Response (SMS-DELIVER Receipt Indication)
+CMT, Unsolicited Response (New SMS-DELIVER Receipt)
+CBM, Unsolicited Response (New CB Message Receipt)
+CDSI, Unsolicited Response (New SMS-STATUS-REPORT Indication)
+CDS, Unsolicited Response (New SMS-STATUS-REPORT Receipt)
+CMGL, +MMGL, List Messages
+CMGR, +MMGR, Read Message
+MMAR, Motorola Mark As Read
+CMSS, Send Message From Storage
+CMGW, Write Message to Memory
+CMGD, Delete Message
+CGSMS, Select Service for MO SMS Messages
+CMGS, Send SM to Network
+CSCB, Cell Broadcast Messages
+MCSAT, Motorola Control SMS Alert Tone

Network

Network Commands

- +CSQ, Signal Strength
- +CRLP, Radio Link Protocol
- +CREG, Network Registration Status
- +CGREG, GPRS Network Registration
- +COPS, Operator Selection
- +CPOL, Preferred Operators
- +MFS, Motorola Frequency of Search
- +MCI, Motorola Cell Information

Hardware Information

Hardware Information Commands

- +CBC, Battery Charger Connection TBD
- +CBAUD, Baud Rate Regulation
- +IPR, Local Terminal/G24-L Serial Port Rate
- +MTDTR, DTR Line Test Command
- +MTCTS, CTS Line Test Command
- &K, RTS/CTS Flow Control
- &C, Circuit 109 Behavior
- &D, Circuit 108 Behavior
- +MCWAKE, GPRS Coverage
- +MGGIND, GSM/GPRS Service Indicator
- +CFUN, Shut Down Phone Functionality
- +ICF, DTE-DCE Character Framing
- ATS97, Antenna Diagnostic
- +MRST, Perform Hard Reset
- +MIOC, Motorola I/O Configure
- +MIOD, Motorola I/O Define
- +MMAD, Query and Monitor ADC Value

Audio

Audio Setup

Basic Audio Setup Commands

- +CRSL, Call Ringer Level
- +CLVL, Loudspeaker Volume
- +CMUT, Mute/Unmute Currently Active Microphone Path
- S94, Sidetone Effect
- S96, Echo Canceling

Advanced Audio Setup Commands

- +MAPATH, Audio Path
- +MAVOL, Volume Setting
- +MAMUT, Input Devices Mute
- +MAFEAT, Features Selection

General Audio Commands

- +MADIGITAL, Analog/Digital Audio Switching
- +CALM, Alert Sound Mode
- +MMICG, Microphone Gain Value
- +CRTT, Ring Type Selection
- +VTD, Tone Duration
- +VTS, Command-Specific Tone Duration

Access

Access Control Commands

A/, Repeat Last Command

AT, Check AT Communication

+CPIN, Enter PIN for Unlocking SIM Card or Enter PUK for Unlocking SIM Card

+EPIN, Enter SIM PIN2 to Verify PIN2 Indicator

+TPIN, Query Number of Remaining SIM PIN/PUK Entering Attempts

+CPWD, Change Password

+CLCK, Facility Lock

+EMPC, Unlocking or Locking Subsidy Code

Modem Configuration and Profile**Modem Register Commands**

V, G24-L Response Format

Q, Result Code Suppression

E, Command Echo

X, Result Code Selection and Call Progress Monitoring Control

S, Bit Map Registers

S2

S12

\S, Show the Status of the Commands and S-registers in Effect

\G, Software Control

\J, Terminal Auto Rate

\N, Link Type

+CBAND, Change Radio Band

?, Return the Value of the Last Updated S-register

&F, Set to Factory Defined Configuration

Z, Reset to Default Configuration

Sleep Mode Commands

S24, Set Number of Seconds Delay Before G24-L Enters Sleep Mode

S102, Set Delay Before Sending Data to the Terminal

S100, Set Minimum Time for Terminal to Fall into Sleep Mode

+MSCTS, Enable/Disable CTS During Wakeup Period

Error Handling Commands

+CMEE, Report Mobile Equipment Error

+CEER, Extended Error Report

UI (User Interface)

+CRSM, Restricted SIM Access

&V, View Configuration

&W, Store User Profile

&Y, Default User Profile

(TBD) +CKPD, Keypad Control

+CMER, Mobile Equipment Event Reporting

+CLAN, ME Language

+CIND, Indicator Control

Unsolicited UI Status Messages

(TBD) +CDEV, Change Display Indication

+CIEV, Indicator Event Reporting

+MUPB, Phone Book Event

GPRS

GPRS Functionality**GPRS Commands**

+CGCLASS, GPRS Mobile Station Class
+CGDCONT, Define PDP Context
+CGQMIN, Quality of Service Profile (Min Acceptable)
+CGQREQ, Quality of Service Profile (Requested)
+CGATT, CGPRS Attach or Detach
(TBD)+CGDSCONT, Define Secondary PDP Context
(TBD)+CGTFT, Traffic Flow Template
(TBD)+CGCMOD, PDP Context Modify
(TBD)+CGDATA, Enter data state
+CGAUTO, Automatic response to a network request for PDP context activation
+CGANS, Manual response to a network request for PDP context activation
+CGEREP, Packet Domain event reporting
+CGPADDR, Show PDP address
+MGEER, GPRS Extended Error Report
D*99, Request GPRS Service "D"
+CGPRS, GPRS Coverage
+CGACT, PDP Context Activate or Deactivate

TCP/IP

+MIPCALL, Create a Wireless Link
+MIPOPEN, Open a Socket (UDP or TCP)
+MIPODM, Open a Socket (UDP or TCP) in Online Data Mode
+MIPCLOSE, Close a Socket
+MIPSETS, Set Size for Automatic Push
+MIPSEND, Send Data
+MIPPUSH, Push Data into Protocol Stack
+MIPFLUSH, Flush Data from Buffers
+MIPRUDP, Receive Data from UDP Protocol Stack
+MIPRTCP, Receive Data from TCP Protocol Stack
+MIPSTAT, Status Report
MIPXOFF, Flow Control - Xoff
MIPXON, Flow Control - Xon
MIPCONF - Configure Internal TCP/IP stack
+MPING, Start Ping Execution (ICMP Protocol)
+MPINGSTAT, Status Update for +MPING Execution
+MSDNS, Set DNS IP Address

NOP - Compatible

IGNORED (Compatible Only) Commands

Fax Class 1**Fax Commands**

+FCLASS, Select Mode
+FTS, Transmit Silence
+FRS, Receive Silence
+FTM, Transmit Data
+FRM, Receive Data
+FTH, Transmit DATA with HDLC Frame
+FRH, Receive DATA with HDLC Frame



+IFC, Terminal-G24-L Local Flow Control
+FPR, Fax Serial Port Rate